

MODify Riser 02

MODify™ is a one-of-a-kind Modular Merchandising System that is made up of interchangeable fixtures and accessories that can be easily assembled, disassembled, and rearranged to create a variety of different display configurations. The MODify system incorporates SEG push-fit fabric graphics that enable you to brand, promote and merchandise with ease.

Crafted from durable steel, the MODify Riser 02 is easy to transport and set up. The sturdy construction ensures that your merchandise will remain secure and stable, even when handling heavier items. The optional magnetic graphic offers endless possibilities for branding and messaging on all sides.



We are continually improving and modifying our product range and reserve the right to vary the specifications without prior notice. All dimensions and weights quoted are approximate and we accept no responsibility for variance. E&OE. See Graphic Templates for graphic bleed specifications

features and benefits:

- 47.75"W x 12"H x 23.75"D
- Heavy duty black steel
- Inset laminate wood top comes in white, black, natural, or gray wood grain
- Optional magnetic graphics

dimensions:

Hardware

Assembled unit:

47.75"W x 12"H x 23.75"D
1212.85mm(w) x 304.8mm(h) x 603.25mm(d)

Approximate Weight:
47 lbs / 21.3188 kg

Shipping

Packing case(s):
1 Box

Shipping dimensions:
(52"L x 6"H x 30"D)
1320.8mm(l) x 152.4mm(h) x 762mm(d)

Approximate shipping weight:
64 lbs / 29.0299 kg

Graphics

Graphic material: Dye-sublimated fabric

See graphic templates for graphic sizes.

Refer to related graphic templates for more information Visit:

<https://www.theexhibitorshandbook.com/downloads/download-graphic-templates>
or click here

additional information:

Powder coat color options:



Wood laminate color options:





Tools Required



PHILLIPS SCREW DRIVER
(NOT INCLUDED)

SETUP INSTRUCTIONS

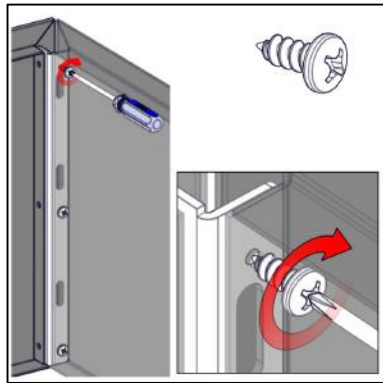

QTY	IMAGE	DESCRIPTION
2		2x1 Panel
2		4x1 Panel
12		1/2" No 10 Metal Screw

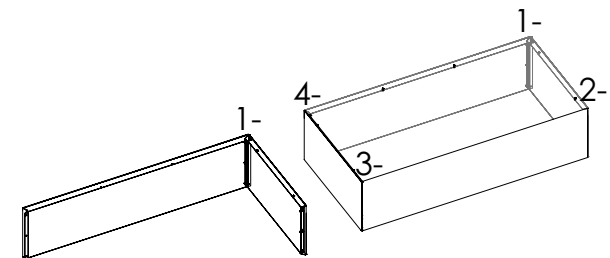
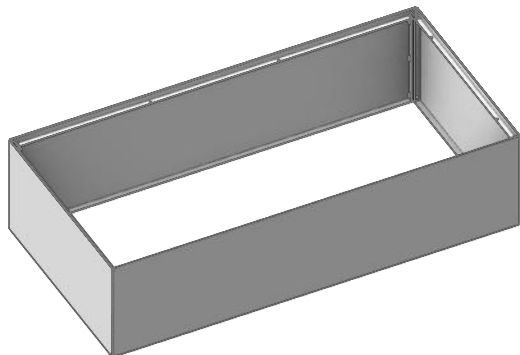
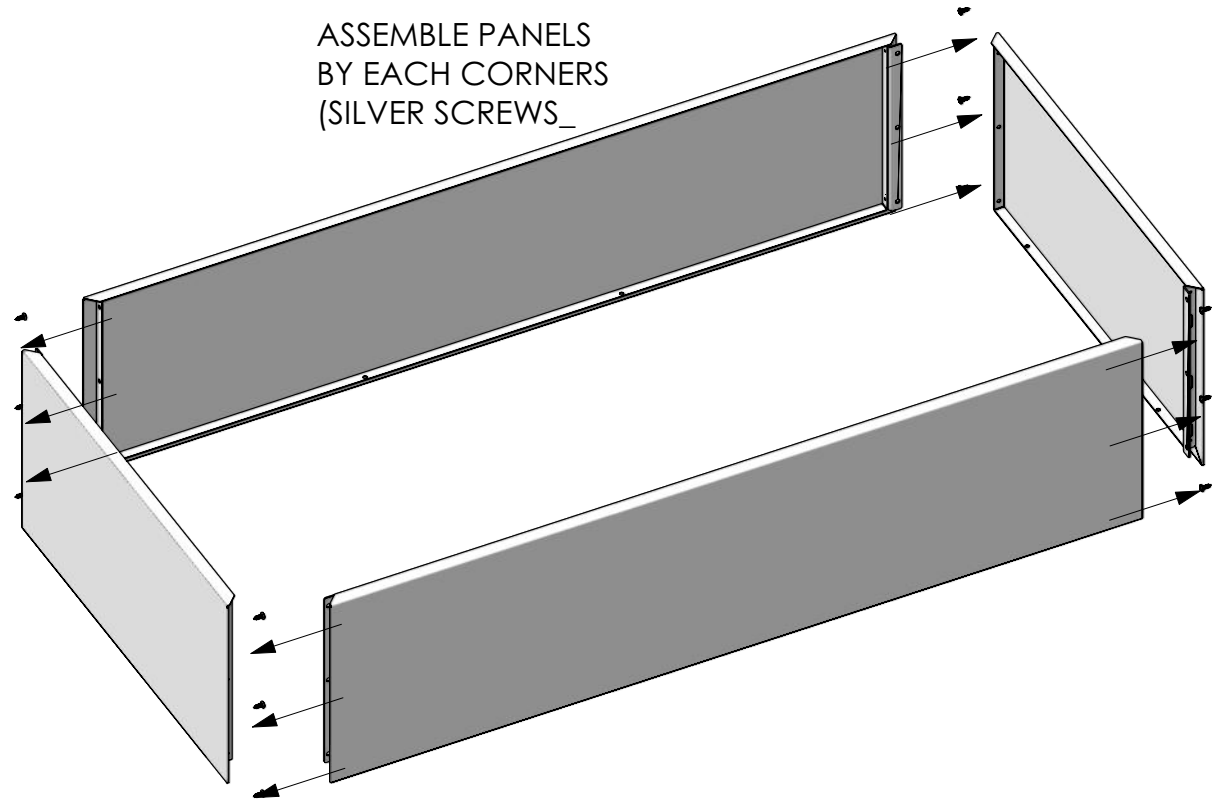

STEP 1

ASSEMBLE PANELS
BY EACH CORNERS
(SILVER SCREWS_



QTY	IMAGE	DESCRIPTION
1		4x2 Top
8		1/2" No 10 Metal Screw(black)



SETUP INSTRUCTIONS

STEP 2

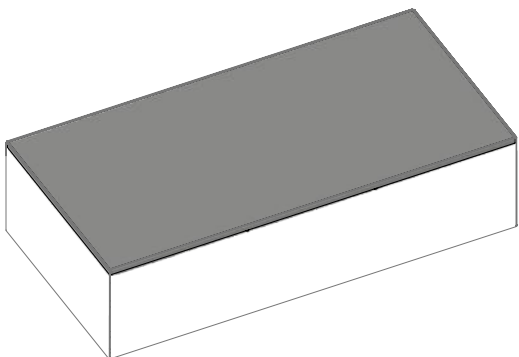
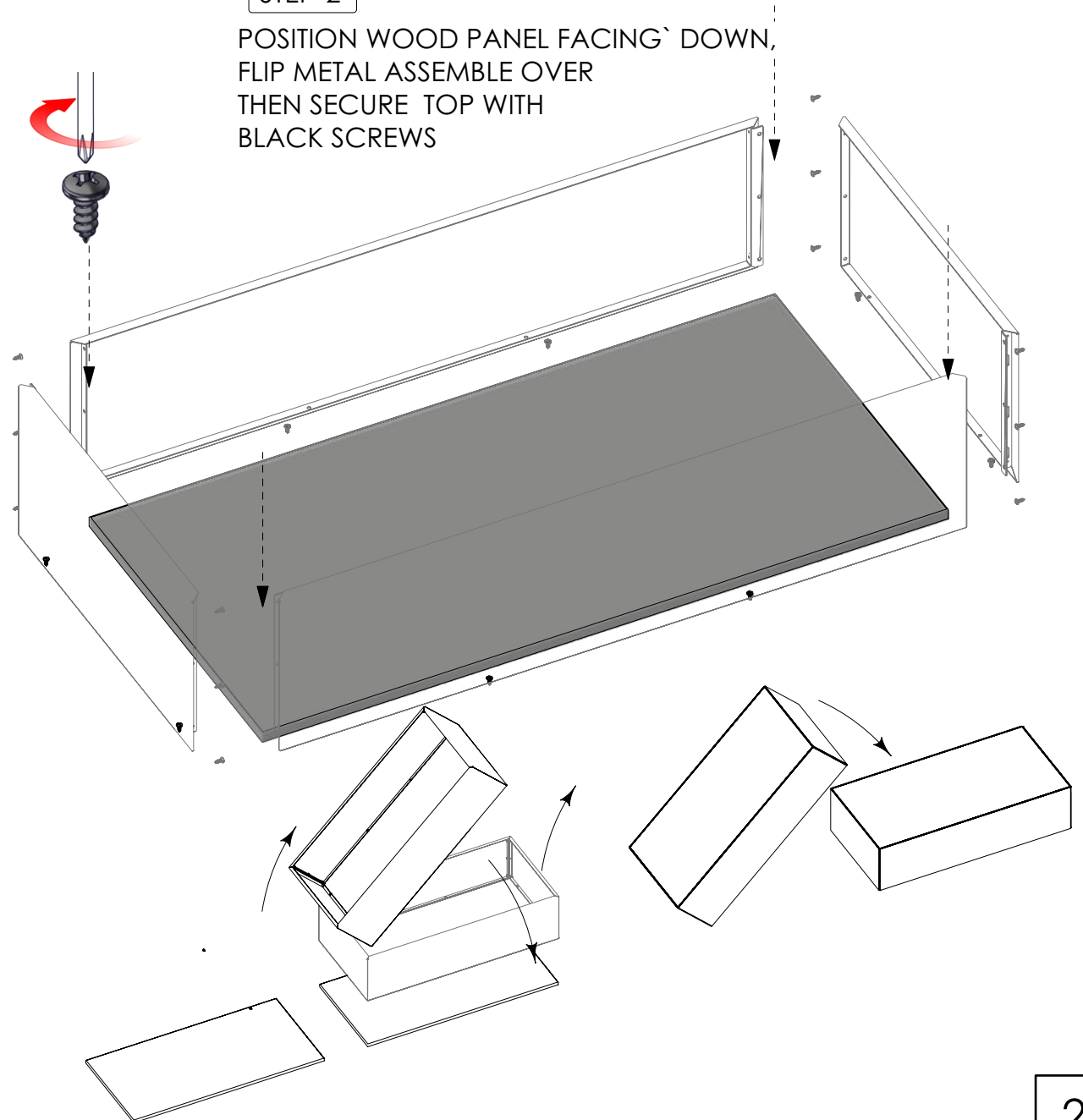
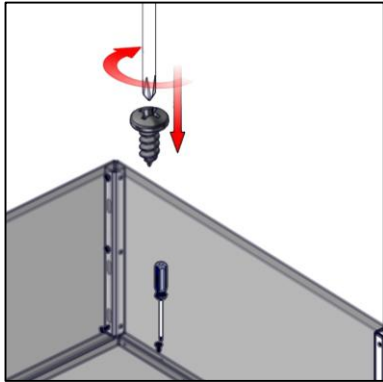
POSITION WOOD PANEL FACING` DOWN,
FLIP METAL ASSEMBLY OVER
THEN SECURE TOP WITH
BLACK SCREWS



SETUP INSTRUCTIONS



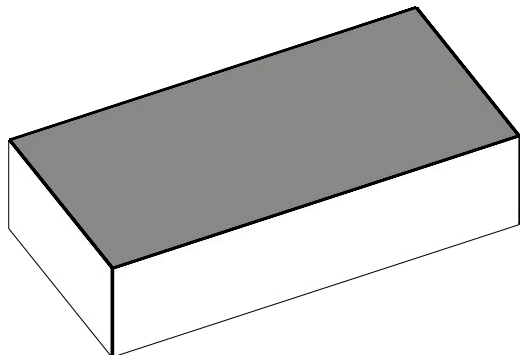
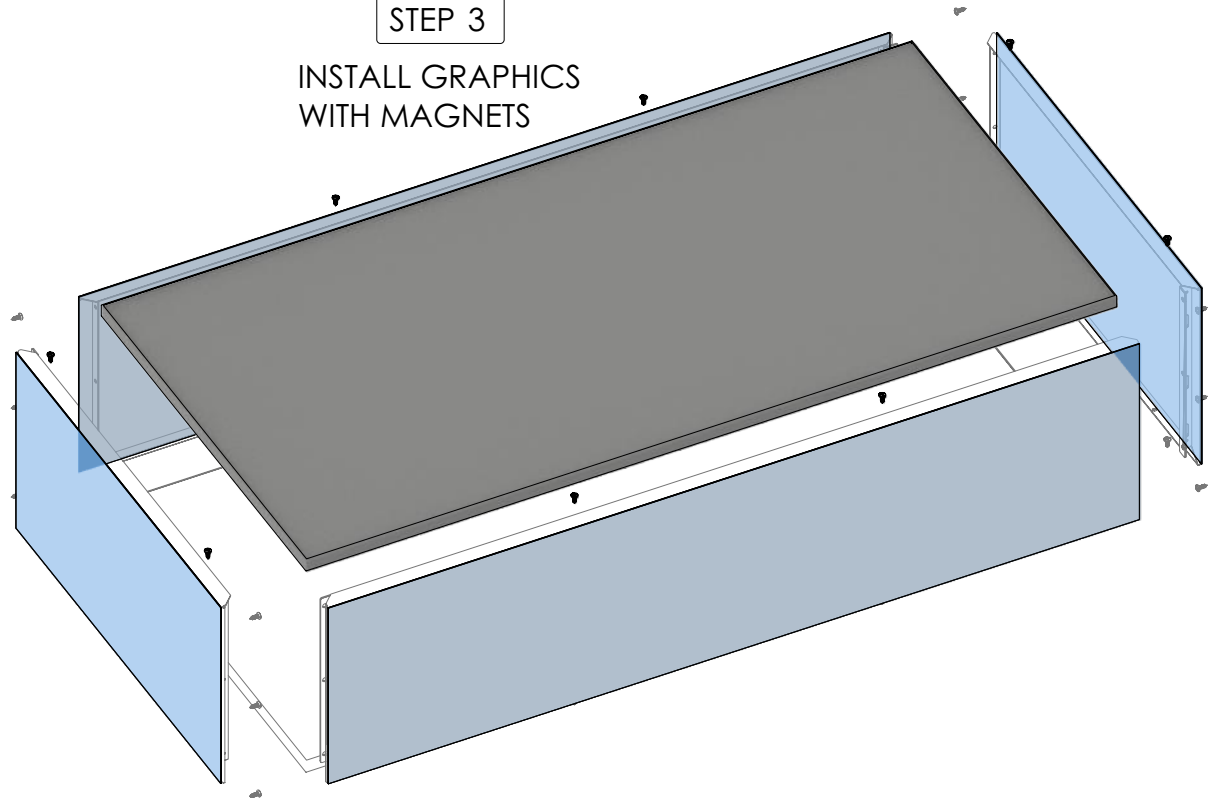
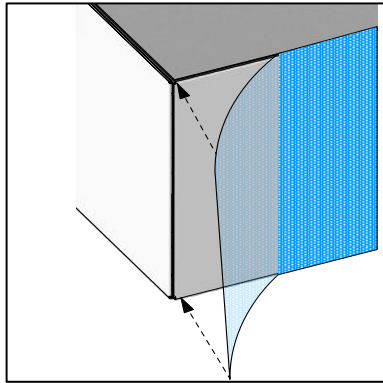

QTY	IMAGE	DESCRIPTION
2		(48.43 w X 12.87 h total size) 47.43 w X 11.87 h finish size, 1mm magnetized 1 sided print.
2		(24.43 w X 12.87 h total size) 23.43 w X 11.87 h finish size, 1mm magnetized 1 sided print.

STEP 3





INSTALL GRAPHICS WITH MAGNETS



Kit Hardware BOM

ITEM	COMPONENTS	QTY	DESCRIPTION
	2x1 Panel	2	2x1 Panel
	4x1 Panel	2	4x1 Panel
	4x2 Top	1	4x2 Top
	SCREW	12	1/2" No 10 Metal Screw
	SCREW	8	1/2" No 10 Metal Screw(black)

Kit Graphics BOM

	MFY-RSR-02-A-G	1	(48.43 w X 12.87 h total size) 47.43 w X 11.87 h finish size, 1mm magnetized 1 sided print.
	MFY-RSR-02-B-G	1	(24.43 w X 12.87 h total size) 23.43 w X 11.87 h finish size, 1mm magnetized 1 sided print.
	MFY-RSR-02-C-G	1	(48.43 w X 12.87 h total size) 47.43 w X 11.87 h finish size, 1mm magnetized 1 sided print.
	MFY-RSR-02-D-G	1	(24.43 w X 12.87 h total size) 23.43 w X 11.87 h finish size, 1mm magnetized 1 sided print.