

MODify Nesting Table 03

MODify™ is a one-of-a-kind Modular Merchandising System that is made up of interchangeable fixtures and accessories that can be easily assembled, disassembled, and rearranged to create a variety of different display configurations. The MODify system incorporates SEG push-fit fabric graphics that enable you to brand, promote and merchandise with ease.

The MODify Nesting Table 03 is a perfect addition to any space. The sturdy metal frame provides excellent support and stability, while the elegant wooden tabletops add a touch of warmth and sophistication to any room. SEG push-fit fabric graphics are fantastic options for each side, and provide a creative way to show branding, messaging and color. MODify Nesting Table 03 slides over Nesting Table 04; the nesting feature makes the tables versatile and the sleek design makes them ideal for any space.



We are continually improving and modifying our product range and reserve the right to vary the specifications without prior notice. All dimensions and weights quoted are approximate and we accept no responsibility for variance. E&OE. See Graphic Templates for graphic bleed specifications

features and benefits:

- 34" W x 36" H x 30" D
- Leg frames available in silver, white, and black
- White, black, natural, or gray wood grain laminate wood tops
- Optional SEG push-fit graphic for each side

dimensions:

Hardware

Assembled unit:

34" W x 36" H x 30" D
863.6mm(w) x 914.4mm(h) x 762mm(d)

Approximate Weight:
55 lbs / 24.9476 kg

Shipping

Packing case(s):
1 Box

Shipping dimensions:
(38" L x 6" H x 36" D)
965.2mm(l) x 152.4mm(h) x 914.4mm(d)

Approximate shipping weight:
66 lbs / 29.9371 kg

Graphics

Graphic material: Dye-sublimated fabric

See graphic templates for graphic sizes.

Refer to related graphic templates for more information Visit:

<https://www.theexhibitorshandbook.com/downloads/download-graphic-templates>
or click here

additional information:

Powder coat color options:



Wood laminate color options:







Tools Required



MULTI HEX KEY
(Included)



PHILLIPS SCREW DRIVER
(Not Included)

QTY	IMAGE	DESCRIPTION
1		RIGHT SUPPORT FRAME WITH LEVELING FEET
1		LEFT SUPPORT FRAME WITH LEVELING FEET
2		750MM LENGTH OF PH2 EXTRUSION-WITH CAM LOCKS BOTH ENDS
1		750MM LENGTH OF PH1 EXTRUSION-WITH CAM LOCKS BOTH ENDS

SETUP INSTRUCTIONS

ASSEMBLE FRAME



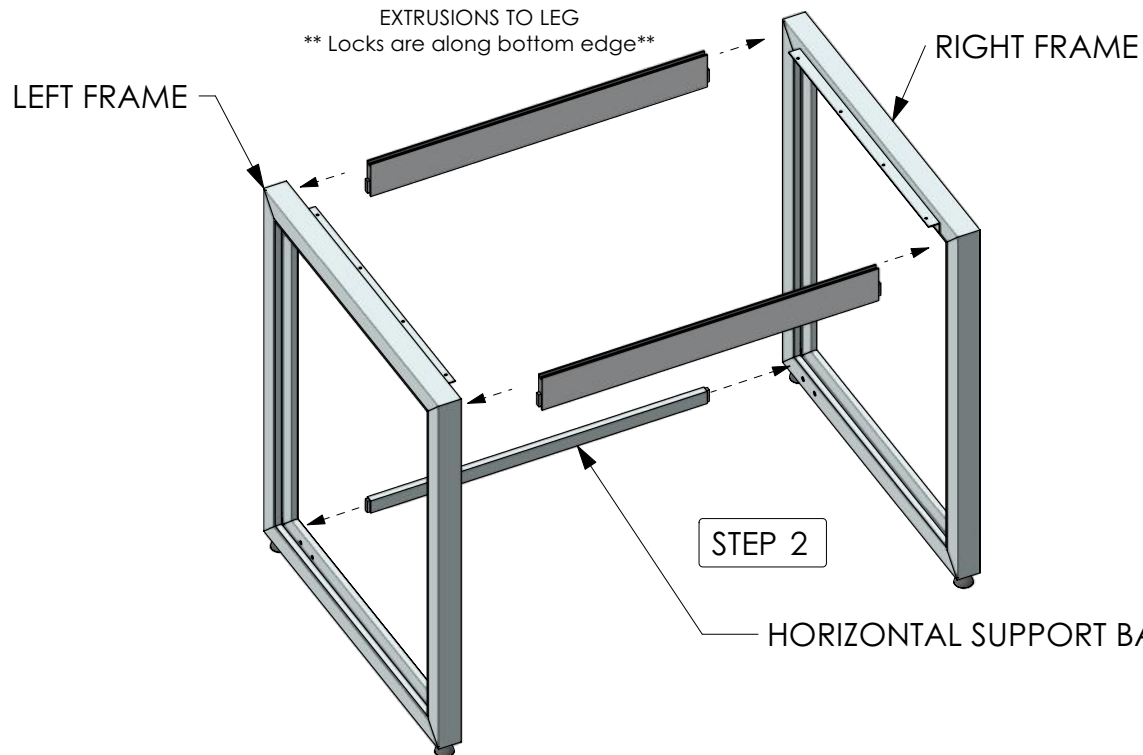

STEP 1

LOCK TOP 2 HORIZONTAL EXTRUSIONS TO LEG
** Locks are along bottom edge**

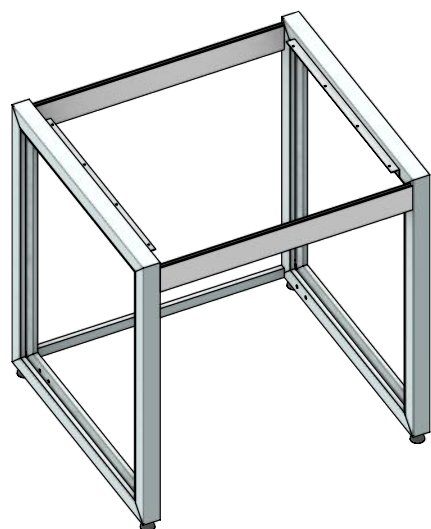

STEP 2



QTY	IMAGE	DESCRIPTION
1		TABLE TOP COUNTER
8		TABLE TOP WOOD SCREW

INSTALL COUNTER TOP

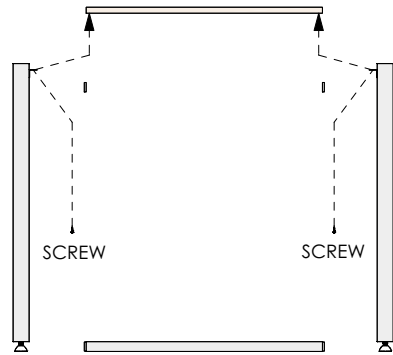

FRONT VIEW

FASTEN COUNTER TOP
TO SIDE FRAMES WITH
WOOD SCREWS (8 REQ'D)
THRU MOUNTED LBRACKETS

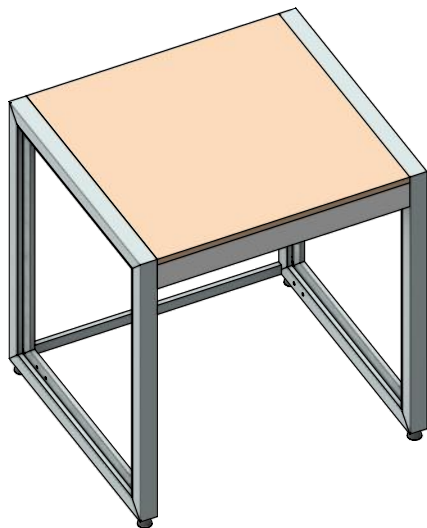
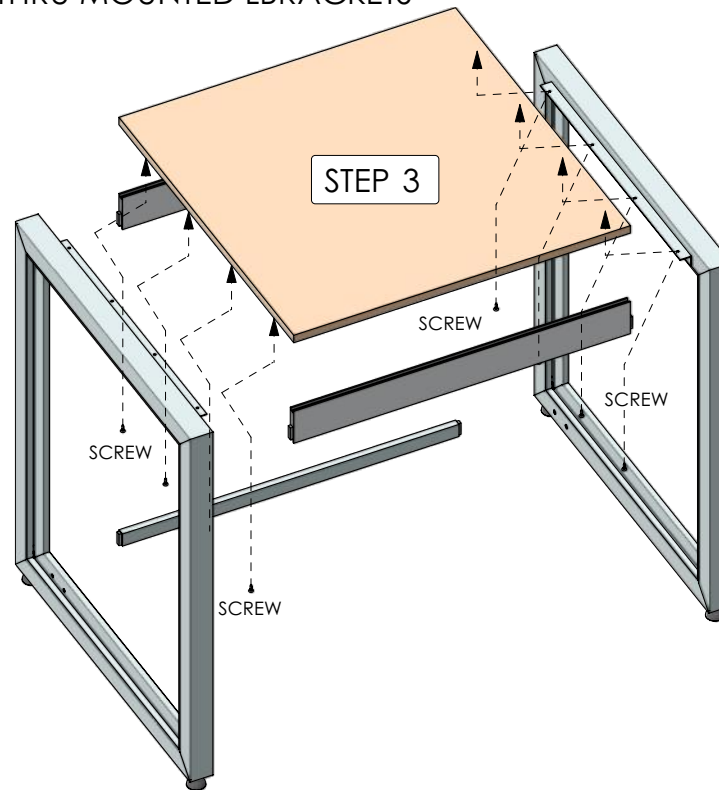

QTY	IMAGE	DESCRIPTION
2		(30.50 w X 35.23 h total size) 26.50 w X 31.23 h finish size, Dye-sub print on Eclipse Blockout Stretch, single sided, sewn with FCE-2 silicone beading around perimeter & pull tab in bottom right corner

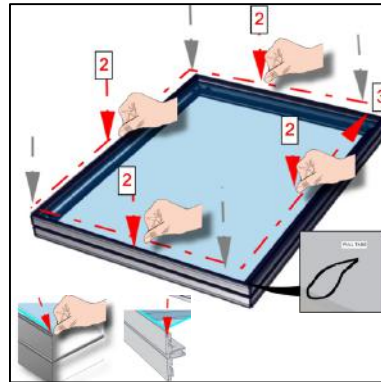





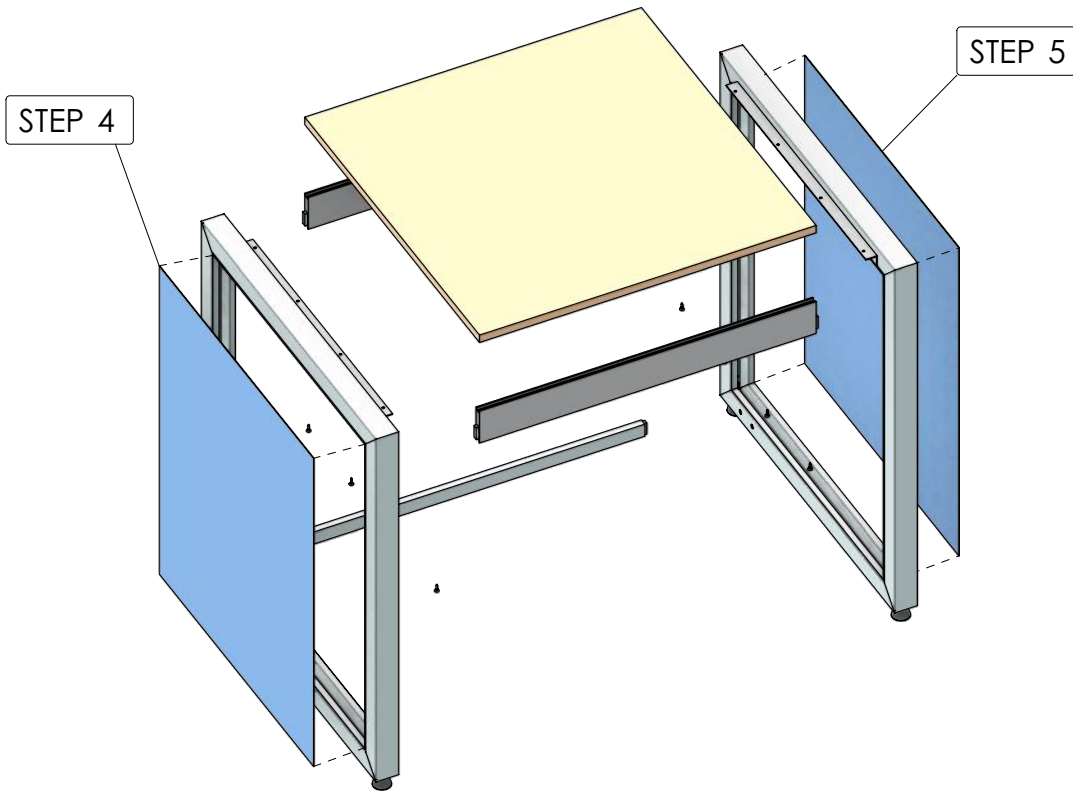
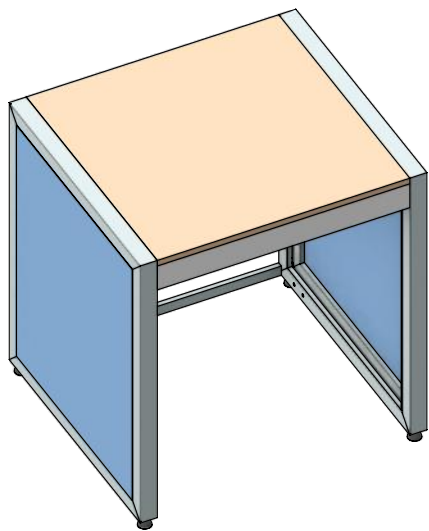

INSTALL GRAPHICS



THEN PRESS ALONG THE PERIMETER EDGE



Kit Hardware BOM

ITEM	COMPONENTS	QTY	DESCRIPTION
	101-750-01-01	1	750MM LENGTH OF PH1 EXTRUSION-WITH CAM LOCKS BOTH ENDS
	102-750-01-01	2	750MM LENGTH OF PH2 EXTRUSION-WITH CAM LOCKS BOTH ENDS
	CT	1	TABLE TOP COUNTER
	LSF	1	LEFT SUPPORT FRAME WITH LEVELING FEET
	RSF	1	RIGHT SUPPORT FRAME WITH LEVELING FEET
	WOOD-SCREW	8	TABLE TOP WOOD SCREW

Kit Graphics BOM

	MFY-TBL-03-A-G	1	(30.50 w X 35.23 h total size) 26.50 w X 31.23 h finish size, Dye-sub print on Eclipse Blockout Stretch, single sided, sewn with FCE-2 silicone beading around perimeter & pull tab in bottom right corner
	MFY-TBL-03-B-G	1	(30.50 w X 35.23 h total size) 26.50 w X 31.23 h finish size, Dye-sub print on Eclipse Blockout Stretch, single sided, sewn with FCE-2 silicone beading around perimeter & pull tab in bottom right corner