

Straight-Leg Counter

LN-CU-07

Dress up your space with sophisticated and functional counters. Counter tops are available in four thermoform finishes – silver, black, mahogany, and natural. Printed graphic panels create the base of the counter. Comes standard with a locking cabinet door. Custom counter top colors are available.



features and benefits:

- Custom appearance
- Easy to assemble
- Table top available in four finishes
- Locking door
- Internal shelf
- Installation tool included
- Aluminum frame construction
- Custom top and graphic colors available
- Legs can turn 90° for a different look
- Lifetime limited hardware warranty against manufacturer defects

dimensions:

Hardware

Assembled Unit:
45.9" w x 40.2" h x 21.2" d
1166mm(w) x 1020mm(h) x 538mm(d)

Approximate weight:
45 lbs / 21 kgs

Shipping

Packing case(s):
1 OCH2

Shipping dimensions:
52" l x 29" h x 15" d
1321mm(l) x 737mm(h) x 381mm(d)

Approximate total shipping weight
(includes case & graphics):
80 lbs / 37 kgs

Graphic

Refer to related graphic template for more information.

Visit exhibitors-handbook.com/graphic-templates

additional information:

Interior Cabinet Dimensions:
22" w x 39" h x 12" d
559mm(w) x 991mm(h) x 305mm(d)

Tabletop Dimensions:
45.9" w x 1.2" h x 21.2" d
1166mm(w) x 31mm(h) x 538mm(d)

Graphic material:
UV - 6mm Sintra

Counter holds max 50 lbs / 23 kgs

Shelf holds max 10 lbs / 6 kgs

When included in a larger kit, a different packaging solution will be listed to accommodate all contents of the kit. Individual packaging no longer provided.

Tabletop Colors:



silver

black

mahogany

natural

We are continually improving and modifying our product range and reserve the right to vary the specifications without prior notice. All dimensions and weights quoted are approximate and we accept no responsibility for variance. E&OE. See Graphic Templates for graphic bleed specifications.

Included In Your Kit

Tools, Components, Connectors, & Extrusions



5MM ALLEN-T x1



PH-280-S-S x4



V-CAB-01-DR x1



V-CAB-01-FR x1



SS1-S x4



V-CU-CT-01 x1



V-CU-CAB-01-S x1



V-LG-05 x1

Graphics



V-CAB-01-GF-FR-01 x1

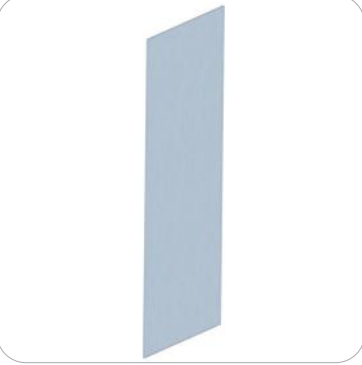

V-CAB-01-GF-SD x2



V-CAB-01-GF-DR x1

Exploded View

LN-CU-07

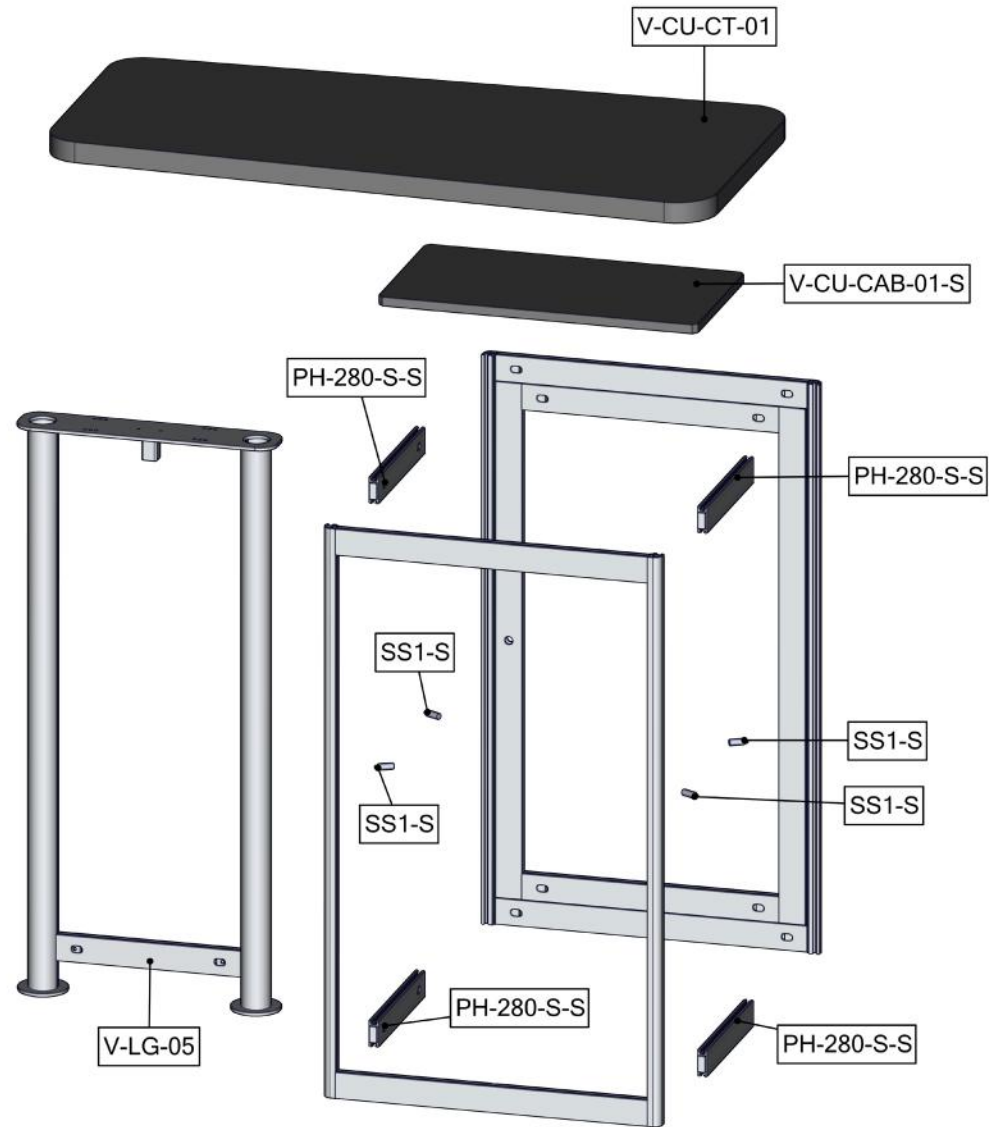

Connection Methods

Connection Method 1: P90R / PH-L



First, with the cam lock disengaged, place the cam lock teeth into the extrusion channel. Second, use the allen key tool to lock it in place. Make half turns clock-wise to engage the cam lock. Do not over tighten the lock buttons.

Connection Method 2: Counter Legs with thumb screw

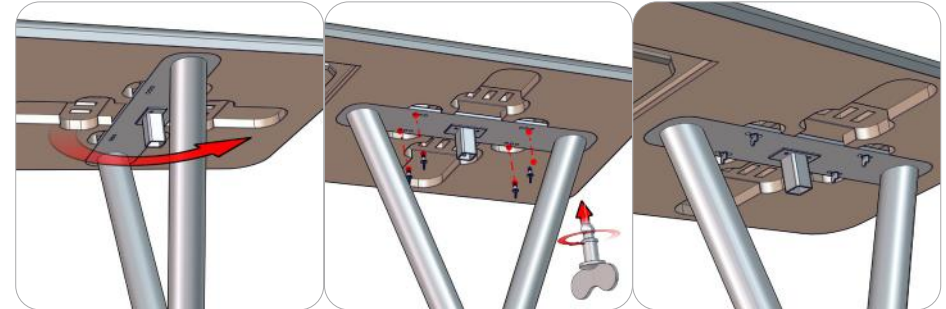

First, choose an orientation for the counter leg to be positioned on the under side of the counter top. With the counter leg in place, use the thumb screws to fasten the top plate of the leg onto the underside of the counter top. Do not over tighten.

Connection Method 3: SS1-1

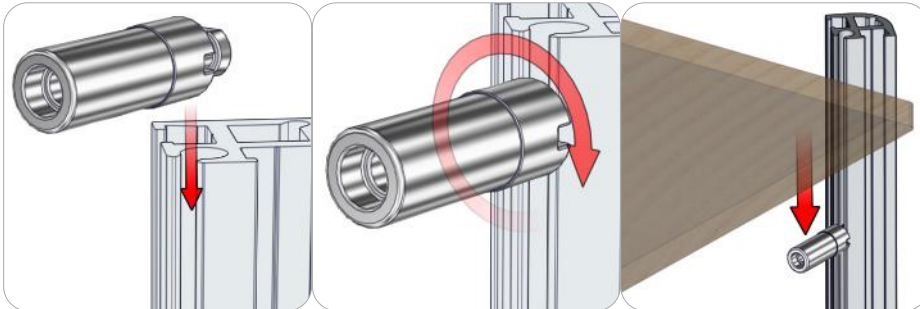

First, take the shelf support and loosen the set screw to about a 1/4 inch gap. Do not remove it. Second, slide the shelf support into the 3mm center channel. Turn the shelf support clock wise to lock it in place. Third, rest the shelf onto the shelf support. Loosen the shelf support to adjust and level.

Kit Assembly

Step by Step

Step 1.

Locate your V-CAB-01-DR and V-CAB-01-FR assemblies. Both frames should have preinstalled graphics. V-CAB-01-DR should also have a locking door, test to ensure it is properly functioning.

Reference Connection Method 1 for more details.

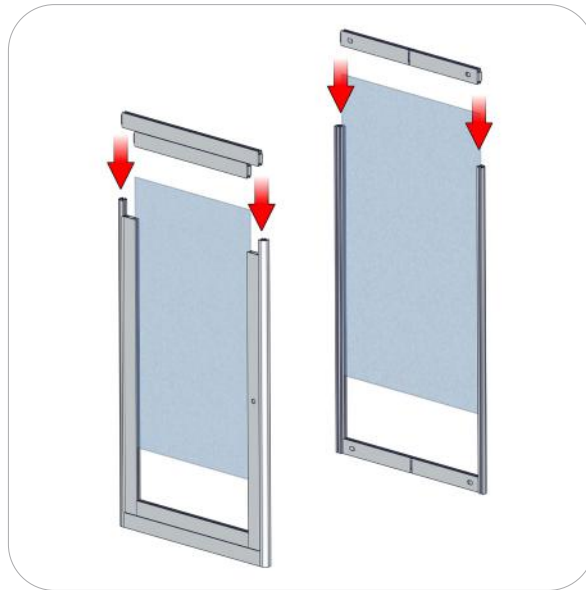
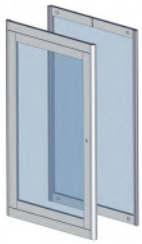

Step 2.

Locate (2) PH-280-S-S extrusions. Lock into place so that the hex bolt heads face inward to the cabinet and the extrusion is flush with the V-CAB-01-DR and V-CAB-01-FR.

Reference Connection Method 1 for more details.

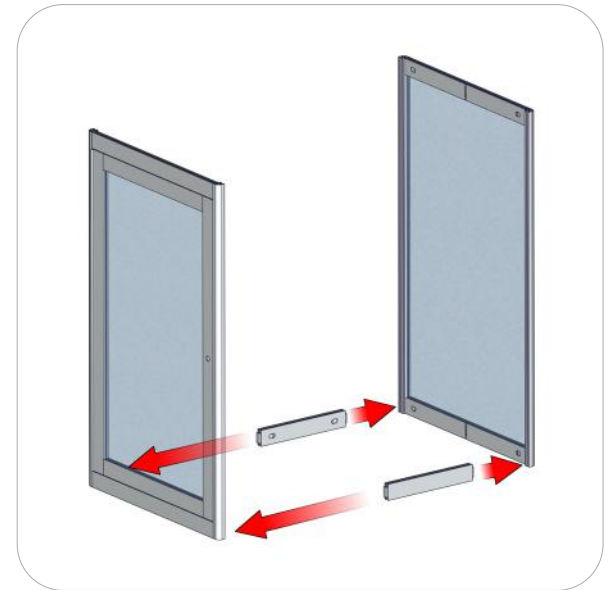

Step 3.

Locate (2) PH-280-S-S extrusions and cabinet side graphic panels. Slide your graphic into the channels of V-CAB-01-FR and V-CAB-01-DR. Next, lock your PH-280-S-S extrusions above the graphics.

Reference Connection Method 1 for more details.

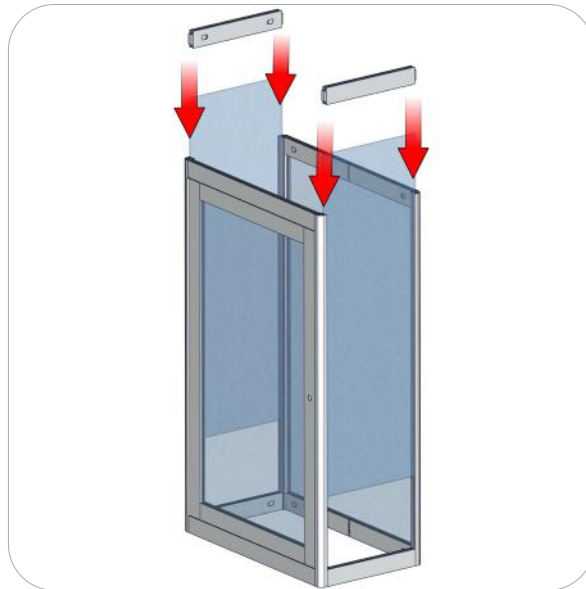

Step 4.

Locate your V-LG-05 and V-CU-CT-01 counter top. Note the imprinted placement templates on the underside of your counter top. Match the V-LG-05 with the counter top in the desired orientation. Lock your V-LG-05 to the counter top with the provided fastening hardware.

Reference Connection Methods 2 & 3 for more details.

