

Charisma SEG/LED Light Box Elevated Stand™ - XLD Series

1. Attach the uprights to the bases using the screws provided.
2. Assemble the frame. See page 2 and 3 for detailed instructions.
3. Attach the frame to the uprights using the puck-screws provided. The frame may be attached at the 12" floor clearance or 24" floor clearance height.
4. Attach the graphics to the frame. See page 4 for detailed instructions.

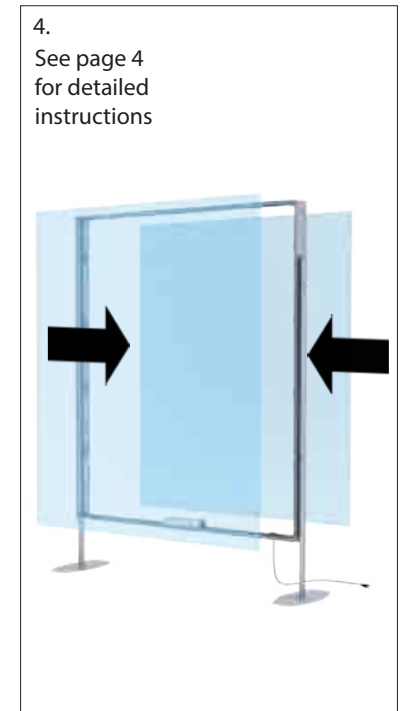
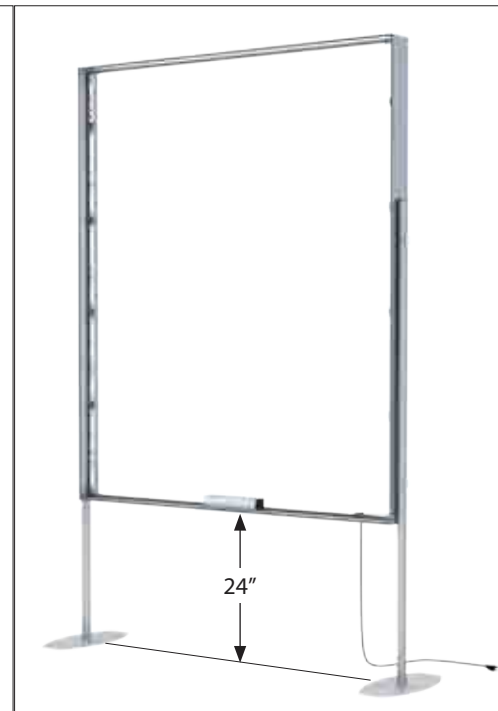
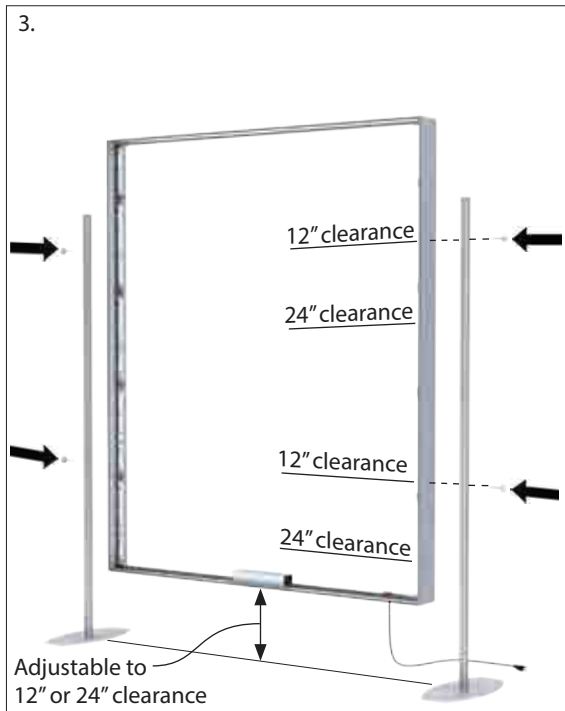
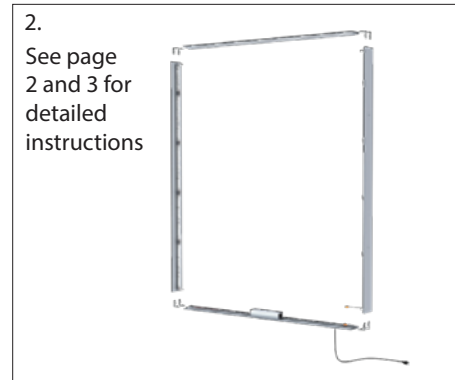
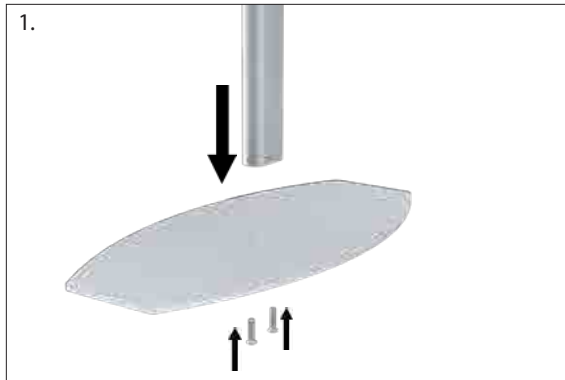

XLD56 shown

Charisma™ SEG Double Sided Light Box - XSD Series

Page 2 - Assemble the Frame

First start by assembling corners. There are three (2) brackets per corner. All extrusion sections are numbered to identify which pieces go together, 1 with 1, 2 with 2, etc.

1. Insert the bent bracket into the extrusion where shown. Firmly screw the brackets into place. Take the mating extrusion piece with matching number. Guide the corner brackets in, then tighten all brackets.
2. Repeat assembly steps for the three remaining corners.
3. For larger boxes, sides may be built in multiple sections. These sections end in a straight cut (NOT a 45° angle). Use the two (2) straight brackets to connect the two adjoining sections. The screws will be tightened from the inside of the frame. Sections can be identified with matching numbers.
4. If provided, place center support bar bracket into frame channel and use the Allen key to expand the bracket inside the channel to secure it in place.

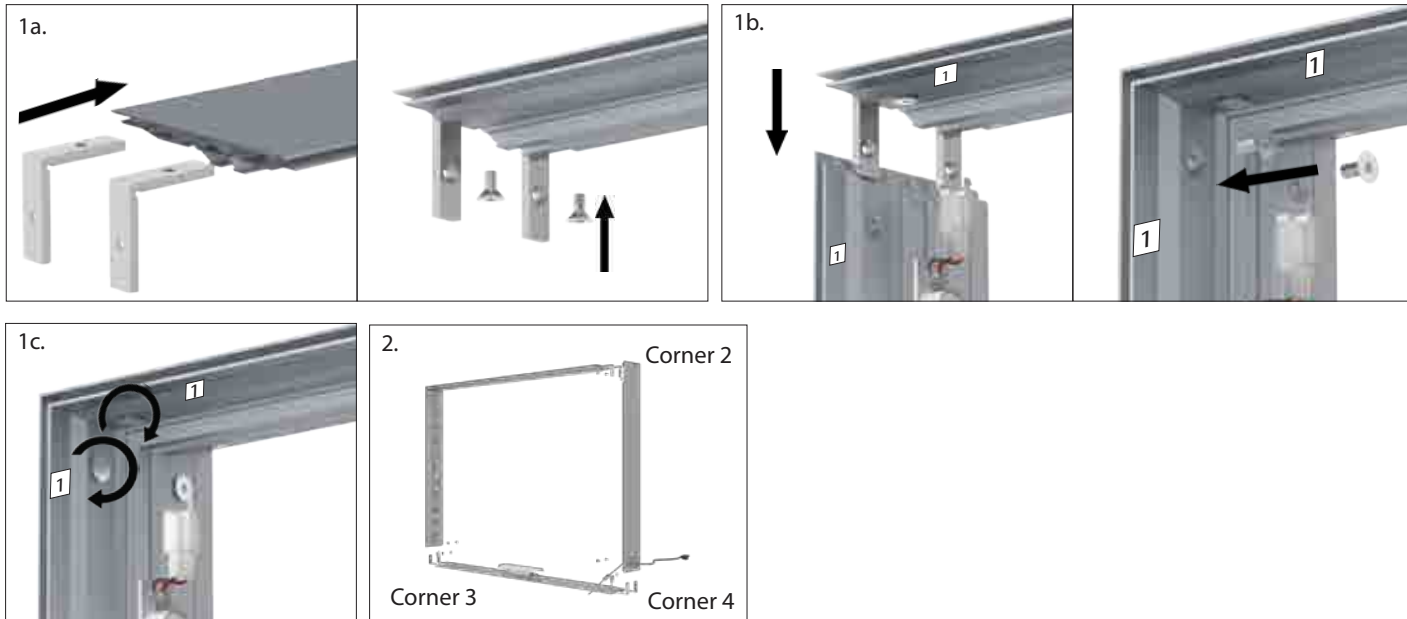
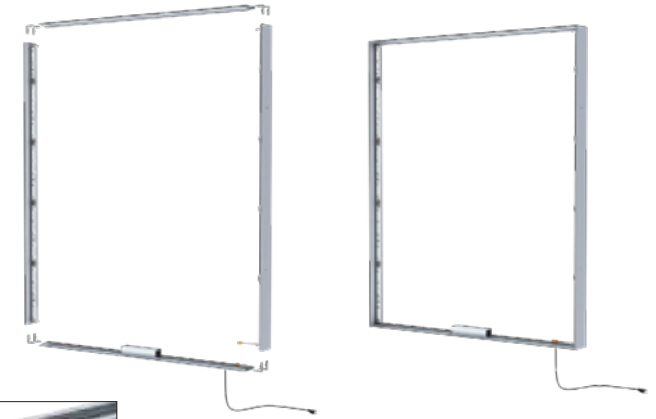

Charisma™ SEG Double Sided Light Box - XSD Series

Page 3 - Connect Electrical Components

1. At each break in the extrusion, identify the orange or white electrical connector. Then connect the white female connectors to their matching male connectors and the orange female connector to their matching male connector. The connectors must fully "click" together.
2. It is normal for the last female white connector to be unconnected to anything else.
3. If there are multiple cables, connect those with matching colors.

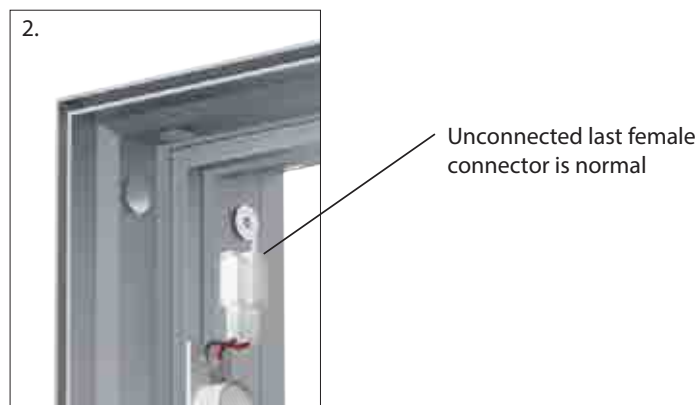
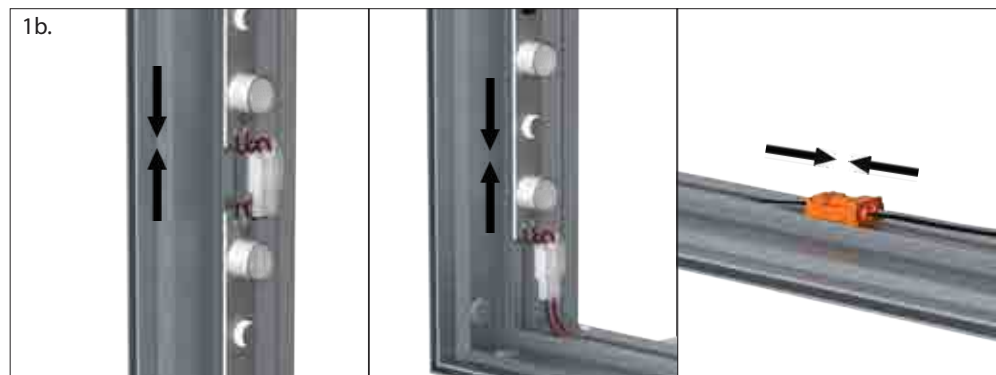

ELECTRICAL NOTE:
This sign is intended to be installed in accordance with the requirements of Article 600 of the National Electrical Code and/or other applicable codes. This includes proper grounding and bonding of the sign.

Charisma™ SEG Double Sided Light Box - XSD Series

Page 4 - Install the Graphic

1. Plug frame into wall outlet.
2. To install the graphic, take the corner with the pull tag on it and press about 6"-10" of silicone into the frame channel corner A. Repeat for the opposite corner B. Repeat for the next corner C. Lastly, repeat for the final corner D.
3. After all corners are pressed in, press the silicone into the frame channel at the mid-points on all four sides.
4. Press silicone into frame evenly between the corner and midpoints.
This prevents the graphic from bunching up or stretching too much and will ensure a smooth and tight fit.
5. Repeat steps 1-4 on the second side.
6. To remove the graphic from the frame, simply pull up on the pull tag.

NOTE: Model shown below may differ from your model, but assembly instructions remain the same.

