

# Freestanding Monitor Kiosk

PM4S3-MK-M  
PM4S3-MK-L

PM4S3-MK-M-MSHELF  
PM4S3-MK-L-MSHELF

PM4S3-MK-SHELF-UNIT

The Freestanding Monitor Kiosk is a superior multimedia display that can be used for multiple applications, as well as in trade show exhibits and for events. Kiosks include monitor mounts to support a medium or large size TV, and a corresponding medium or large shelf may be added. Monitor mounts support TV's up to 40 lbs and 32" - 65" in size, and can be adjusted to the perfect height; an included shelf can hold up to 15 lbs. The Shelf Unit is a great addition that proudly displays small products. Install the Freestanding line behind a fabric backwall for a truly impressive display.



Freestanding Monitor Kiosk



Freestanding Monitor Kiosk with Shelf



Freestanding Shelf Unit

## features and benefits:

- Premium aluminum extrusion frames with cam lock and tension glide assembly
- Easy to store and ship
- Quick to set up
- Weighted feet for added stability
- Kits may include: a medium or large monitor mount, shelf, or combination
- Choice of medium or large shelf for display opportunities (Freestanding Monitor Kiosk with Shelf or Freestanding Shelf)
- Lifetime limited hardware warranty against manufacturer defects

## dimensions:

### Hardware

Assembled unit (no shelf):  
25.59" w x 70.98" h x 25.59" d  
650mm(w) x 1803mm(h) x 650mm(d)

Assembled unit (with shelf):  
29.53" w x 70.98" h x 25.59" d  
751mm(w) x 1803mm(h) x 650mm(d)

Approximate weight:  
(excludes cases & monitor mount)

40 lbs / 19 kgs

Add 10 lbs / 5 kgs for each shelf

### Shipping

Packing case(s):  
1 OCE Case

Shipping dimensions:  
OCE: Expandable case length (l) may vary  
40" - 66" l x 18" h x 18" d  
1016mm-1677mm(l) x 458mm(h) x 458mm(d)

Approximate total shipping weight:  
Monitor Kiosk:  
(Case & monitor mount)  
Medium  
83 lbs / 38 kgs  
Large  
85 lbs / 39 kgs

## additional information:

-Medium monitor mount can hold 32-55" monitor/ max weight 40lbs

-Large monitor mount can hold 40"-65" monitor/ max weight 40lbs

-Monitor not included

-Shelf can hold suggested max weight: 15 lbs

-If shipping with backwall kit cases may vary

Monitor Kiosk with Shelf:  
(Case, monitor mount, & shelf)

Medium  
93 lbs / 43 kgs  
Large  
95 lbs / 44 kgs

Shelf Unit:  
(Case & shelves)  
116 lbs / 53 kgs

# Included In Your Freestanding Shelf

Tools, Components, Connectors & Extrusions



5MM ALLEN-T x1



PM4S3-MM-FOOT-L x1



PM4S3-MM-FOOT-R x1



LN100 x6

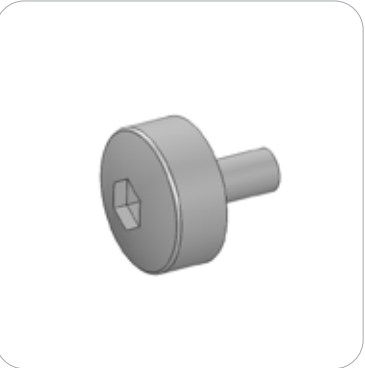

M5 THUMBSCREW x8



PH2-350-L-L x3



PM4S3-600-A165-A165 x2



PM4S3-1200-A165-A165 x2



PH2-300-TG x2

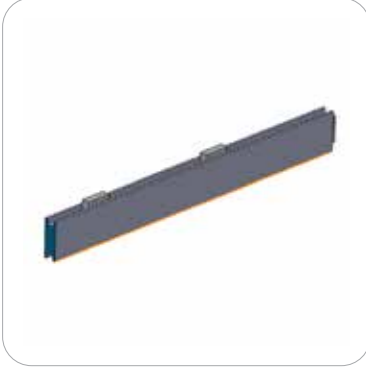

PH-400-L-SIDE-MK x6



PE-1200 x6  
\*will ship preattached to shelf



CT21-MK-SHELF x3



LN605-EN x6



# Exploded View

## PM4S3-MK-SHELF-UNIT

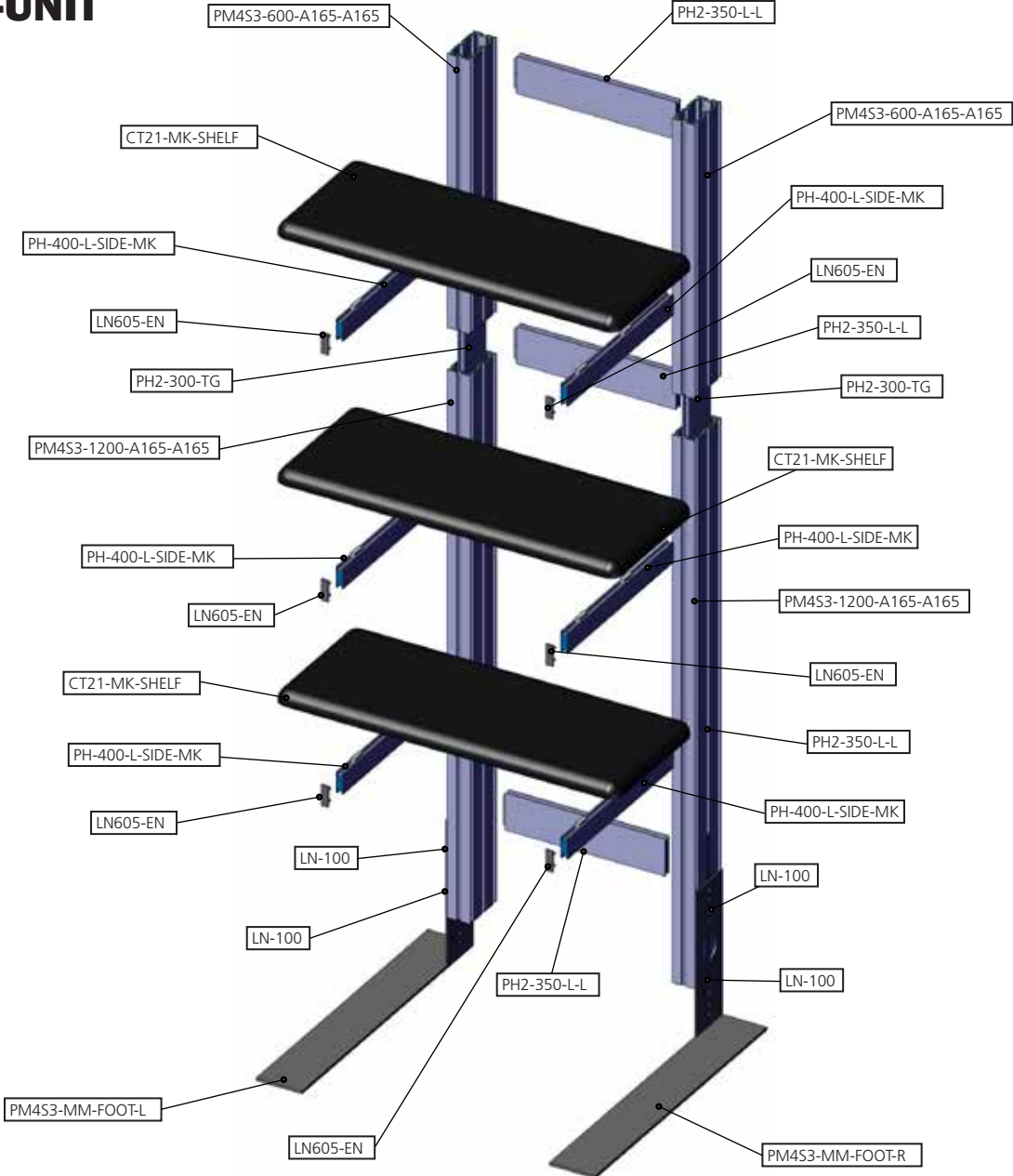

# Kit Assembly

## Step by Step

### Step 1.

Reference the image to the right. Locate the coded extrusions. Slide the PH2-300-TG connector into one end of the PM4S3-1200-A165-A165 so that it goes as deep as the internal pins. Connect the PM4S3-600-A165-A165 by sliding it over the PH2-300-TG. Repeat for this step for the second vertical.

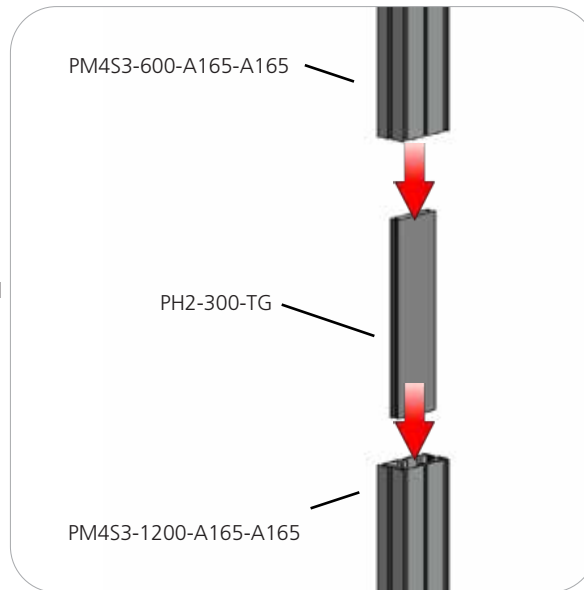

### Step 2.

Collect your extrusions and handtool. Using the provided handtool, lock the extrusions into the back channel of the three channel PM4S3 faces as shown in the image below. Be sure the locks face toward the back of the assembly and do not over tighten.

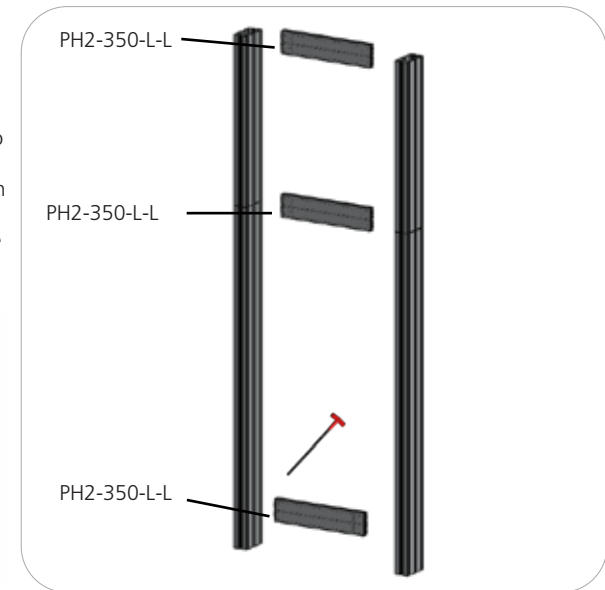
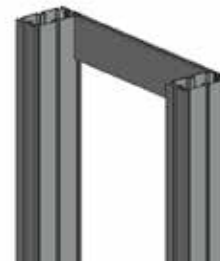

### Step 3.

Locate the M5 thumbscrews, LN100s, and the PM4S3-MM stabilizing bases. Slide the LN100s into the middle channel of the PM4S3. Hand screw the M5 thumbscrews through the base holes and into the LN100 holes. Use the handtool to securely fasten the M5 Thumbscrews. Do not over tighten.

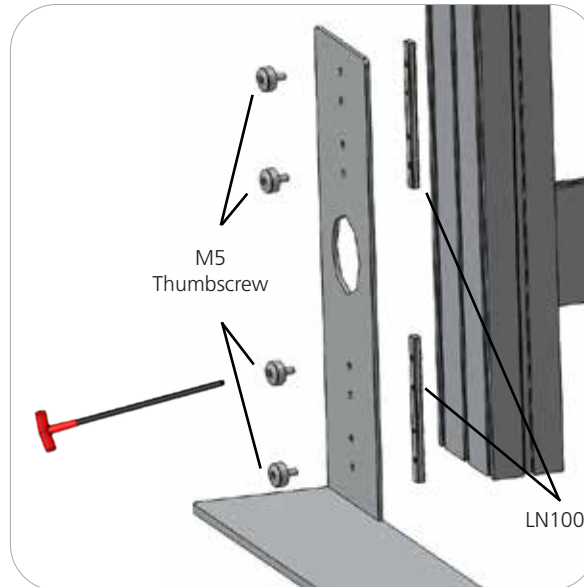

### STOP

We recommend you to move your kiosk(s) in place before continuing on with the rest of assembly.

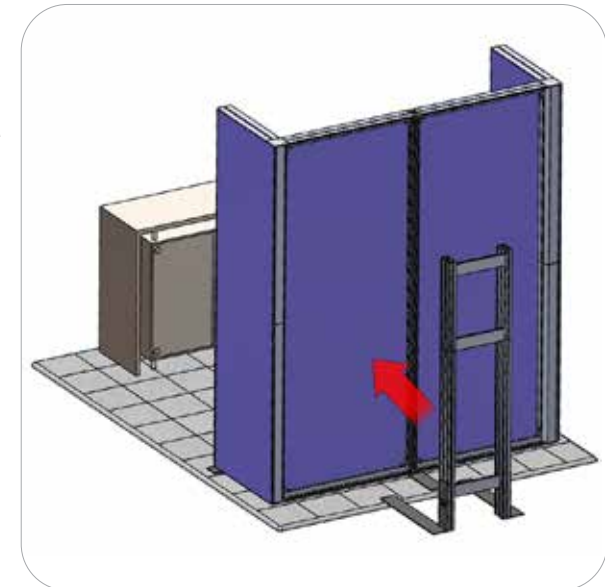

# Freestanding Display Shelf

## PM4S3-MK-SHELF

Freestanding display shelves are easily attached to your assembled kiosk for displaying promotional materials. This shelf can be added to a Freestanding Monitor Kiosk order.



### features and benefits:

- Premium aluminum extrusion frames with cam lock and tension glide assembly
- Easy to store and ship
- Quick to set up
- Lifetime limited hardware warranty against manufacturer defects
- Great for display opportunities

### dimensions:

#### Hardware

Assembled unit:  
Medium or Large

29.53" w x 6.35" h x 15.87" d  
751mm(w) x 162mm(h) x 404mm(d)

Approximate weight (shelf):  
10 lbs / 5 kgs

#### Shipping

Ships in box

Shipping dimensions:  
Special order - 30" (l) x 16" (h) x 4" (d)  
762mm(l) x 407mm(h) x 102mm(d)

Approximate total shipping weight:  
12 lbs / 6 kgs

### additional information:

- Shelf can hold suggested max weight 15lbs
- If shipping with backwall kit cases may vary

# Included In Your Freestanding Display Shelf

Components, Connectors & Extrusions

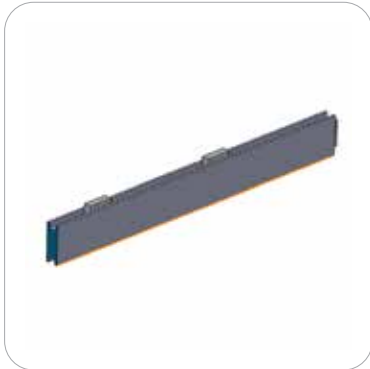

PH-400-L-SIDE-MK x2



PE-1200 x2  
\*will ship preattached to shelf



CT21-MK-SHELF x1



LN605-EN x2



# Exploded View

## PM4S3-MK-SHELF

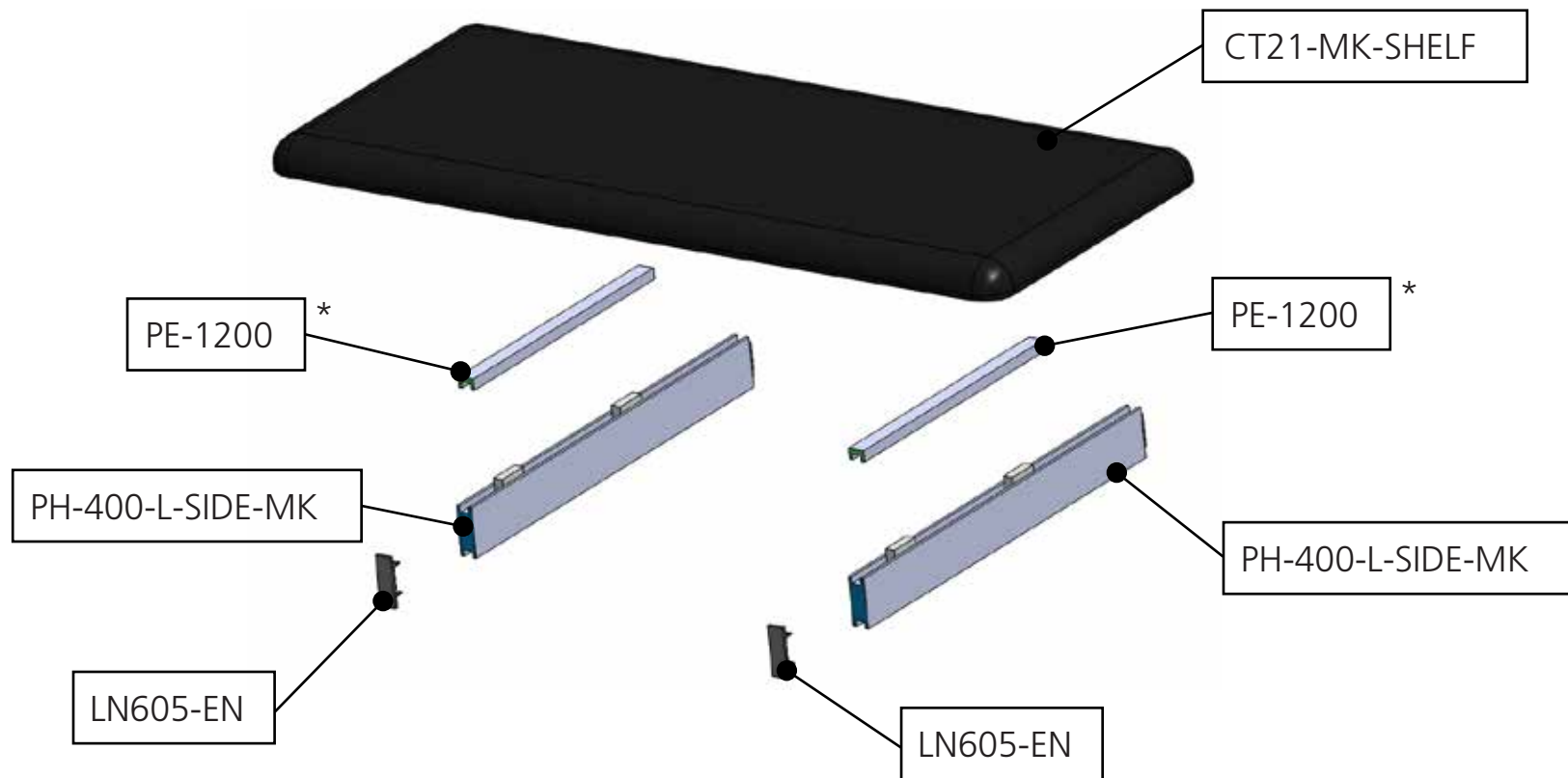

\*Note: PE will ship preattached to shelf

# Kit Assembly

## Step by Step - Shelf

### Step 8.

Insert the LN605-EN end caps. Lock the CT21-MK-SHELF to the PH-400-L-SIDE-MK. Do not over tighten.

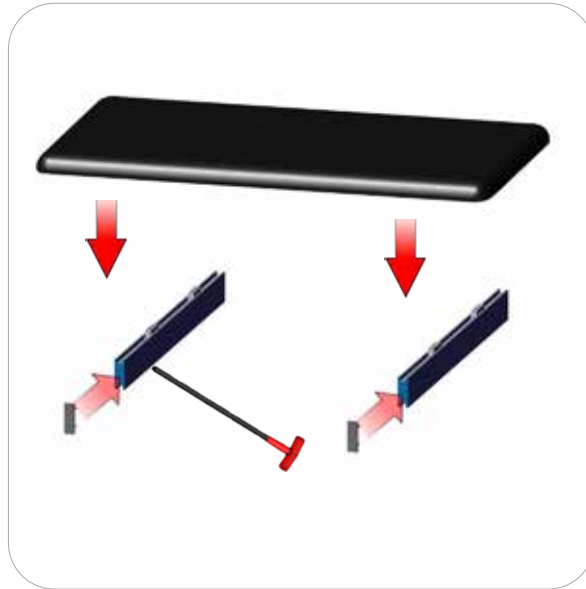

### Step 7.

Lock your PH-400-L-SIDE-MK into the PM453 stacks at the desired dimension height. Do not over tighten.

Refer to the attached supplemental sheet for details on shelf height(s).

Setup is complete.

Repeat steps 7 and 8 twice more for Shelf Unit.

