

# Vector Frame Edge

VFE-S-01      VFE-R-01  
 VFE-S-02      VFE-R-02  
 VFE-S-03      VFE-R-03  
 VFE-S-04      VFE-R-04  
 VFE-S-05

Vector Frame™ Edge fabric poster displays combine durable, slim lightweight less than 1" aluminum extrusion frames and easy-to-apply push-fit fabric graphics. Custom frame sizes are available.

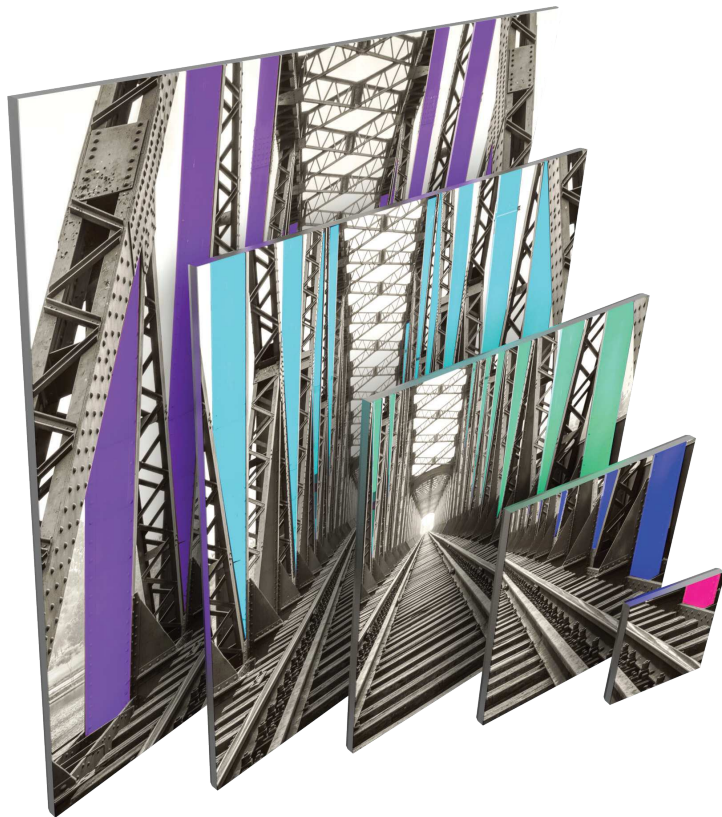

## features and benefits:

- Lightweight, low profile aluminum frame
- Easy-to-apply push-fit fabric graphic
- Wall mounting hardware not included
- Custom frame sizes are available
- Lifetime hardware warranty against manufacturer defects

## dimensions:

### Hardware

**VFE-S-01:** 11.8" w x 11.8" h x .79" d  
 300mm(w) x 300mm(h) x 20mm(d)  
 Assembled Weight: 1 lb / 1 kg  
**VFE-S-02:** 23.62" w x 23.62" h x .79" d  
 600mm(w) x 600mm(h) x 20mm(d)  
 Assembled Weight: 2 lb / 1 kg  
**VFE-S-03:** 35.43" w x 35.43" h x .79" d  
 900mm(w) x 900mm(h) x 20mm(d)  
 Assembled Weight: 3 lb / 2 kg  
**VFE-S-04:** 47.24" w x 47.24" h x .79" d  
 1200mm(w) x 1200mm(h) x 20mm(d)  
 Assembled Weight: 3 lb / 2 kg  
**VFE-S-05:** 59.06" w x 59.06" h x .79" d  
 1500mm(w) x 1500mm(h) x 20mm(d)  
 Assembled Weight: 4 lb / 2 kg

**VFE-R-01:** 11.8" w x 23.62" h x .79" d  
 300mm(w) x 600mm(h) x 20mm(d)  
 Assembled Weight: 2 lb / 1 kg  
**VFE-R-02:** 11.8" w x 35.43" h x .79" d  
 300mm(w) x 900mm(h) x 20mm(d)  
 Assembled Weight: 2 lb / 1 kg  
**VFE-R-03:** 23.62" w x 35.43" h x .79" d  
 600mm(w) x 900mm(h) x 20mm(d)  
 Assembled Weight: 2 lb / 1 kg  
**VFE-R-04:** 23.62" w x 47.24" h x .79" d  
 600mm(w) x 1200mm(h) x 20mm(d)  
 Assembled Weight: 2 lb / 1 kg

### Shipping

**VFE-S-01:** 28" l x 6" h x 6" d  
 712mm(l) x 153mm(h) x 153mm(d)  
 Shipping Weight: 2 lb / 1 kg  
**VFE-S-02:** 28" l x 6" h x 6" d  
 712mm(l) x 153mm(h) x 1530mm(d)  
 Shipping Weight: 3 lb / 2 kg  
**VFE-S-03:** 38" l x 5" h x 5" d  
 966mm(l) x 127mm(h) x 127mm(d)  
 Shipping Weight: 4 lb / 2 kg  
**VFE-S-04:** 50" l x 6" h x 6" d  
 1270mm(l) x 153mm(h) x 153mm(d)  
 Shipping Weight: 5 lb / 3 kg  
**VFE-S-05:** 62" l x 5" h x 5" d  
 1575mm(l) x 127mm(h) x 127mm(d)  
 Shipping Weight: 6 lb / 3 kg

**VFE-R-01:** 28" l x 6" h x 6" d  
 712mm(l) x 153mm(h) x 153mm(d)  
 Shipping Weight: 3 lb / 2 kg  
**VFE-R-02:** 38" l x 5" h x 5" d  
 966mm(l) x 127mm(h) x 127mm(d)  
 Shipping Weight: 3 lb / 2 kg  
**VFE-R-03:** 38" l x 5" h x 5" d  
 966mm(l) x 127mm(h) x 127mm(d)  
 Shipping Weight: 3 lb / 2 kg  
**VFE-R-04:** 50" l x 6" h x 6" d  
 1270mm(l) x 153mm(h) x 153mm(d)  
 Shipping Weight: 4 lb / 2 kg

### Graphic

Refer to related graphic template for more information.

Visit:  
[www.exhibitors-handbook.com/graphic-templates](http://www.exhibitors-handbook.com/graphic-templates)

## additional information:

Graphic material:  
 Dye-sublimation SEG push-fit fabric  
 Recommended Tools for Installation:  
 screw driver, spirit level, wall stud finder,  
 fastening screws and a pencil  
 (tools and hanging hardware not included)

We are continually improving and modifying our product range and reserve the right to vary the specifications without prior notice. All dimensions and weights quoted are approximate and we accept no responsibility for variance. E&OE. See Graphic Templates for graphic bleed specifications.

# Connection Methods

## Connection Method 1: VF-CC

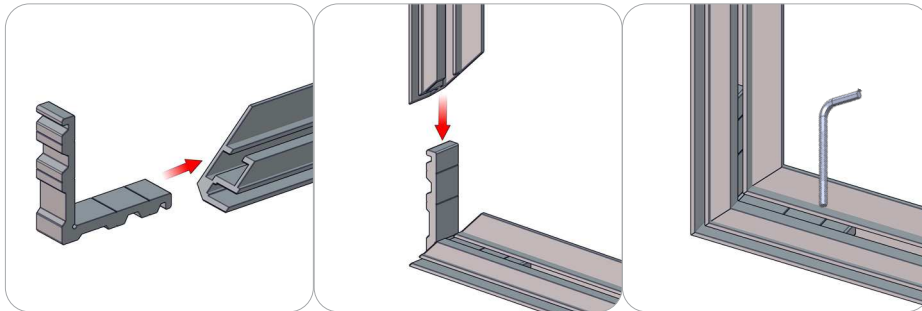

First, insert the corner connector into the extrusion. Then, slide the next extrusion onto the same corner connector. Finally, hold the corner components together and use the provided Allen Key to lock the corner connector in place.

## Connection Method 2: VF-SJ

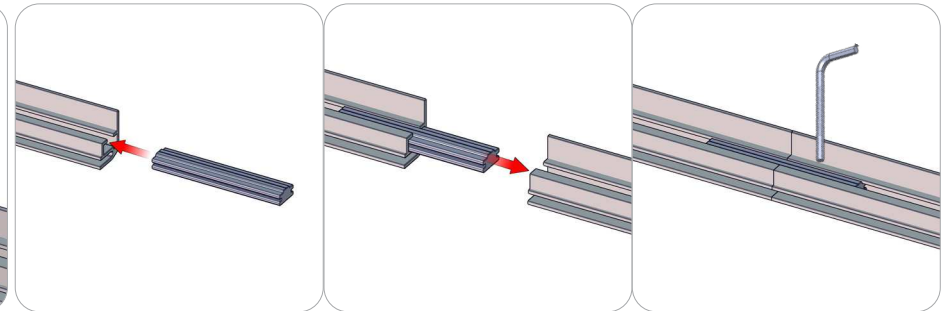

First, insert the straight connector into the extrusion. Then, slide the next extrusion onto the same straight connector. Finally, hold the components together and use the provided Allen key to lock the corner in place.

## Connection Method 3: Frame to Wall with Studs

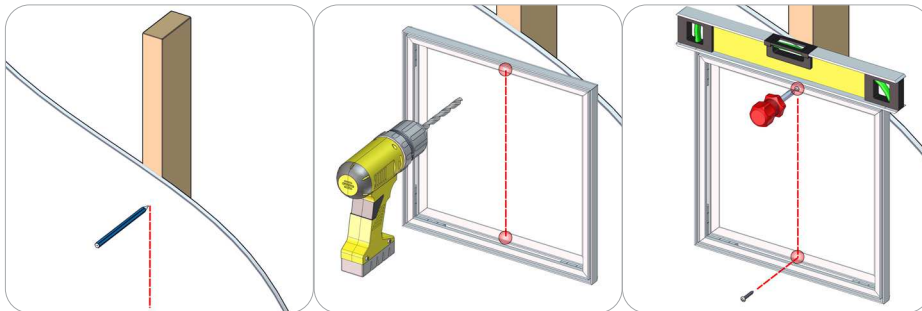

First, find the wall studs and mark it with a pencil. You can use a stud finder to help locate the studs. Second, drill holes on the frame for screw clearance. Do not make the holes larger than the screw heads. Make sure to drill on center for top and bottom horizontal frame runs. Third, level and hold the frame in place lining up the frame holes with the pencil line. Finally, use a hand screw driver to secure the frame onto the wall with screws. (tools and hanging hardware not included)

## Connection Method 4: Graphic Application

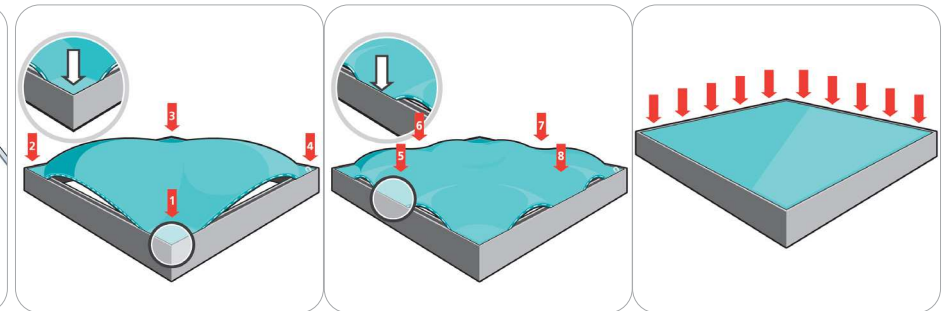

First, insert the silicone edge fabric corners into the frame extrusion graphic channel (points 1 through 4). Second, insert the silicone edge fabric sides into the frame extrusion graphic channel (points 5 through 8). Third, push the remaining silicone edge into the frame extrusion graphic channel.

# Kit Assembly

## Step by Step

### Step 1.

Gather the components to build the frame. Use the provided hex key to fasten the extrusion connectors.

Reference Connection Method(s) 1 and 2 for more details.

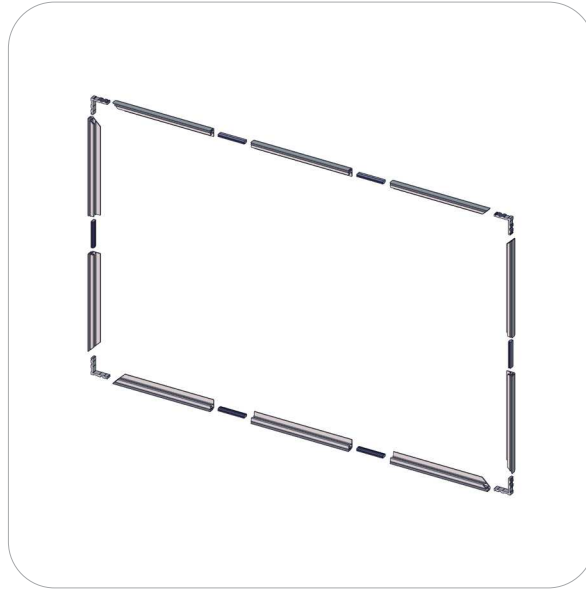
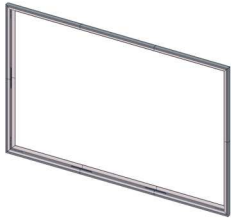

### Step 2.

Take the frame and attach it to a wall or surface of proper placement. Use the recommended tools and fasteners for applying the frame.

Reference Connection Method(s) 3 for more details.

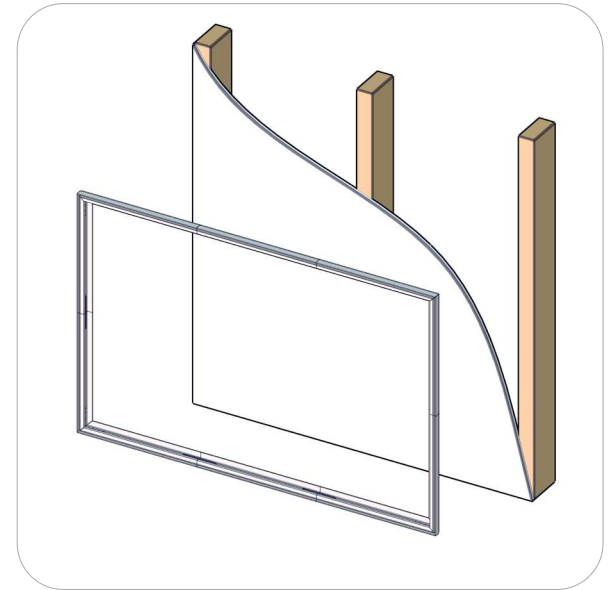
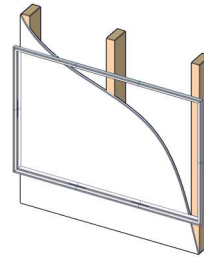

### Step 3.

Take the silicone edge graphic and attach it to the frame.

Reference Connection Method(s) 4 for more details.

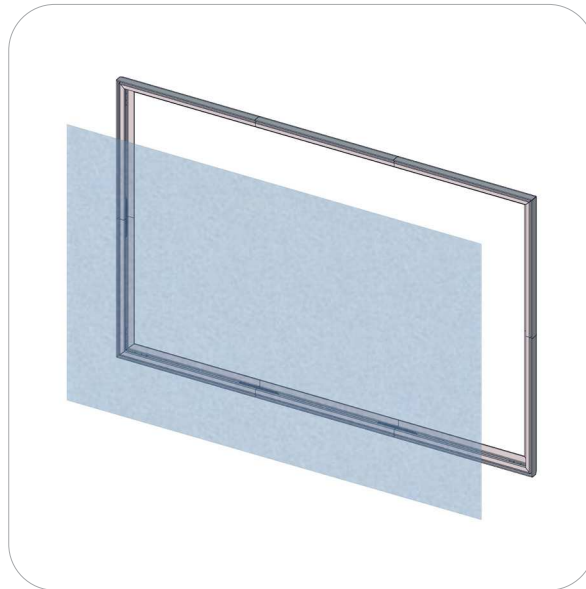
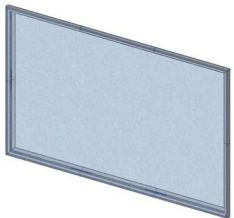

### Step 4.

Setup is complete.

