

# SACAGAWEA

DESIGNS

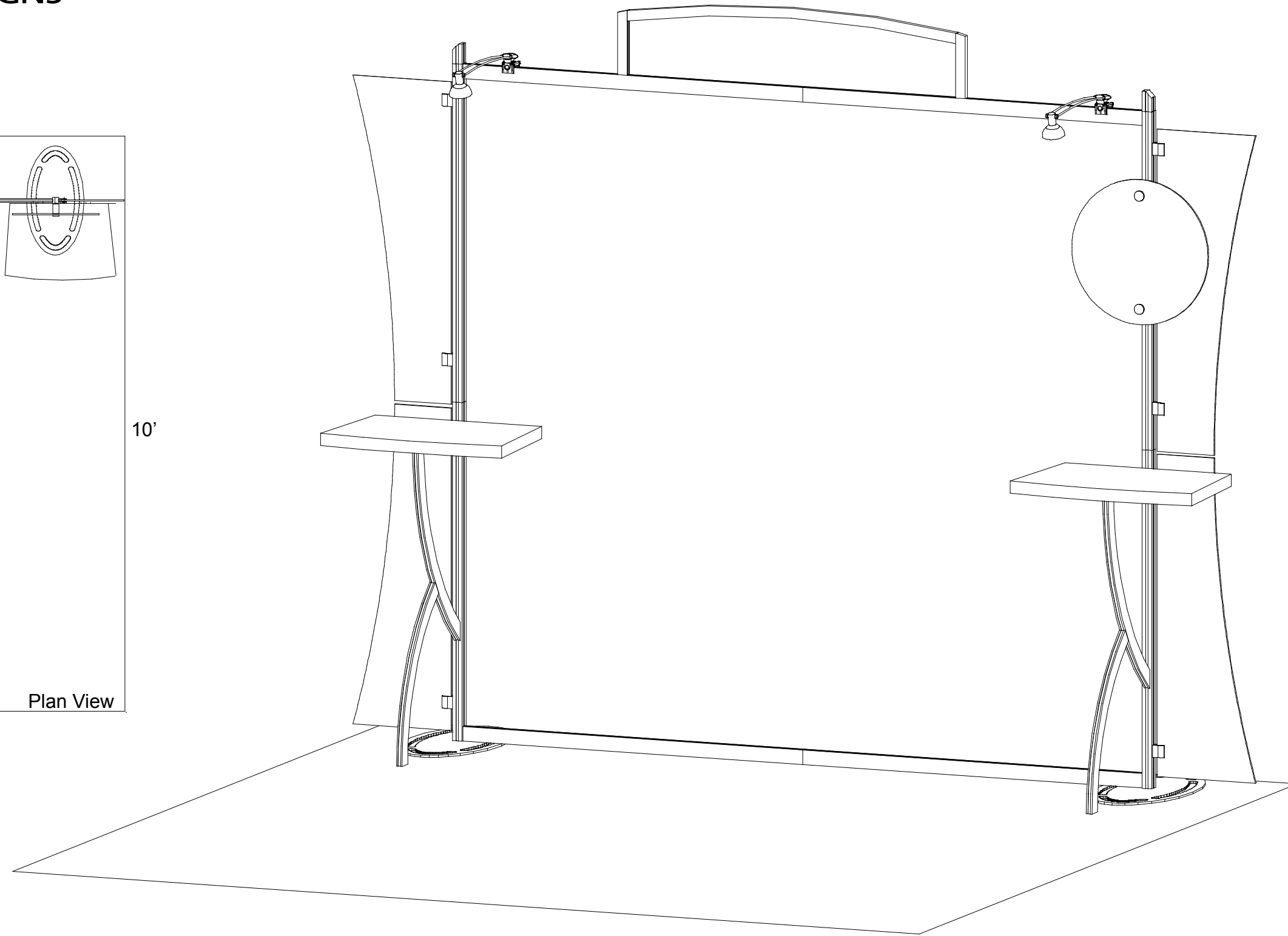
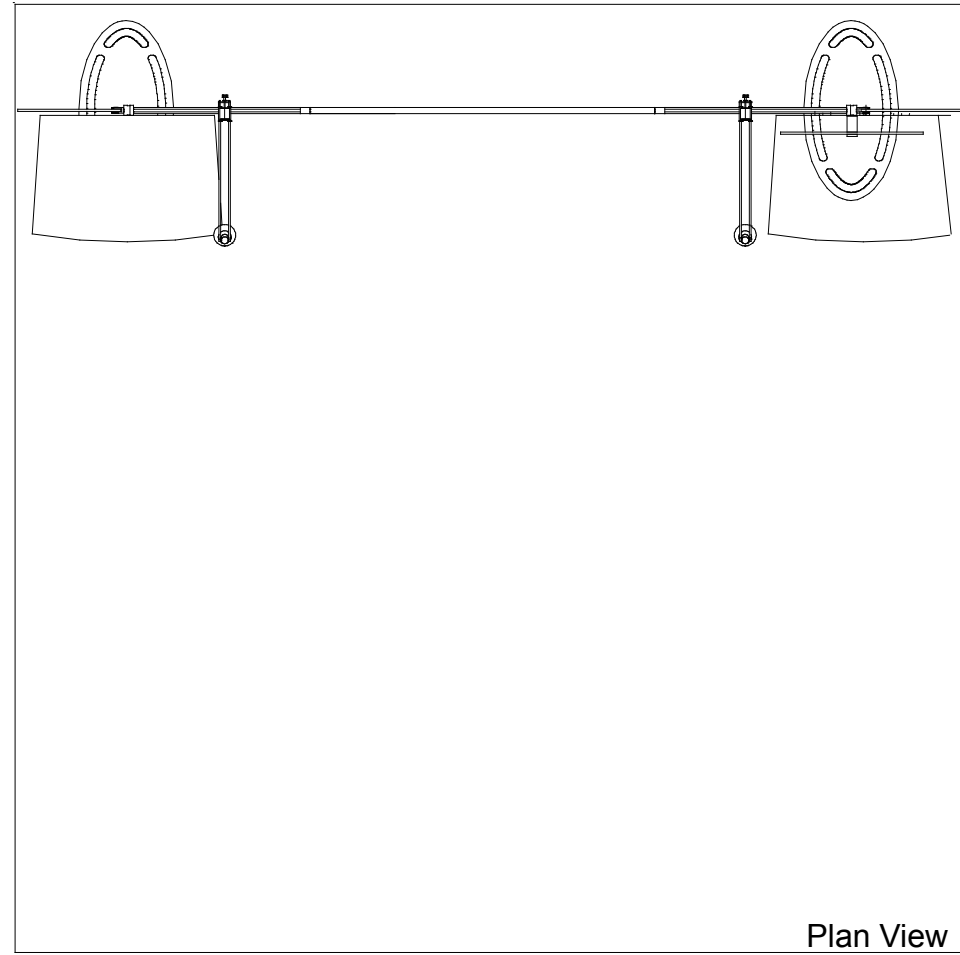

WHEN DISASSEMBLING ALUMINUM EXTRUSION, TIGHTEN ALL SETSCREWS AND LOCKS TO PREVENT LOSS DURING SHIPPING

# SACAGAWEA DESIGNS

## Using Your Set-up Instructions:

The Visionary Designs Set-up Instructions for Sacagawea displays are created specifically for your configuration. They are laid out sequentially, including an exploded view of the entire display and a logical series of detailed steps for assembly. We encourage you to study the instructions **before** attempting to assemble your exhibit.

### THIS IS VERY IMPORTANT!

Each page reminds you to tighten the setscrews after disassembling your exhibit to prevent loss of the locks and setscrews (see below in red).

## Cleaning & Packing Your Display:

- 1) Use care when cleaning aluminum extrusions or acrylic inserts. Use only non-abrasive cleaners.
- 2) When cleaning laminate inserts or counter tops, use mild cleansers and a soft material such as cotton.
- 3) Keep all display components away from extreme heat and long exposure to sunlight to avoid warping and fading.
- 4) Retain all packing materials. It will make re-packing much easier and will reduce the likelihood of shipping damage.

Hex Key Tool



Most visionary design exhibits can be assembled with the supplied Hex Key Tool. Occasionally, a flat head screwdriver may be required.

Typical Connection



Detail A: Most horizontal extrusion connections have a patented expandable lock. This lock inserts into the groove of an opposing extrusion. Tightening the lock with the Hex Key Tool expands the lock and creates a strong positive connection.

Typical Connection

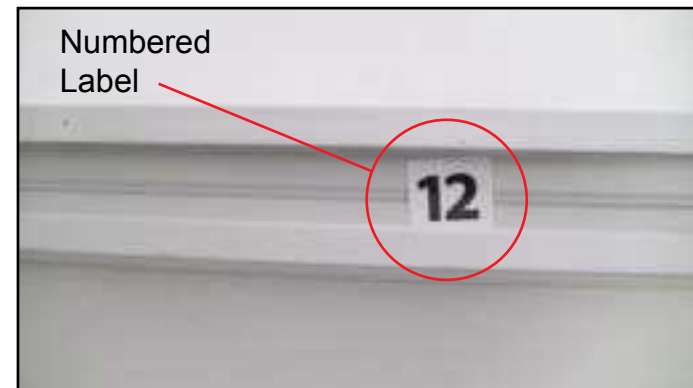

Detail B: Each extrusion contains a numbered label that corresponds to set-up instructions. The label is located within a groove of the extrusion (when possible). Visionary Design labels contain Black numbers unless otherwise specified.

Horizontal Connection

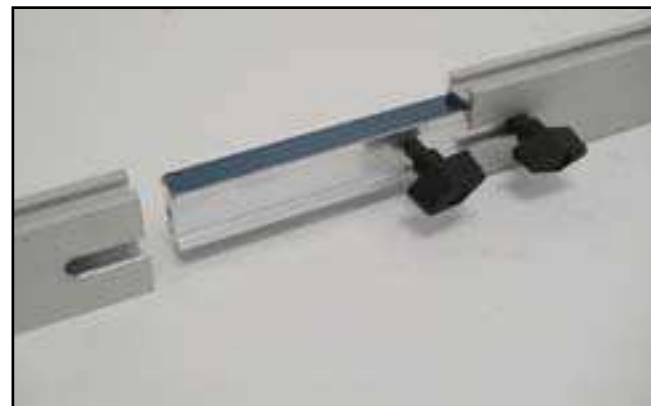

Detail C: A rectangular connection bar with plastic T Knobs is inserted between two horizontal extrusions joined end-to-end. Turn the knobs clockwise to tighten.

Do Not Overtighten.

Base Plate Connection



Detail D: Attach vertical extrusions to base plates with supplied bolts inserted through the hole in the plate. Be careful not to strip the thread.

Vertical Connection



Detail E: A square connection bar with plastic T Knobs is inserted between two vertical extrusions joined end-to-end. Turn the knobs clockwise to tighten.

Do Not Overtighten.

Corner Connection



Detail F: Plastic Star Knobs are used to tighten locks where horizontal extrusions connect with vertical extrusions. Turn the knobs clockwise to tighten. Turn counter-clockwise to loosen, but do not remove knob.

Do Not Overtighten.

**WHEN DISASSEMBLING ALUMINUM EXTRUSION, TIGHTEN ALL SETSCREWS AND LOCKS TO PREVENT LOSS DURING SHIPPING**

| Item  | Qty. | Description              |
|-------|------|--------------------------|
| 1     | 2    | Base Plate               |
| 2a/2b | 1/1  | 42" Vertical Extrusion   |
| 3a/3b | 1/1  | 42" Vertical Extrusion   |
| 4a/4b | 1/1  | 45" Horizontal Extrusion |
| 5a/5b | 1/1  | 45" Horizontal Extrusion |
| 6a/6b | 1/1  | 2.5" Angle-Cut Vertical  |

- Steps:
- 1) Attach base plates [1] to lower verticals [2a,3a] with bolts.
  - 2) Connect upper verticals [2b,3b] to lower verticals [2a,3a] with connection bars [b].
  - 3) Connect horizontals [4a,4b] and [5a,5b] with connection bars [a].
  - 4) Connect vertical assemblies [2a/2b,3a/3b] with horizontal assemblies [4a/4b,5a/5b] as shown.
  - 5) Connect angled verticals [6a,6b] to upper verticals as shown.
  - 6) Attach graphics to **hook & loop** on back side of frame.

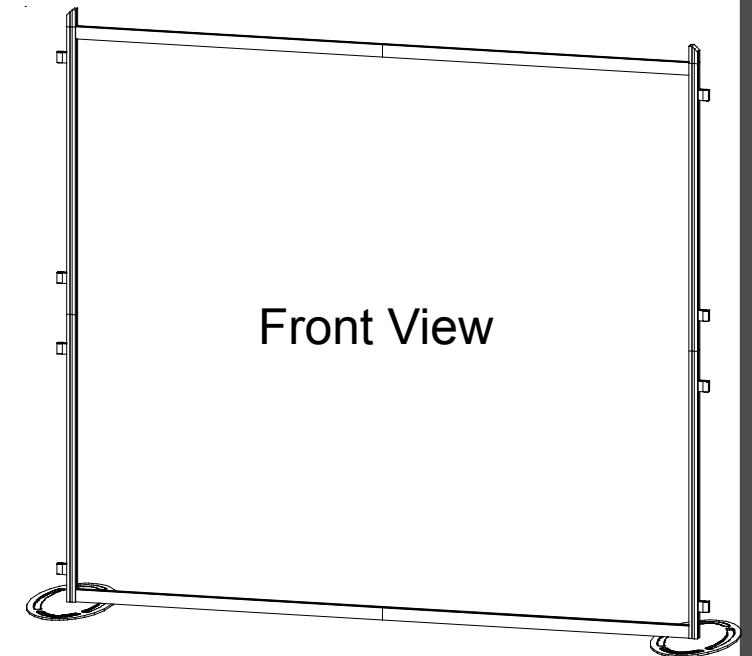

☆ indicates location of knobs on BACKSIDE of unit.

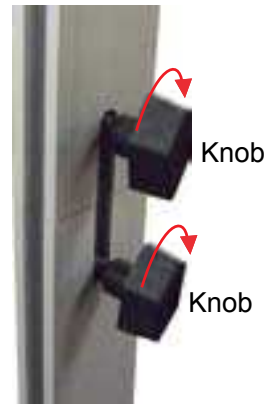

Turn Knob Clockwise to Tighten Lock  
Do not over tighten Knobs

☆ indicates location of connection lock with knob.

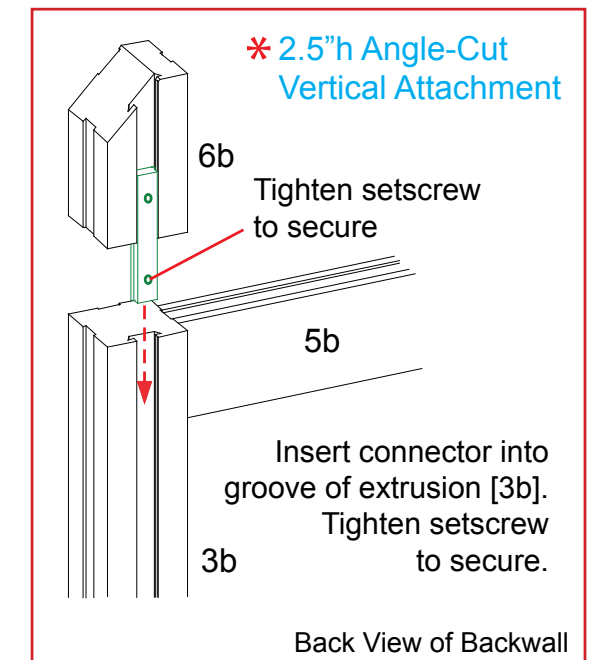
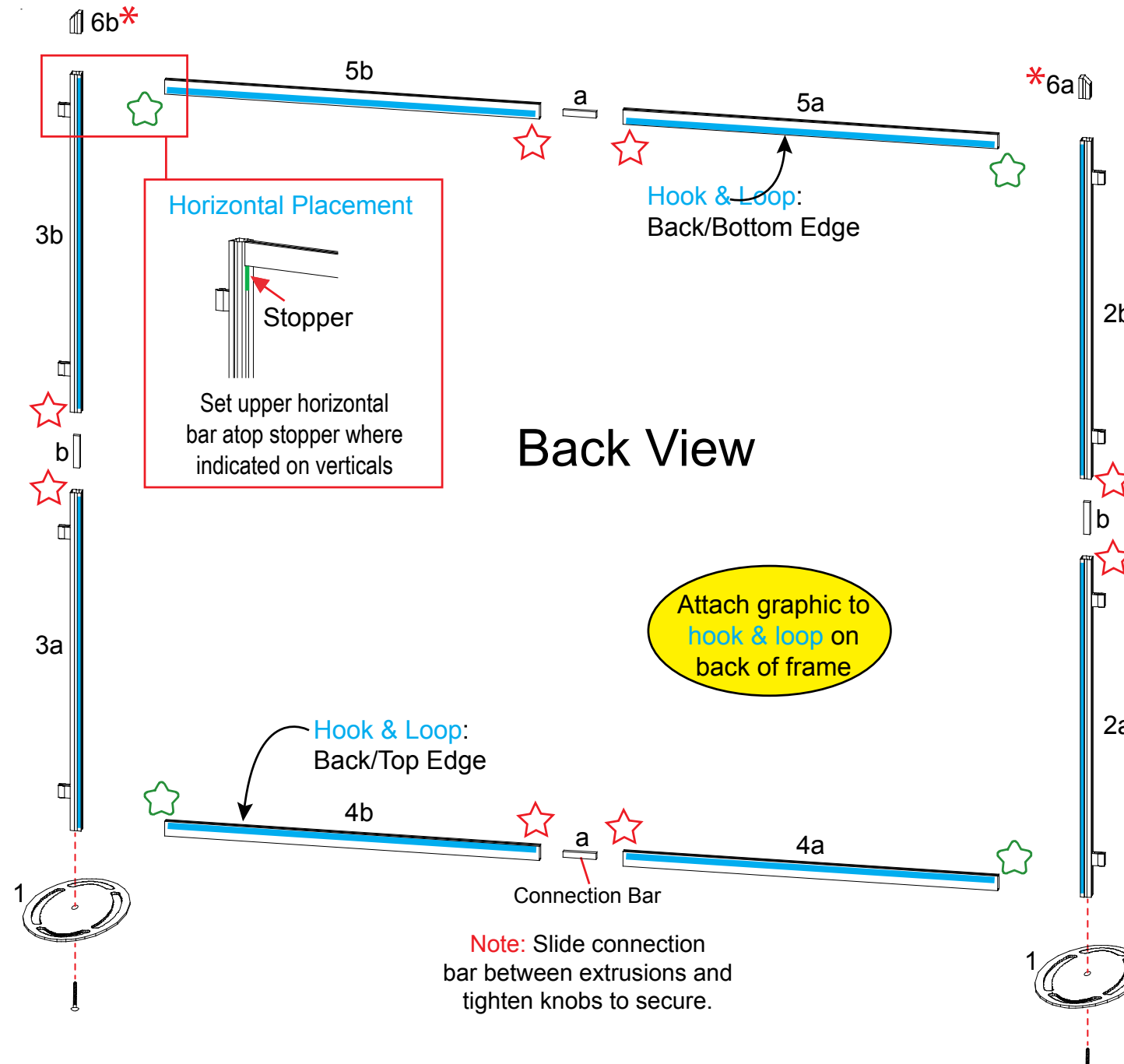

WHEN DISASSEMBLING ALUMINUM EXTRUSION, TIGHTEN ALL SETSCREWS AND LOCKS TO PREVENT LOSS DURING SHIPPING

Steps:

- 1) Attach lights as indicated.
- 2) Attach assembled header frame and apply graphics as shown.
- 3) Attach assembled counter supports [10/11] to vertical where indicated.
- 4) Attach support legs [10a] to counter support [10/11].
- 5) Attach flange plates [11a] to top of curved extrusions [10] as shown.
- 6) Attach counter tops to supports, see [counter top attachment](#) detail.
- 7) Attach wings to A10 clamps as shown.
- 8) Attach round sign to backwall frame as indicated.

| Item  | Qty.  | Description                   |
|-------|-------|-------------------------------|
| 7/8/9 | 1/1/1 | Header Frame                  |
| 10    | 2     | 30.2" Curved Extrusion        |
| 10a   | 2     | Leg Support                   |
| 11    | 2     | 12.184"w Horizontal Extrusion |
| 11a   | 2     | Flange Plate                  |

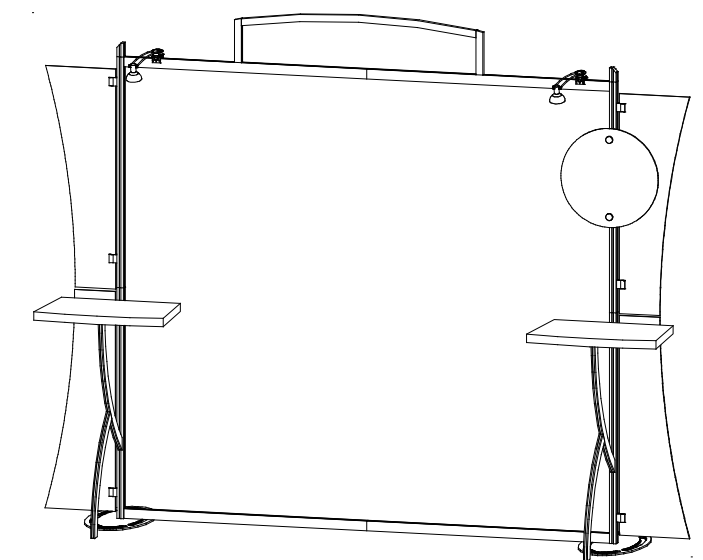

Note: Header frame ships and packs assembled

Attach monitor mount back plate to connectors using setscrews provided.

Wing Attachment

Slide A10 Clamp into groove of square extrusion.

When desired location is found, tighten set screw to secure.

Tighten black plastic set screw to secure Wing in place.

Keep A10 clamps attached to verticals

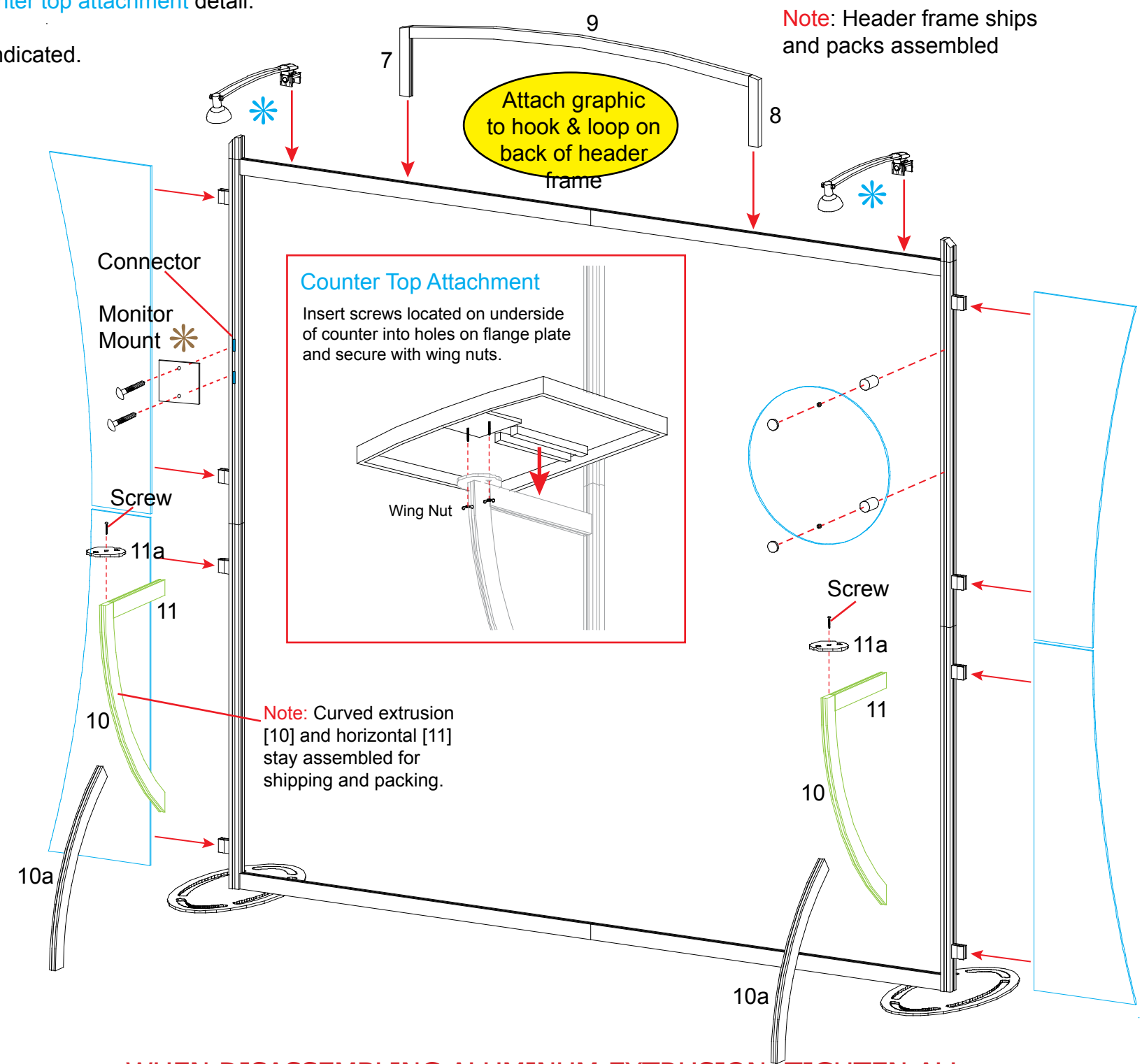

Graphic Attachment

Slide connector on back of standoff barrel into groove of extrusion and twist to secure in place. Secure graphic to standoffs using screw cap.

WHEN DISASSEMBLING ALUMINUM EXTRUSION, TIGHTEN ALL SETSCREWS AND LOCKS TO PREVENT LOSS DURING SHIPPING

Top Veiw of each Level

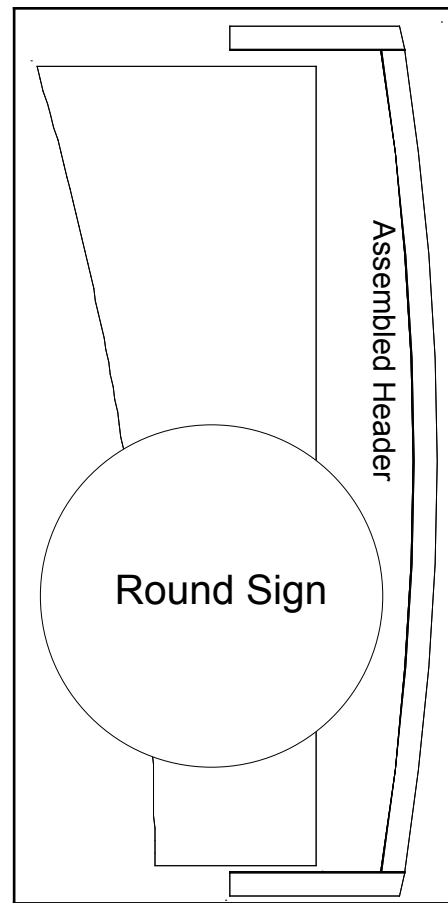

Level 1

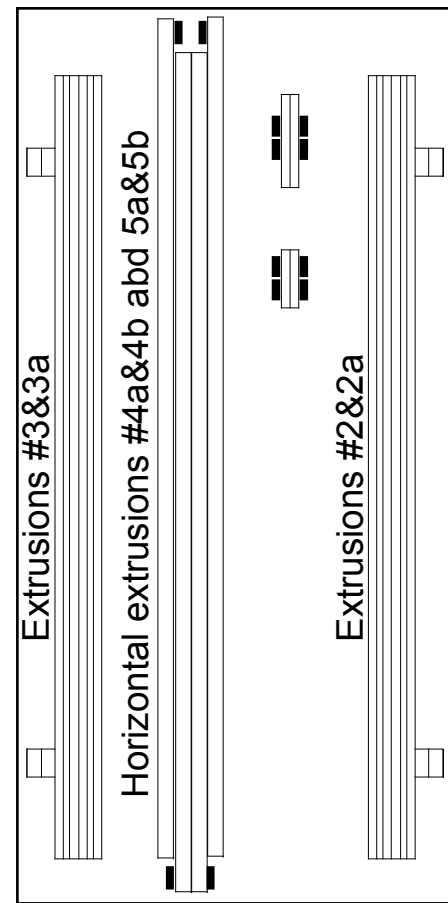

Level 2

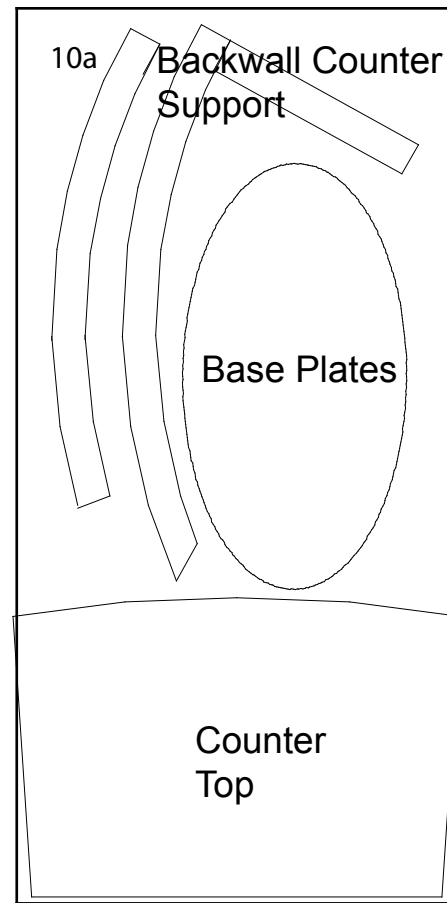

Level 3

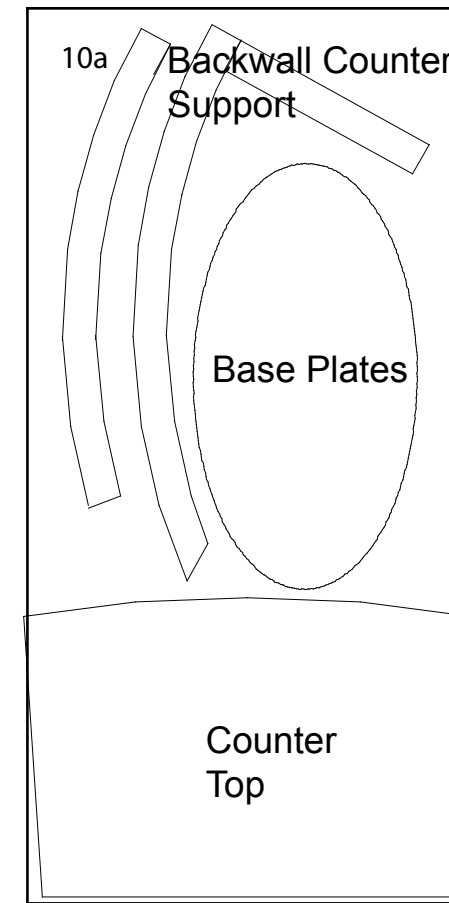

Level 4

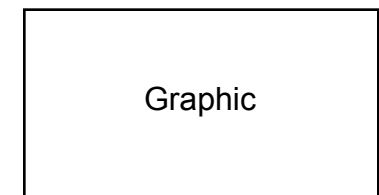
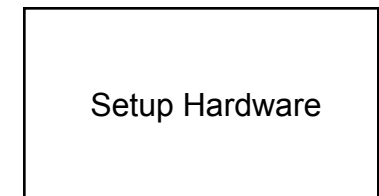

WHEN DISASSEMBLING ALUMINUM EXTRUSION, TIGHTEN ALL SETSCREWS AND LOCKS TO PREVENT LOSS DURING SHIPPING