

Side-mount Merchandising Bowl

Parts List:

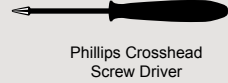
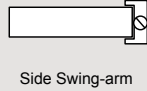
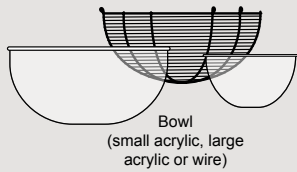

Required Tools

1. From the bottom, insert Screw through Swing-arm, 1st Washer, Bowl, and 2nd Washer. (*Illustration A*)
2. If your Bowl comes with a Sign Holder, please follow instructions on back of this sheet and attach Sign Holder's Sign Base. With a Sign Holder, there is no need to use the Nut.
3. From the top, tighten the Acorn Nut* onto the exposed end of the Screw.
(*Illustration B*)
*The Nut contains locking glue which is activated once tightened.
4. Determine the desired position of the Bowl on the Beltrac® Post. Attach the Bowl to Post by loosening the hinge grip with the supplied Allen wrench. Insert hinge grip into post groove and re-tighten. (*Illustration C*)
5. Adjust the angle of the Side-swing Arm by loosening the top screw on the hinge grip. Re-tighten to secure in desired position. (*Illustration D*)

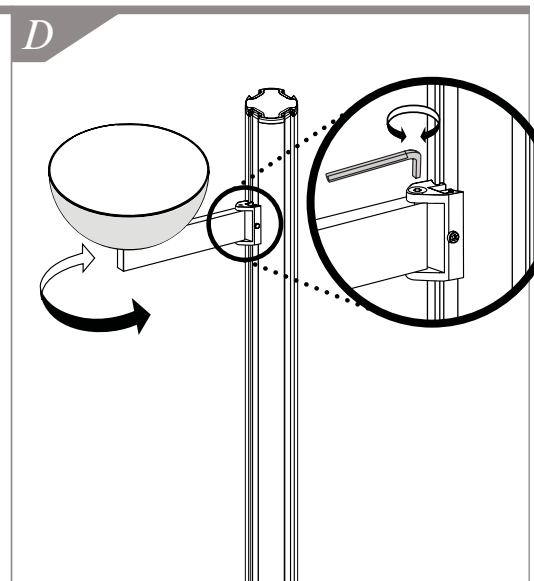
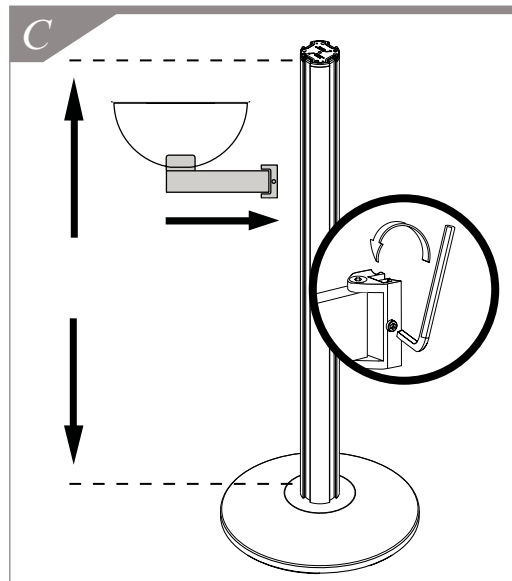
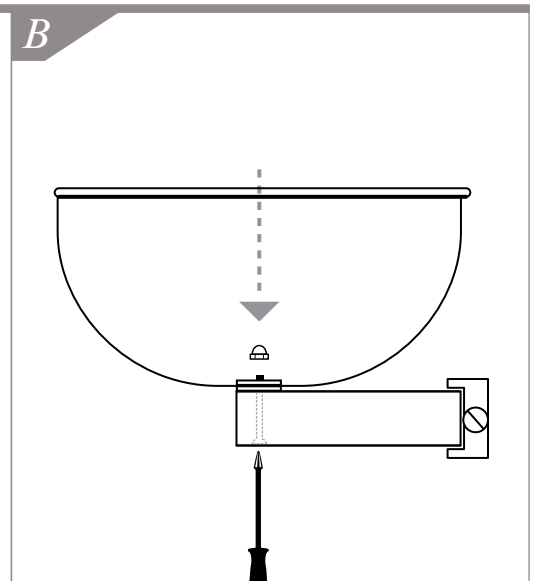
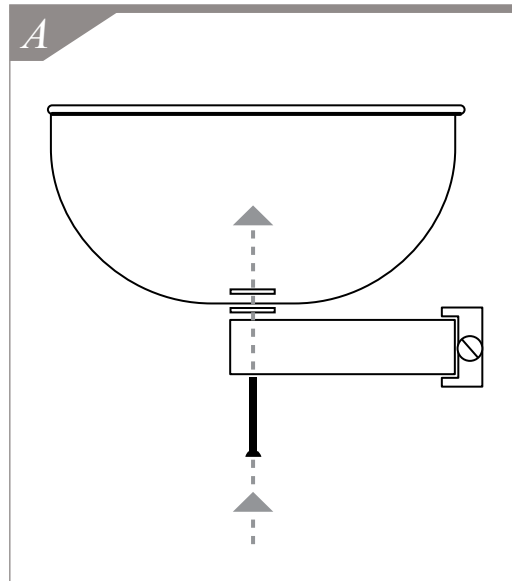

Sign Holder for Merchandising Bowl

Parts List:

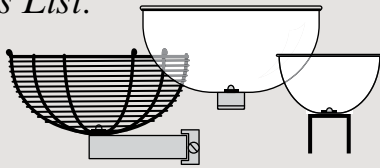

Bowl with mounting assembly as described on other side of this sheet.



Sign Holder with Magnetic Foot



Sign Base



Goggles



Phillips Crosshead Screw Driver

Required Tools

1. Install Sign Base on top of 2nd Washer. Tighten screw to secure.
(Illustration E)
2. Remove Magnetic Foot from the acrylic Sign Holder. Insert graphic into Sign Holder. Replace Magnetic Foot. Graphic size: 8" x 2.5"
(Illustration F)
3. Place Sign inside Bowl, attaching Sign Holder to Base by means of the magnet inside the Sign Foot.
(Illustration G)

