

# peerless®

*Solid Solutions - Solid Support™*

## Installation and Assembly: Flat Panel Stand for 50" - 71" Plasma Screens

Model: FPZ-670

---

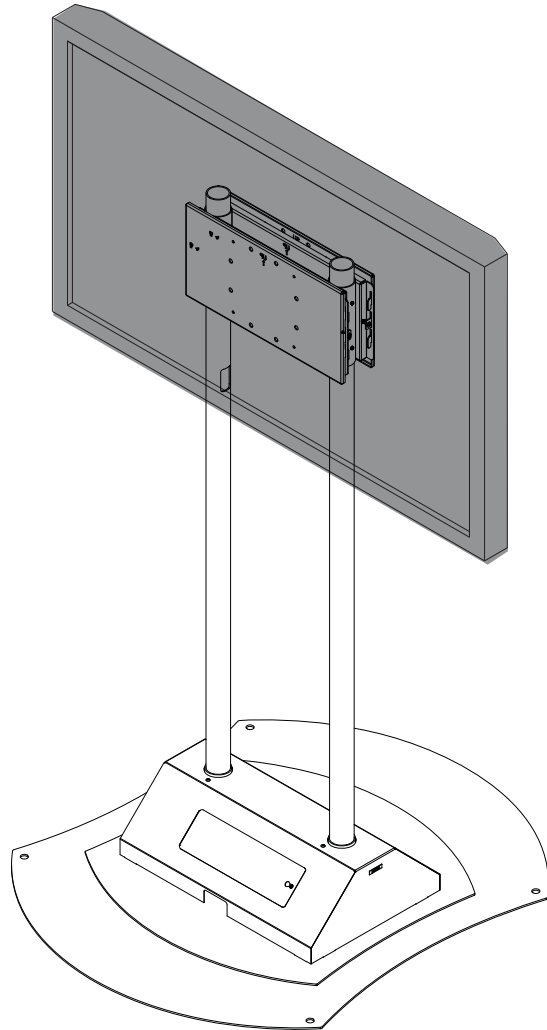

### Features:

- Fits single or back-to-back 50" - 71" flat panel screen
- Up to Vesa screens with additional PLP screen
- Supports non-Vesa screens with adapter plate (sold separately)
- Internal cable management to easily route cords from the screen to the base of the stand
- Base cover is designed to conceal content drivers and surge protectors
- Vertical adjustment on 6" columns for ideal screen viewing height
- Hook-on design allows screen to rest in place while screen is being secured
- Portrait or landscape orientation

Max Load Capacity 400 lb (181.4 kg)  
200 lb (90.7 kg) Max Load Capacity per screen

---

**Note:** Read entire instruction sheet before you start installation and assembly.

## **⚠ WARNING**

- Do not begin to install your Peerless product until you have read and understood the instructions and warnings contained in this Installation Sheet. If you have any questions regarding any of the instructions or warnings, please call Peerless customer care at 1-800-729-0307.
- This product should only be installed by someone of good mechanical aptitude, has experience with basic building construction, and fully understands these instructions.
- Make sure that the supporting surface will safely support the combined load of the equipment and all attached hardware and components.
- Never exceed the Maximum Load Capacity.
- Always use an assistant or mechanical lifting equipment to safely lift and position equipment.
- Tighten screws firmly, but do not overtighten. Overtightening can damage the items, greatly reducing their holding power.

## **Table of Contents**

---

Parts List .....	3
Floor Stand Assembly .....	4
Attaching Adapter Plate to Screen with VESA 200 x 200 Mounting Pattern .....	6
Attaching Adapter Plate to PLP Adapter Bracket .....	6
Installing Flat Panel Screen on Floor Stand .....	7

---

# Parts List

Description	Qty.	Part #
A main tube	2	580-1159
B base	1	104-1055
C carriage	1	104-1063
D adapter plate	2	104-1065
E base cover	1	104-1068
F cable access cover	1	130-1153
G M5 x 8 mm socket pin screw	2	520-1062
H M4 x 10 mm phillips screw	4	504-9012
I M4 x 20 mm	4	504-9020
J M6 x 12 mm pan head	4	520-1128
K M6 x 20 mm phillips screw	4	520-9402
L M6 x 30 mm phillips screw	4	510-9109
M 128 x 313 x 437H retaining spacer	4	590-5005
N M10 x 15 mm socket screw	4	520-9262
O M6 x 20 mm serrated washer head socket pin screw	4	510-9554
P bumper strip	1	570-1030
Q 5/16-24 x 1/4 set screw	8	520-9566
R 6 mm allen wrench	1	560-9716
S 4 mm allen wrench	1	560-9646
T M5 x 10 mm socket pin serrated washer head	1	510-1126

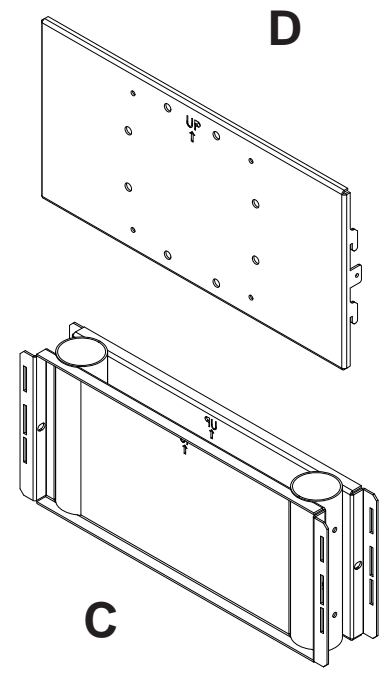

**A**



**B**

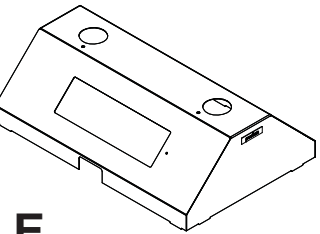
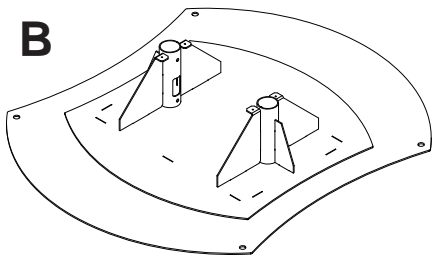

**F**

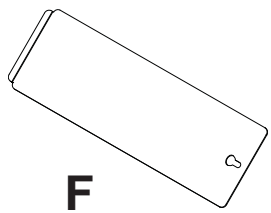

**G**

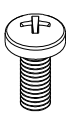
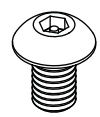

**H**

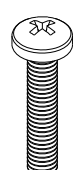

**I**

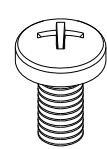

**J**

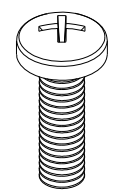

**K**

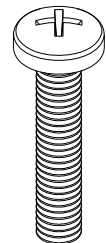

**L**

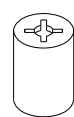

**M**

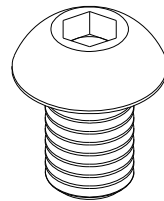

**N**

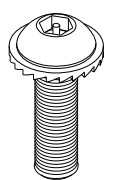

**O**

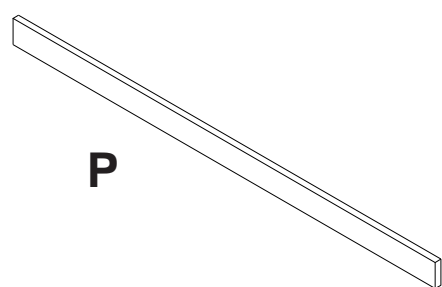

**P**



**Q**

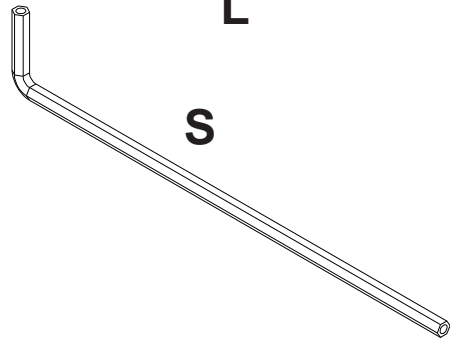

**S**

**R**

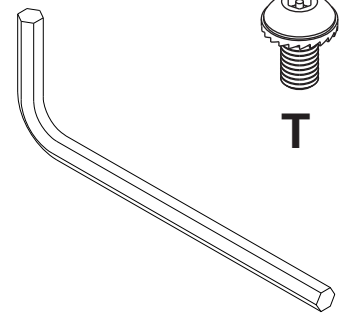

**T**

- 1 For some situations, bumper strip (P) may be required to keep base (B) level. If so, cut bumper strip (P) into five equal pieces and adhere one piece to each corner and one piece to center of bottom side of base (B).

**Note:** The pieces can also be used in other locations on the base's bottom for other situations.

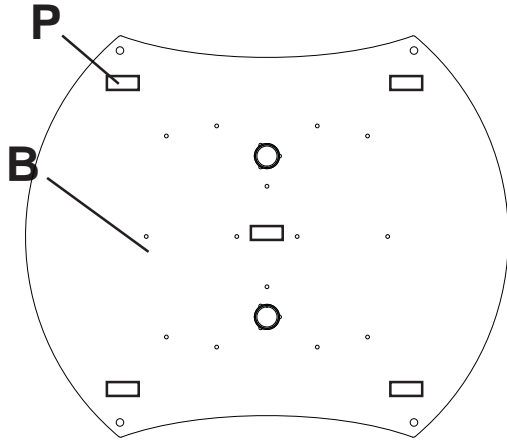

- 2 Slide two main tubes (A) onto base (B) and secure using four set screws (Q) as shown in figure 2 and detail 1. Tighten screws using 4 mm allen wrench (S).

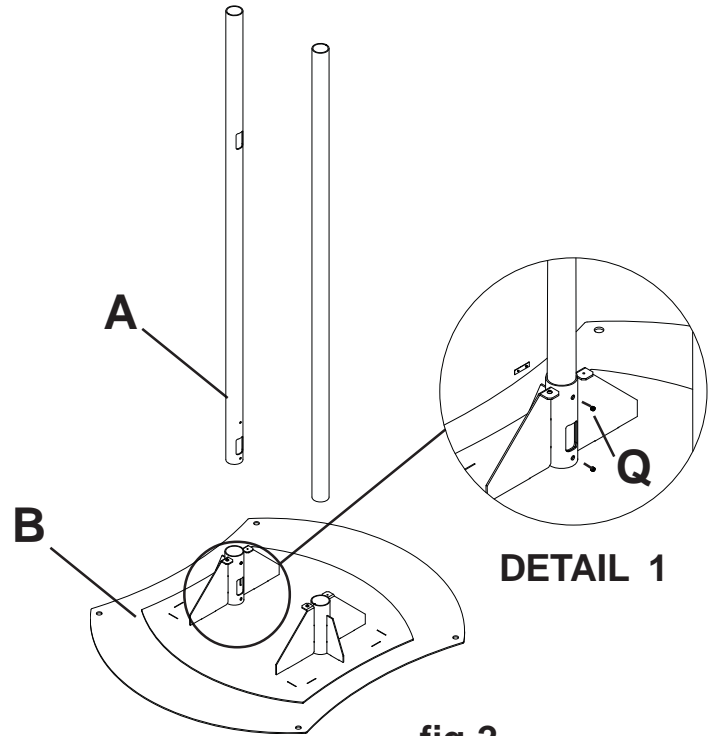

- 3 Slide base cover (E) down tubes (A) onto base (B) as shown below. Secure using two M5 x 8 mm socket pin screws (G). Tighten screws using 4 mm allen wrench (S).

**Note:** Make sure that notches on bottom of base cover fit into holes in base.

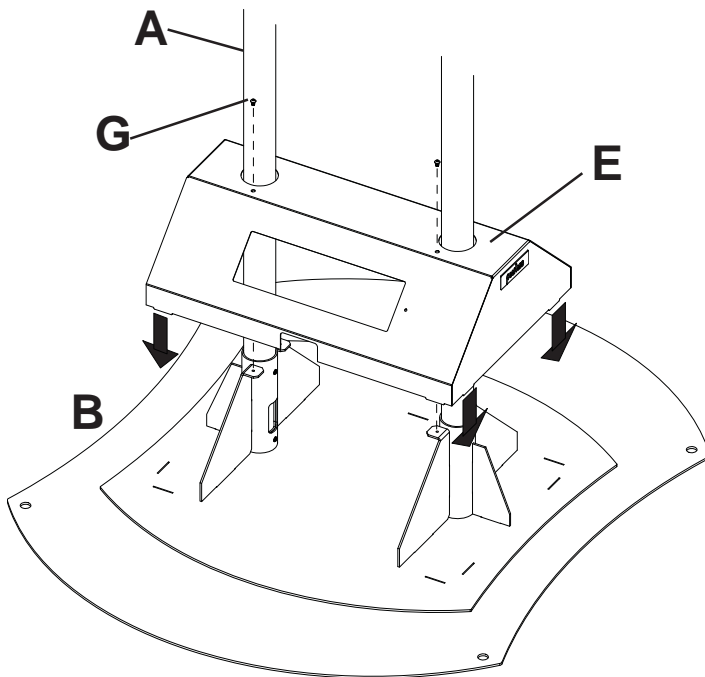

- 4 Slide cable access cover (F) into base cover (E) as shown below. Secure using socket pin serrated washer head screw (T). Tighten screws using 4mm allen wrench (S).

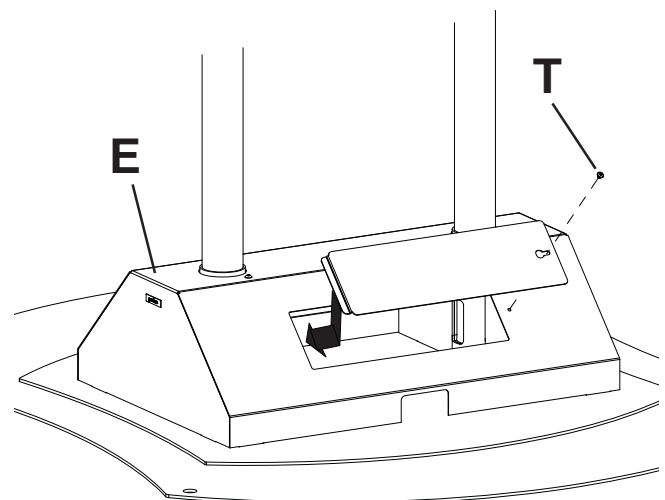

5

Slide carriage (C) onto main tubes (A). Slide carriage to desired height and secure using four set screws (Q) as shown in detail 1. Tighten screws using 4 mm allen wrench (T).

**Note:** Orientation of "UP" arrow is critical.

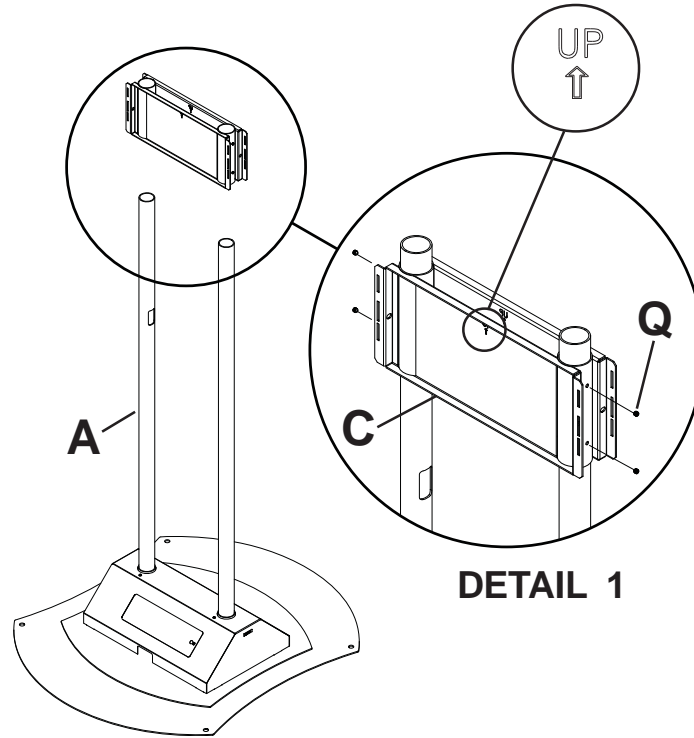

## Attaching Adapter Plate to Screen with VESA 200 x 200 Mounting Pattern

### ⚠ WARNING

- If screws don't get three complete turns in the screen inserts or if screws bottom out and bracket is still not tightly secured, damage may occur to screen or product may fail.

**6** Choose hole pattern as shown in figure 6.1. Attach adapter plate (**D**) to back of screen using four M6 x 12 mm screws (**J**) as shown.

**Note:** Orientation of "UP" arrow is critical.

**\*Note:** If screw (**J**) gets less than three threads of engagement, attach adapter plate (**D**) to back of screen using four M6 x 20 mm screws (**K**). If screw (**K**) still gets less than three threads of engagement, use four M6 x 30 mm screws (**L**).

*Skip to step 7 on page 7.*

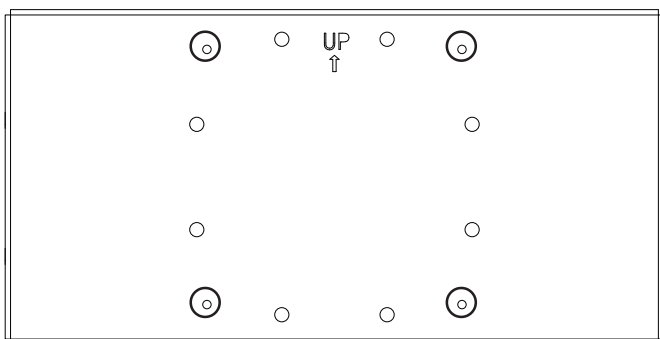
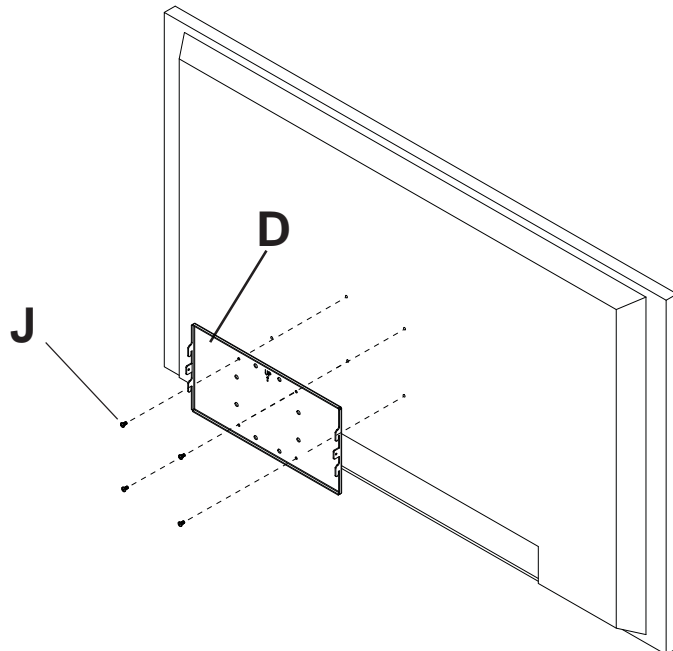

fig 6.1



## Attaching Adapter Plate to PLP Model Adapter Bracket

For screen compatibility please refer to the plasma interface list on our website [www.peerlessmounts.com](http://www.peerlessmounts.com) or call customer care for a screen specific adapter bracket (PLP models).

Note: Refer to PLP model adapter bracket instruction sheet for attachment of adapter bracket to screen.

**6** Choose hole pattern as shown in figure 6.2. Attach adapter plate (**D**) to back of screen using four M10 x 15 mm screws (**N**) as shown. Tighten screws using 6 mm allen wrench (**R**).

**Note:** Orientation of "UP" arrow is critical.

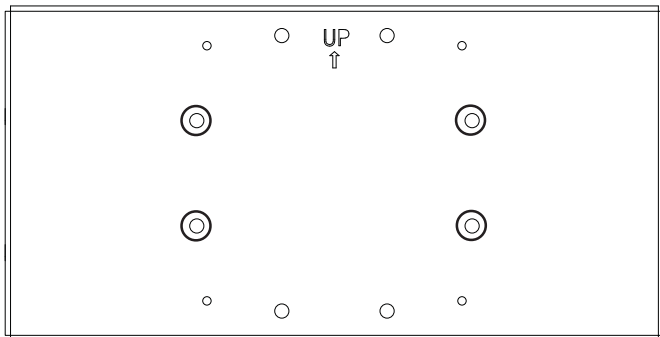
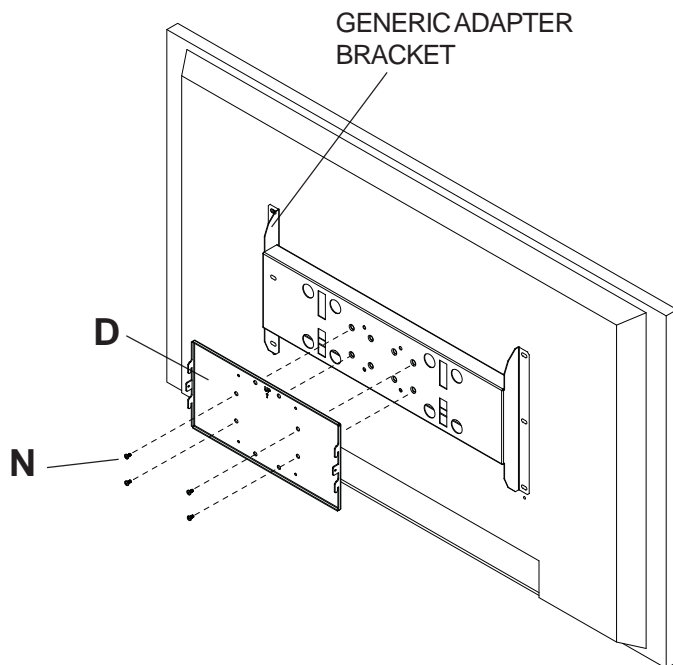

fig 6.2



## 6 Portrait orientation

Choose hole pattern as shown in figure 6.3. Attach adapter plate (D) to back of screen using four M10 x 15 mm screws (N) as shown. Tighten screws using 6 mm allen wrench (R).

**Note:** Orientation of "UP" arrow is critical.

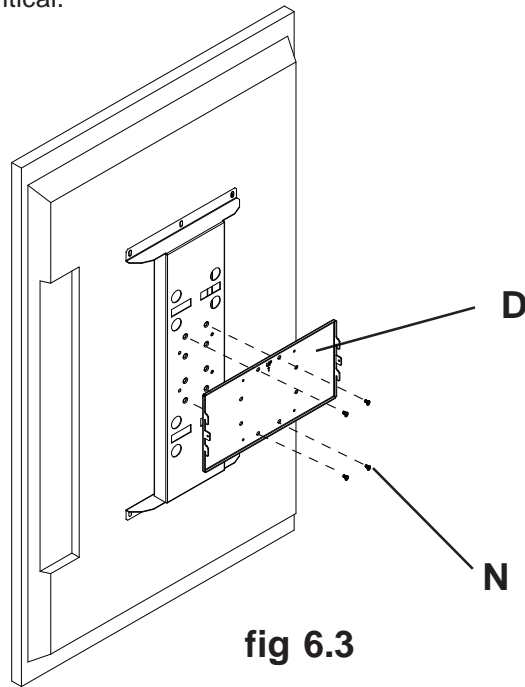

7 Hook adapter plate (D) onto carriage (C) and secure using two M6 x 20 mm serrated washer head socket pin screws (O) as shown in figure 5 and detail 3. Tighten screws using 4 mm allen wrench (S).

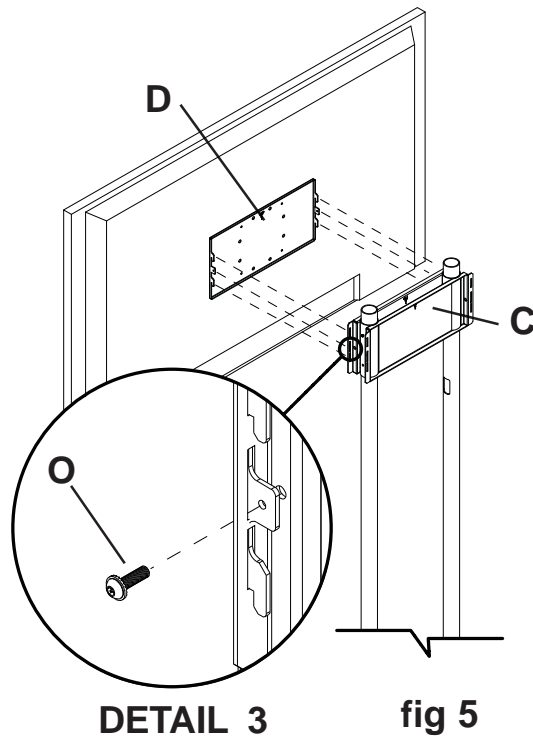

8 To install second screen, repeat steps six and seven for back side of carriage (C).