

Hybrid Pro Modular Kit 13

HP-K-13

Hybrid Pro™ Modular exhibits and counters are a perfect solution for the serious exhibitor. Exhibits feature heavy-duty aluminum extrusion frames and push-fit fabric graphics. Count on making an unforgettable impact with Hybrid Pro Modular exhibit kits, counters, and accessories.



features and benefits:

- Silver aluminum extrusion frame
- Single-sided SEG dye-sublimated push-fit fabric graphics
- UV graphic printed on 6mm white Sintra
- Easy step-by-step instructions
- Kit includes frame, four fabric graphic panels, ten Sintra infills, two counters, two 200 LED floodlights, two medium monitor mounts and one SCRATE case
- Lifetime hardware warranty against manufacturer defects

dimensions:

Hardware

Assembled unit:
232.25" w x 94.5" h x 19.63" d
5899.15mm(w) x 2400.3mm(h) x 498.6mm(d)

Counter (each):
30.63" w x 40.5" h x 18.75" d approx.
778mm(w) x 1028.7mm(h) x 476.25mm(d)

Counter (each) holds max weight:
50 lbs / 22.68 kgs

Shipping

Shipping dimensions - ships in 1 case:
1 SCRATE case: 59" l x 57" h x 34" d
1498.6mm(l) x 1447.8mm(h) x 863.6mm(d)

Approximate shipping weight (entire kit):
415 lbs / 188.25 kgs

Graphic

Total visual area:
Panels A, B, C, D, E, G, H, J, K, M, N (UV graphic panel): 12.28" w x 43.28" h
312mm(w) x 1099mm(h)

Panels C, F, I, L:
47.125" w x 94.375" h
11.97mm(w) x 2397mm(h)

Counters:
Front Wrap Panel: 73.25" w x 39.38" h
1860.55mm(w) x 1000.25mm(h)

Back Door Panel: 11.48" w x 39.38" h
291.59mm(w) x 1000.25mm(h)

Please be sure to include a 2" bleed around the perimeter.



www.camelbackdisplays.com

additional information:

Fabric material: Dye-sublimated fabric and UV printed on 6mm white Sintra

Tabletop color options:



silver black mahogany natural

Lights Included: Lumina 200 LED floodlight, straight arm and adjustable head, black finish, 19.5" from end to end

Each medium monitor bracket holds 26-40" LCD, maximum weight: 50 lbs / 22.68 kgs

*Monitors not included

We are continually improving and modifying our product range and reserve the right to vary the specifications without prior notice. All dimensions and weights quoted are approximate and we accept no responsibility for variance. E&OE. See Graphic Templates for graphic bleed specifications.

R-HP-K-13

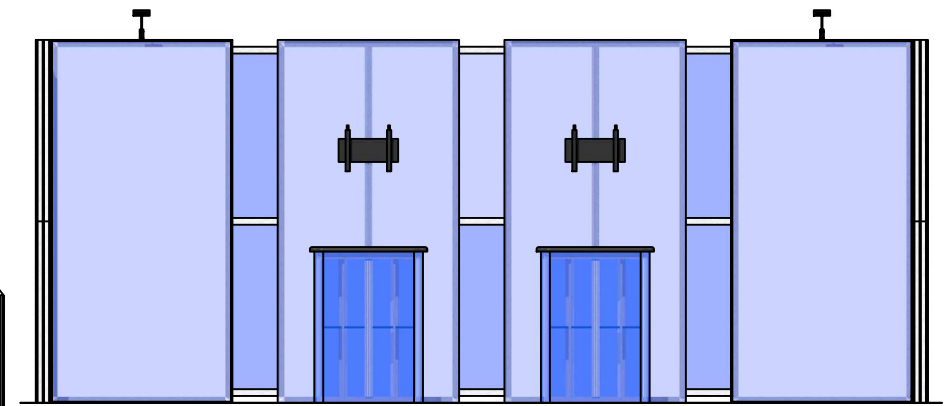
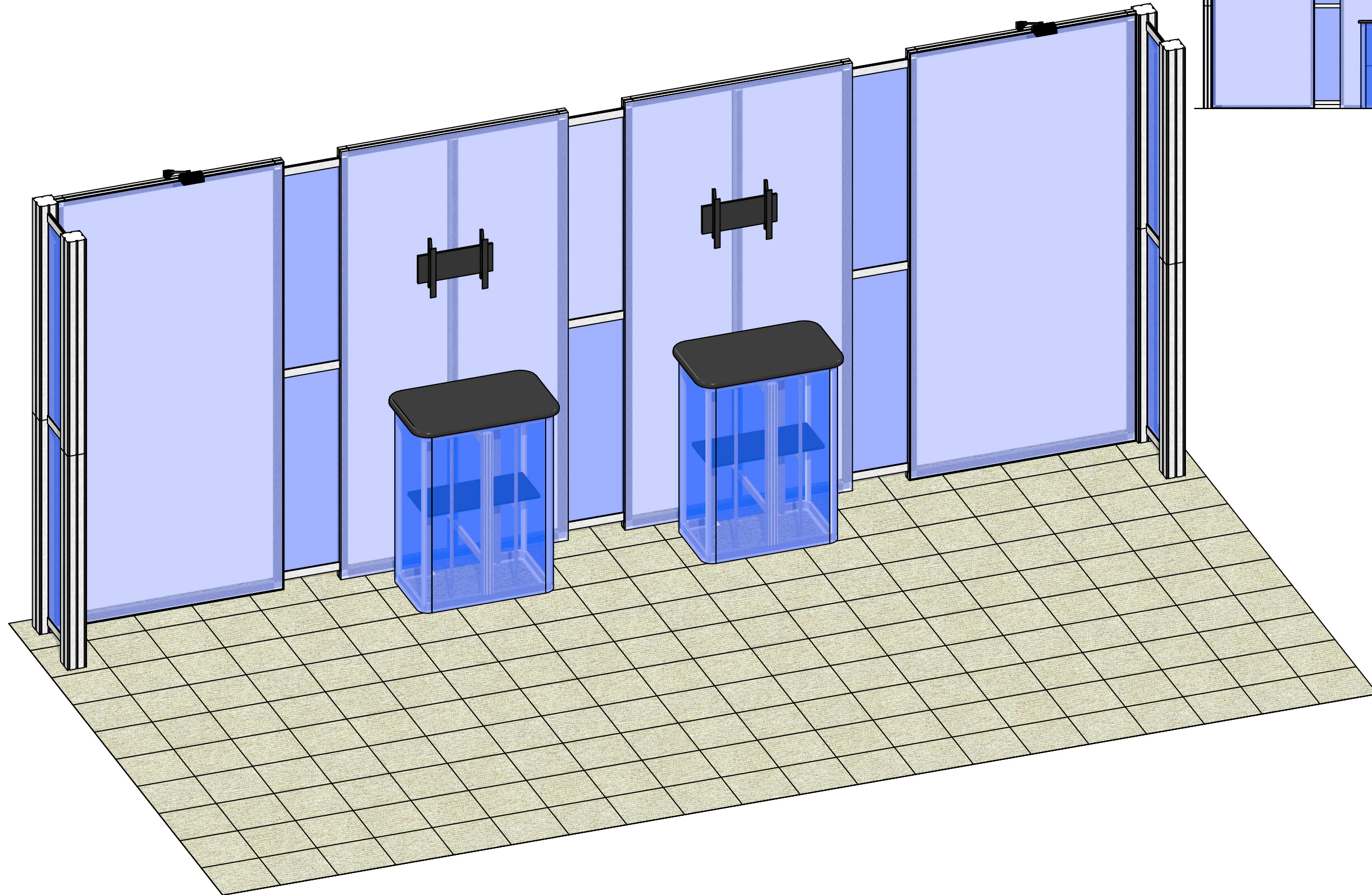

Code	#	Description
R8	15	300MM (11.81") PH EXTRUSION WITH LOCKS 2 ENDS
R37	8	1110MM (43.70") PHFC2 EXTRUSION WITH LOCKS 2 ENDS
R28	12	1155MM (45.47") PHFC2 EXTRUSION WITH IB2 HOLE ONE SIDE-WITH LOCK 1 END
GRAPHIC B2	1	94 1/2" (H) X 47 1/4" (W) SINGLE SIDED DYESUB GRAPHIC W/ FCE-2 (SEG) ON PERIMETER
LEDL10S	2	LED SPOTLIGHT,3M,UL PLUG W/TRANSFORMER SILVER
GRAPHIC C10	1	43.28"H X 12.28"W DSG GRAPHIC ON 6MM WHITE SINTRA
GRAPHIC C9	1	43.28"H X 12.28"W DSG GRAPHIC ON 6MM WHITE SINTRA
R15	8	1200MM (47.24") 100MM PM4S2 SQUARE EXTRUSION WITH PH2 STOP AT 305MM BOTH ENDS
R13	4	600MM (23.62") PM4D CONNECTOR WITH TENSION GLIDES
IB2	8	PH INLINE CONNECTOR
CB9-S	16	50MM SQUARE PHCF2 CORNER BRACKET
GRAPHIC A2	1	94 1/2" (H) X 47 1/4" (W) SINGLE SIDED DYESUB GRAPHIC W/ FCE-2 (SEG) ON PERIMETER
R19	4	1155MM (45.47") PHFC2 EXTRUSION WITH IB2 HOLE ONE SIDE-WITH LOCK 1 END WITH SIDE CAM LOCKS
MM-MB	2	MEDIUM MONITOR BRACKET FOR MONITORS 15"-40"
GRAPHIC C5	1	43.28"H X 12.28"W DSG GRAPHIC ON 6MM WHITE SINTRA
R22	4	1155MM (45.47") 50MM PM2R8 8 WAY ROUND EXTRUSION WITH STOP AT 155MM WITH LOCK 1 END
R25	2	300MM PH4 EXTRUSION WITH TENSION GLIDES FOR STACKING 50MM EXTRUSIONS
GRAPHIC B1	1	94 1/2" (H) X 47 1/4" (W) SINGLE SIDED DYESUB GRAPHIC W/ FCE-2 (SEG) ON PERIMETER
GRAPHIC A1	1	94 1/2" (H) X 47 1/4" (W) SINGLE SIDED DYESUB GRAPHIC W/ FCE-2 (SEG) ON PERIMETER
GRAPHIC C7	1	43.28"H X 12.28"W DSG GRAPHIC ON 6MM WHITE SINTRA
GRAPHIC C8	1	43.28"H X 12.28"W DSG GRAPHIC ON 6MM WHITE SINTRA
GRAPHIC C6	1	43.28"H X 12.28"W DSG GRAPHIC ON 6MM WHITE SINTRA
GRAPHIC C4	1	43.28"H X 12.28"W DSG GRAPHIC ON 6MM WHITE SINTRA
GRAPHIC C1	1	43.28"H X 12.28"W DSG GRAPHIC ON 6MM WHITE SINTRA
GRAPHIC C2	1	43.28"H X 12.28"W DSG GRAPHIC ON 6MM WHITE SINTRA
GRAPHIC C3	1	43.28"H X 12.28"W DSG GRAPHIC ON 6MM WHITE SINTRA
R63	4	432MM (17.00") PH EXTRUSION WITH LOCKS 2 ENDS

BOM

R-HP-K-13

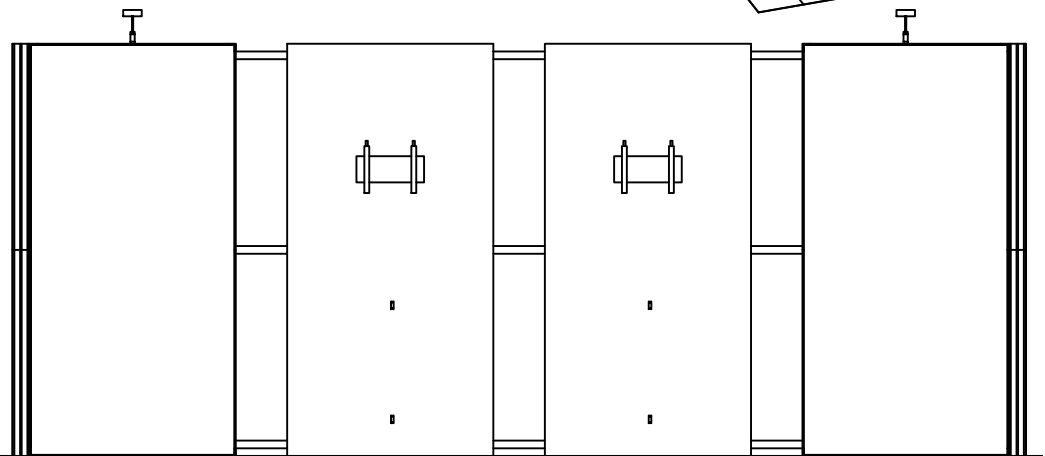
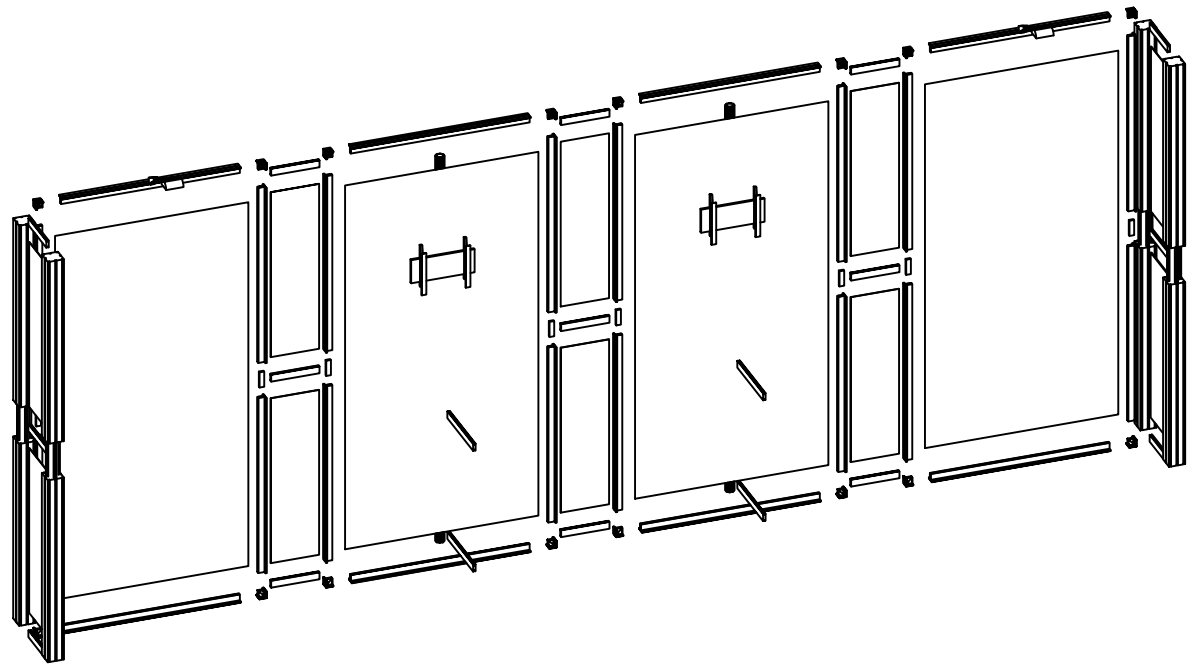
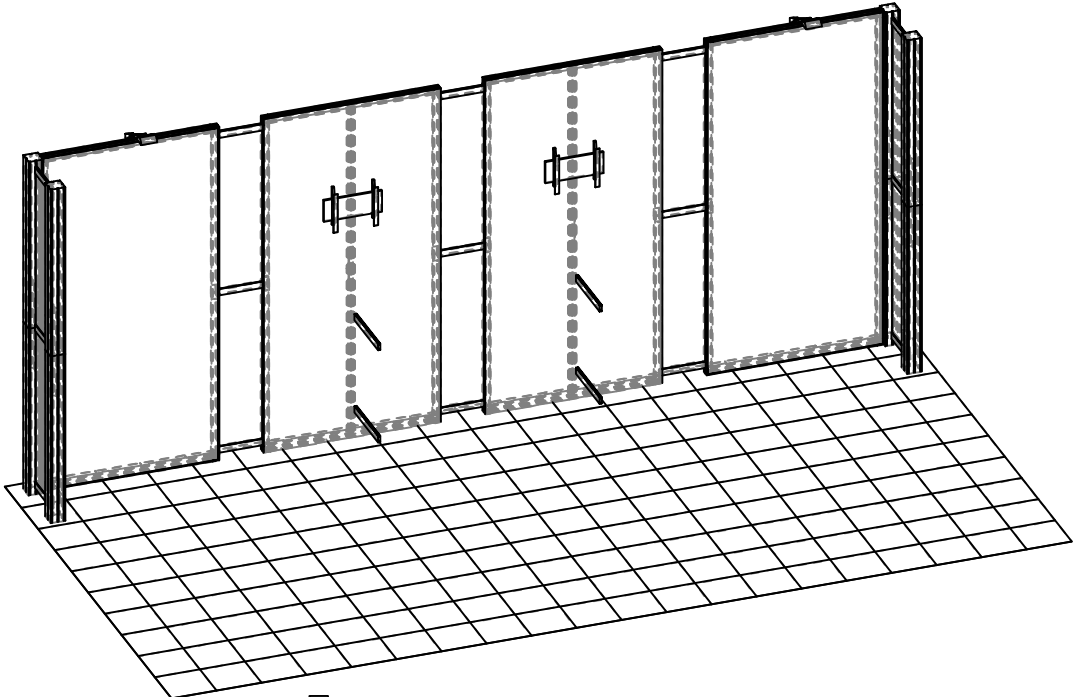
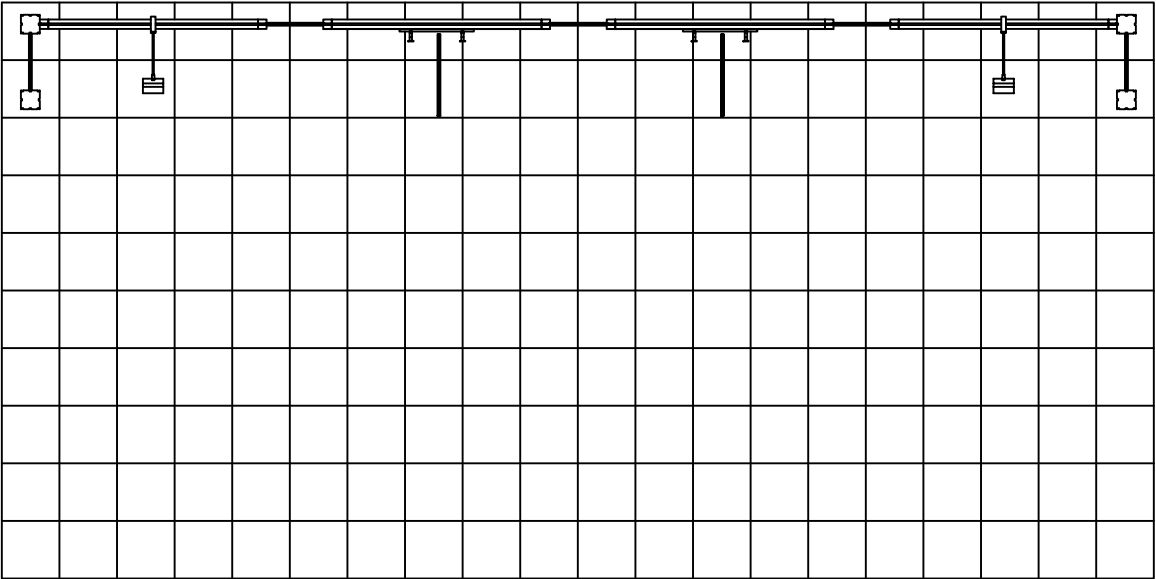

Code	#	Description
R37	4	1110MM (43.70") PHFC2 EXTRUSION WITH LOCKS 2 ENDS
R28	8	1155MM (45.47") PHFC2 EXTRUSION WITH IB2 HOLE ONE SIDE-WITH LOCK 1 END
IB2	4	PH INLINE CONNECTOR
CB9-S	8	50MM SQUARE PHCF2 CORNER BRACKET
R22	4	1155MM (45.47") 50MM PM2R8 8 WAY ROUND EXTRUSION WITH STOP AT 155MM WITH LOCK
R25	2	300MM PH4 EXTRUSION WITH TENSION GLIDES FOR STACKING 50MM EXTRUSIONS
R63	4	432MM (17.00") PH EXTRUSION WITH LOCKS 2 ENDS

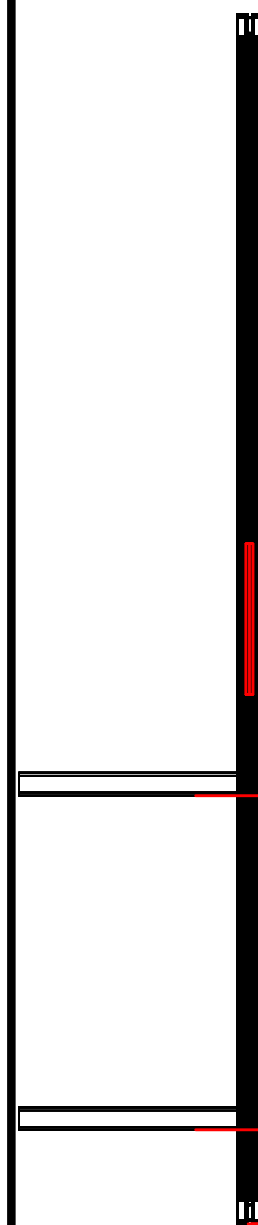
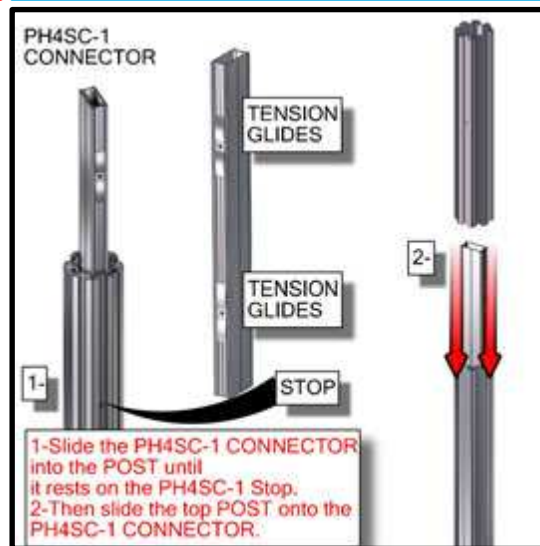
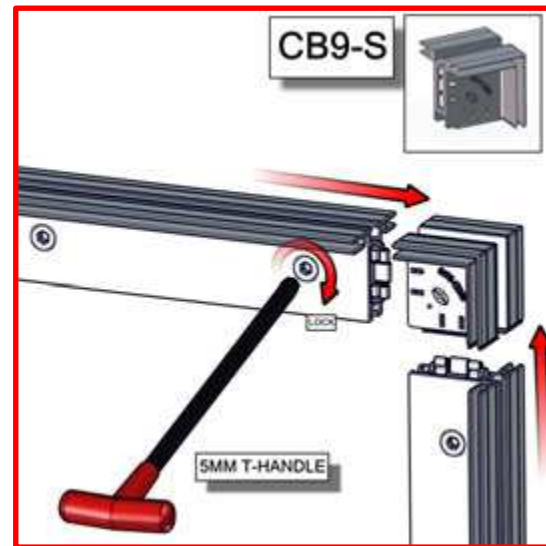

BUILD 2 UNITS

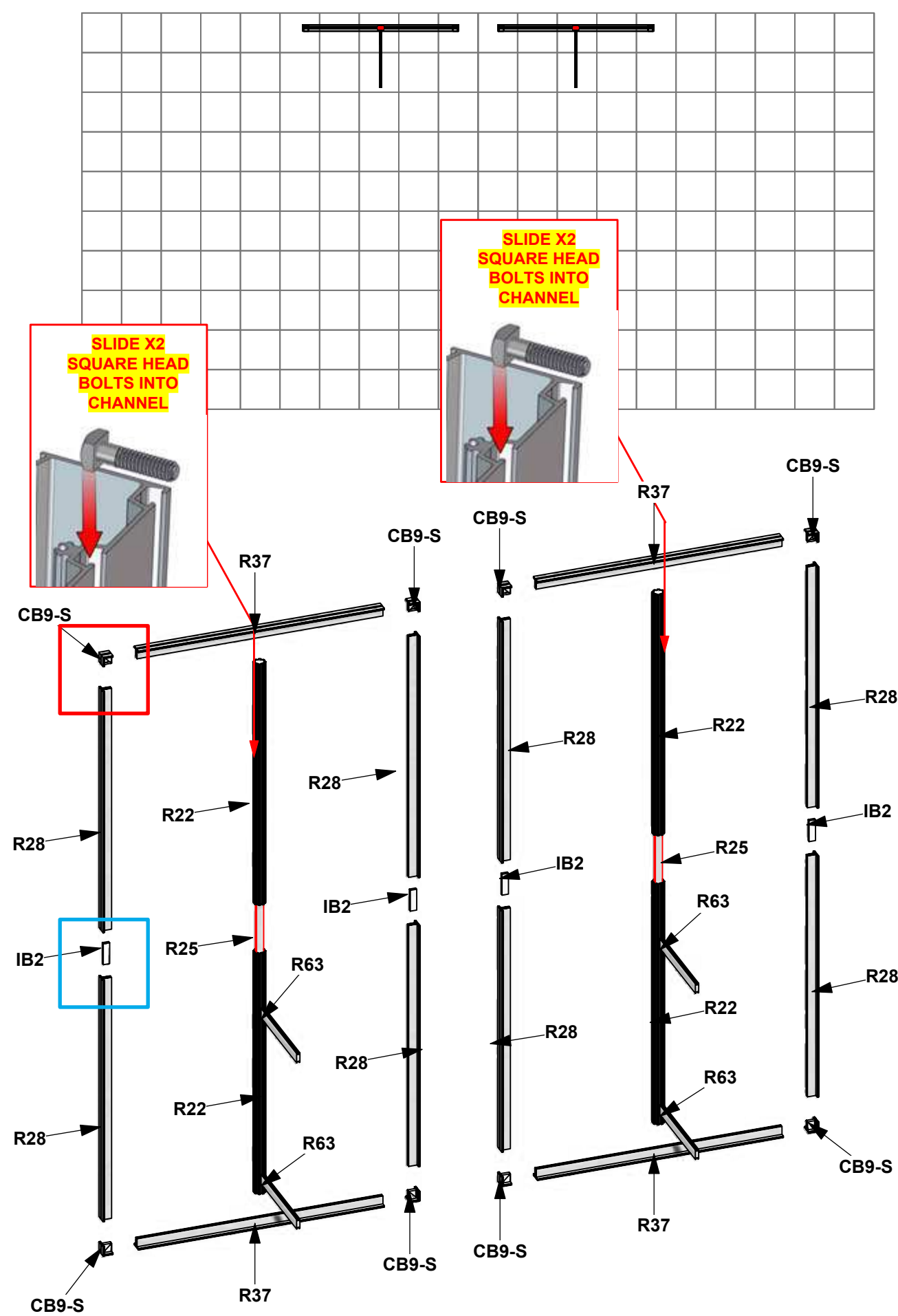

1. Redesign of this exhibit without approval by manufacturer may result in dangerous and unsafe structures. Manufacturer disclaims any responsibility for redesigned exhibits it does not approve in writing.

2. Parts and components such as panels and extrusions are manufactured to metric sizing. Where ever possible sizes have been noted in feet and inches as well as in metric. Below is the imperial to metric sizing table as reference. "Nominal" refers to approximate size.

- | | |
|--------------------|---------------------------------|
| 2400mm = (94 1/2") | Phone Line / Fax |
| 2100mm = (82 5/8") | Internet connection |
| 1800mm = (70 7/8") | Outlet |
| 1500mm = (59") | Main Drop (point of distrution) |
| 1200mm = (47 1/4") | |
| 900mm = (35 1/2") | |
| 600mm = (23 5/8") | |
| 300mm = (11 7/8") | |
- Wire running under carpet

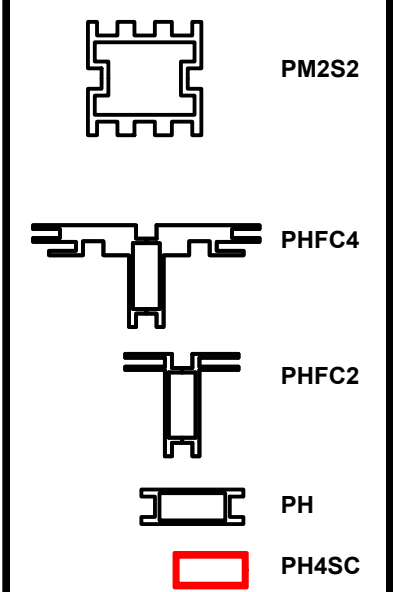

HYBRID PRO RENTAL KIT

Title: SET-UP INSTRUCTIONS

Code	#	Description
R37	4	1110MM (43.70") PHFC2 EXTRUSION WITH LOCKS 2 ENDS
R28	4	1155MM (45.47") PHFC2 EXTRUSION WITH IB2 HOLE ONE SIDE-WITH LOCK 1 END
R19	4	1155MM (45.47") PHFC2 EXTRUSION WITH IB2 HOLE ONE SIDE-WITH LOCK 1 END W/
IB2	4	PH INLINE CONNECTOR
CB9-S	8	50MM SQUARE PHCF2 CORNER BRACKET

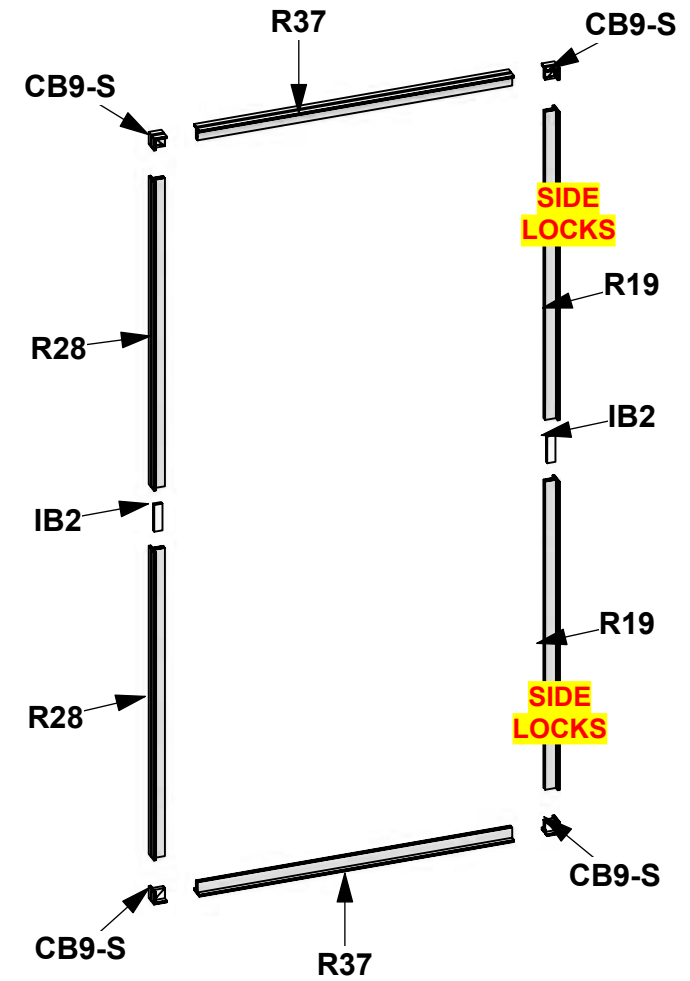
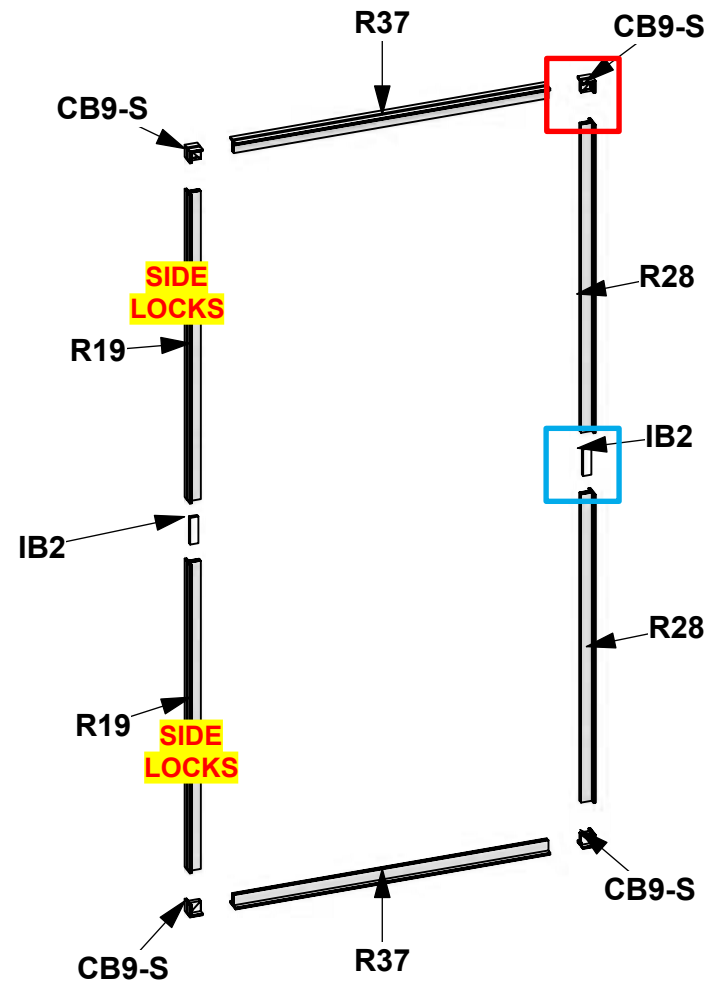

1. Redesign of this exhibit without approval by manufacturer may result in dangerous and unsafe structures. Manufacturer disclaims any responsibility for redesigned exhibits it does not approve in writing.

2. Parts and components such as panels and extrusions are manufactured to metric sizing. Where ever possible sizes have been noted in feet and inches as well as in metric. Below is the imperial to metric sizing table as reference. "Nominal" refers to approximate size.

2400mm = (94 1/2")	Phone Line / Fax
2100mm = (82 5/8")	Internet connection
1800mm = (70 7/8")	Outlet
1500mm = (59")	Main Drop (point of distrution)
1200mm = (47 1/4")	
900mm = (35 1/2")	
600mm = (23 5/8")	
300mm = (11 7/8")	

--- Wire running under carpet

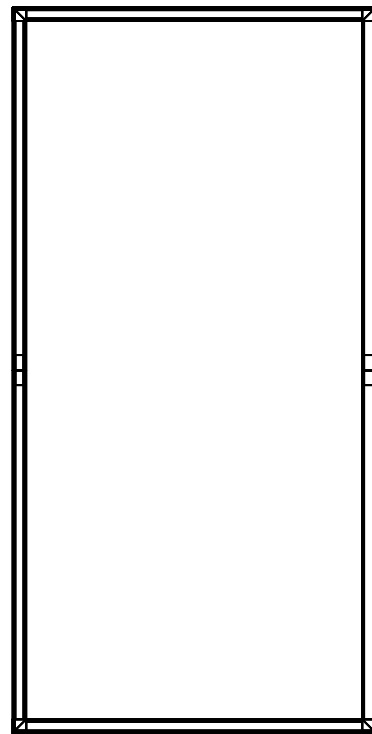
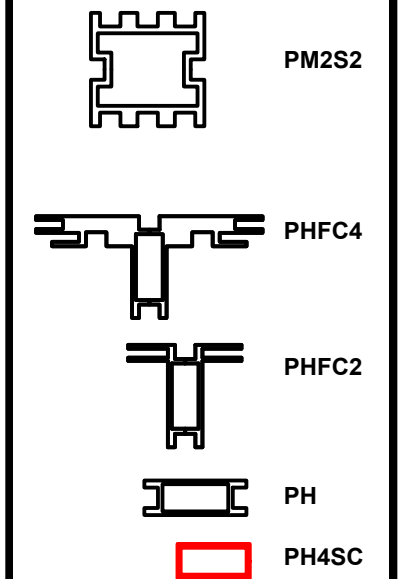

BUILD 2 UNITS

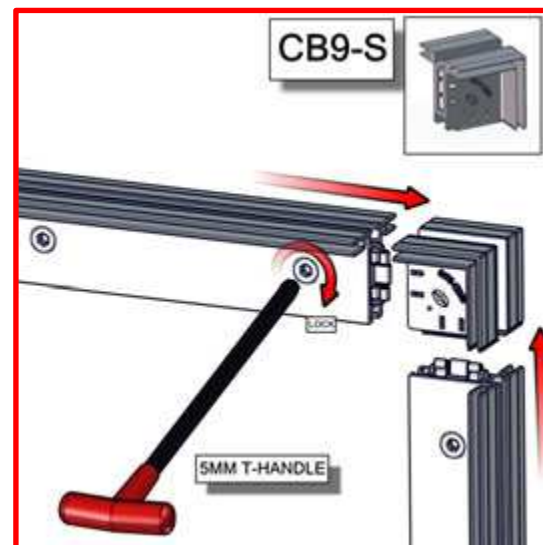

HYBRID PRO RENTAL KIT

Title: SET-UP INSTRUCTIONS

Code	#	Description
R8	11	300MM (11.81") PH EXTRUSION WITH LOCKS 2 ENDS
R15	8	1200MM (47.24") 100MM PM4S2 SQUARE EXTRUSION WITH PH2 STOP AT 305M
R13	4	600MM (23.62") PM4D CONNECTOR WITH TENSION GLIDES
GRAPHIC C5	1	43.28"H X 12.28"W DSG GRAPHIC ON 6MM WHITE SINTRA
GRAPHIC C7	1	43.28"H X 12.28"W DSG GRAPHIC ON 6MM WHITE SINTRA
GRAPHIC C8	1	43.28"H X 12.28"W DSG GRAPHIC ON 6MM WHITE SINTRA
GRAPHIC C6	1 </td <td>43.28"H X 12.28"W DSG GRAPHIC ON 6MM WHITE SINTRA</td>	43.28"H X 12.28"W DSG GRAPHIC ON 6MM WHITE SINTRA
GRAPHIC C4	1	43.28"H X 12.28"W DSG GRAPHIC ON 6MM WHITE SINTRA
GRAPHIC C3	1	43.28"H X 12.28"W DSG GRAPHIC ON 6MM WHITE SINTRA

1. Redesign of this exhibit without approval by manufacturer may result in dangerous and unsafe structures. Manufacturer disclaims any responsibility for redesigned exhibits it does not approve in writing.

2. Parts and components such as panels and extrusions are manufactured to metric sizing. Where ever possible sizes have been noted in feet and inches as well as in metric. Below is the imperial to metric sizing table as reference. "Nominal" refers to approximate size.

2400mm = (94 1/2")	Phone Line / Fax
2100mm = (82 5/8")	Internet connection
1800mm = (70 7/8")	Outlet
1500mm = (59")	Main Drop (point of distrution)
1200mm = (47 1/4")	
900mm = (35 1/2")	
600mm = (23 5/8")	
300mm = (11 7/8")	

--- Wire running under carpet

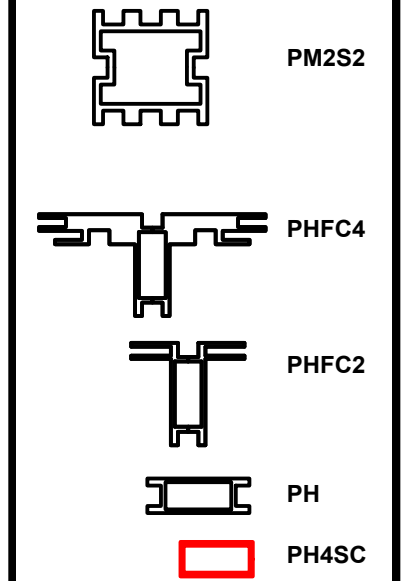
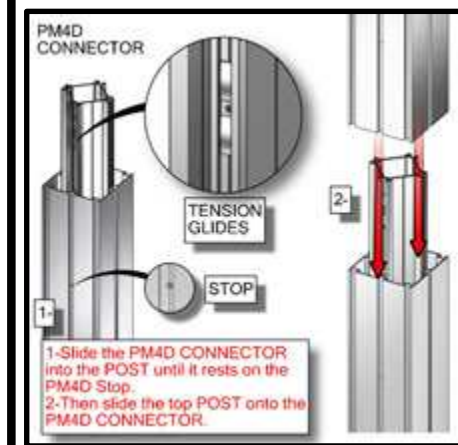
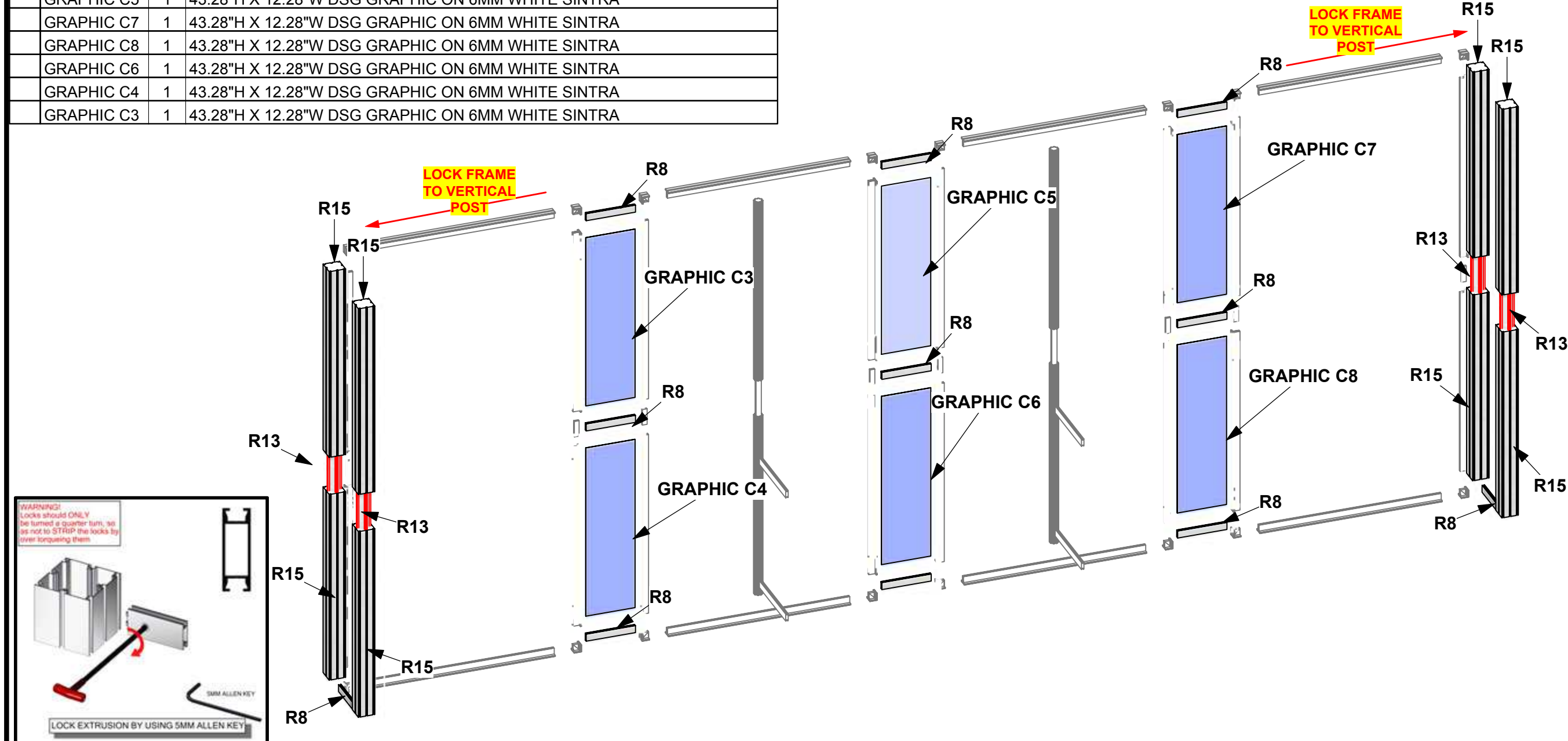

HYBRID PRO RENTAL KIT

Title: SET-UP INSTRUCTIONS

Code	#	Description
R8	4	300MM (11.81") PH EXTRUSION WITH LOCKS 2 ENDS
GRAPHIC C10	1	43.28"H X 12.28"W DSG GRAPHIC ON 6MM WHITE SINTRA
GRAPHIC C9	1	43.28"H X 12.28"W DSG GRAPHIC ON 6MM WHITE SINTRA
GRAPHIC C1	1	43.28"H X 12.28"W DSG GRAPHIC ON 6MM WHITE SINTRA
GRAPHIC C2	1	43.28"H X 12.28"W DSG GRAPHIC ON 6MM WHITE SINTRA

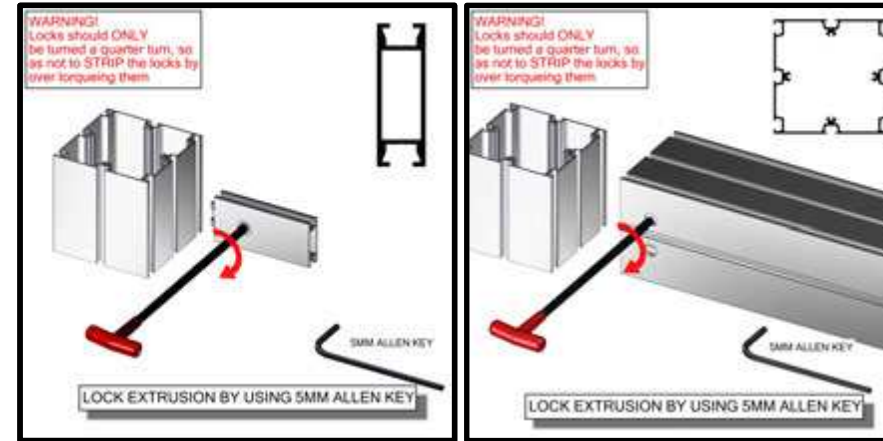

1. Redesign of this exhibit without approval by manufacturer may result in dangerous and unsafe structures. Manufacturer disclaims any responsibility for redesigned exhibits it does not approve in writing.

2. Parts and components such as panels and extrusions are manufactured to metric sizing. Where ever possible sizes have been noted in feet and inches as well as in metric. Below is the imperial to metric sizing table as reference. "Nominal" refers to approximate size.

2400mm = (94 1/2")	☒ Phone Line / Fax
2100mm = (82 5/8")	☒ Internet connection
1800mm = (70 7/8")	☒ Outlet
1500mm = (59")	☒ Main Drop (point of distrution)
1200mm = (47 1/4")	
900mm = (35 1/2")	
600mm = (23 5/8")	
300mm = (11 7/8")	

--- Wire running under carpet

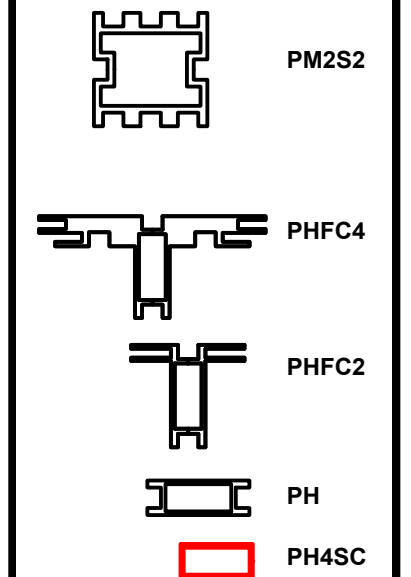
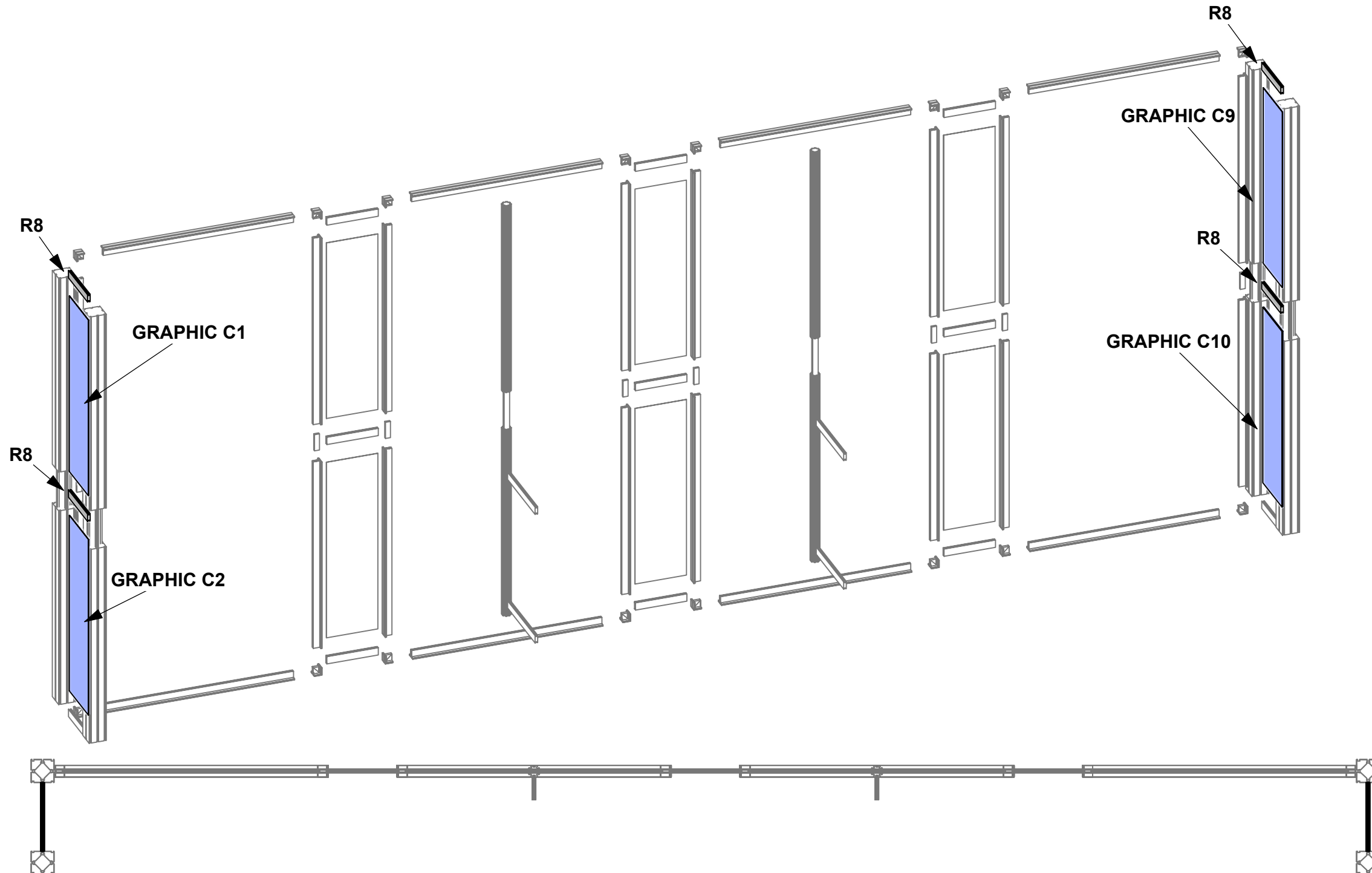

HYBRID PRO RENTAL KIT

Title: SET-UP INSTRUCTIONS

Code	#	Description
GRAPHIC B2	1	94 1/2" (H) X 47 1/4" (W) SINGLE SIDED DYESUB GRAPHIC W/ FCE-2 (SEG) ON PE
GRAPHIC A2	1	94 1/2" (H) X 47 1/4" (W) SINGLE SIDED DYESUB GRAPHIC W/ FCE-2 (SEG) ON PE
MM-MB	2	MEDIUM MONITOR BRACKET FOR MONITORS 15"-40"
GRAPHIC B1	1	94 1/2" (H) X 47 1/4" (W) SINGLE SIDED DYESUB GRAPHIC W/ FCE-2 (SEG) ON PE
GRAPHIC A1	1	94 1/2" (H) X 47 1/4" (W) SINGLE SIDED DYESUB GRAPHIC W/ FCE-2 (SEG) ON PE

MM-MB

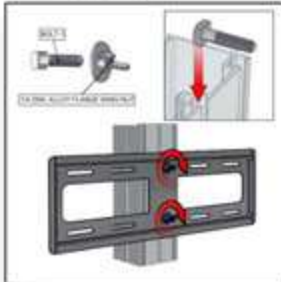
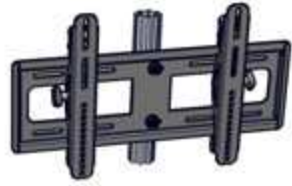

1- INSERT BOLTS INTO MIDDLE CHANNEL. THEN SECURE MONITOR MOUNT WITH WING NUTS.



2- ATTACH MONITOR TO BRACKETS SEE SANUS MANUAL FOR MORE INFO

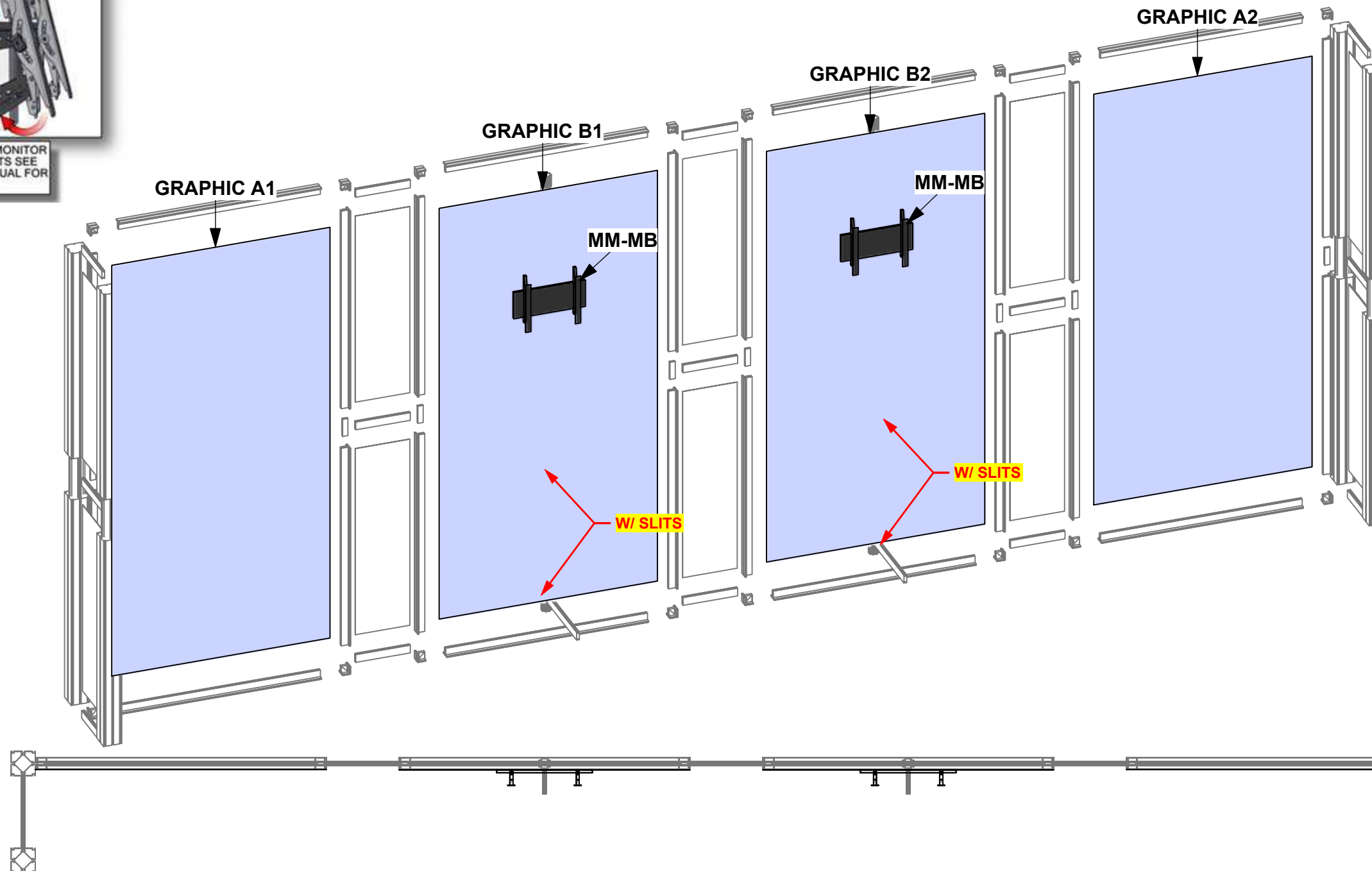
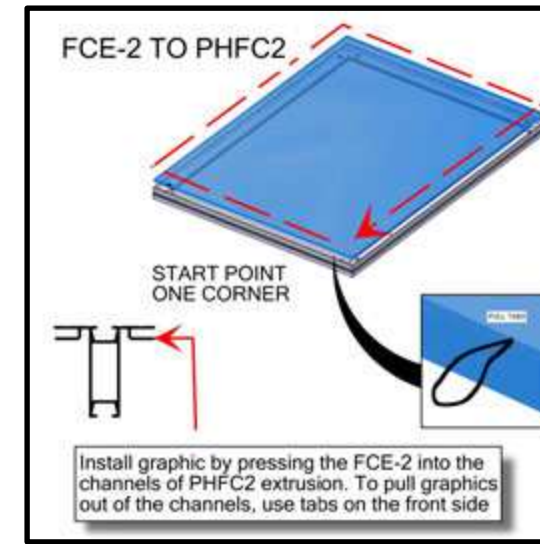
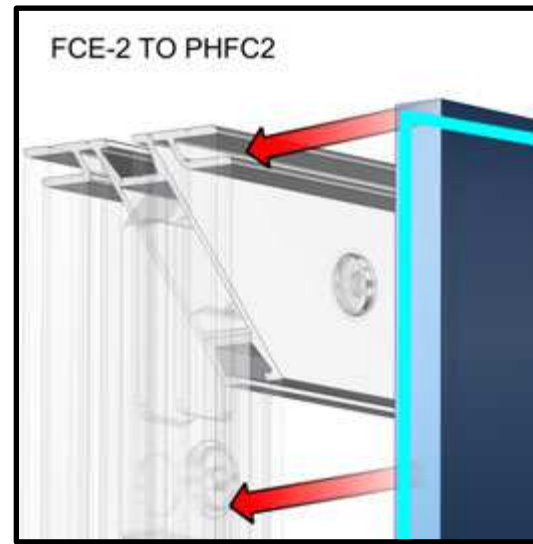

1. Redesign of this exhibit without approval by manufacturer may result in dangerous and unsafe structures. Manufacturer disclaims any responsibility for redesigned exhibits it does not approve in writing.

2. Parts and components such as panels and extrusions are manufactured to metric sizing. Where ever possible sizes have been noted in feet and inches as well as in metric. Below is the imperial to metric sizing table as reference. "Nominal" refers to approximate size.

2400mm = (94 1/2")	▼ Phone Line / Fax
2100mm = (82 5/8")	▼ Internet connection
1800mm = (70 7/8")	▼ Outlet
1500mm = (59")	▼ Main Drop (point of distrution)
1200mm = (47 1/4")	
900mm = (35 1/2")	
600mm = (23 5/8")	
300mm = (11 7/8")	

--- Wire running under carpet

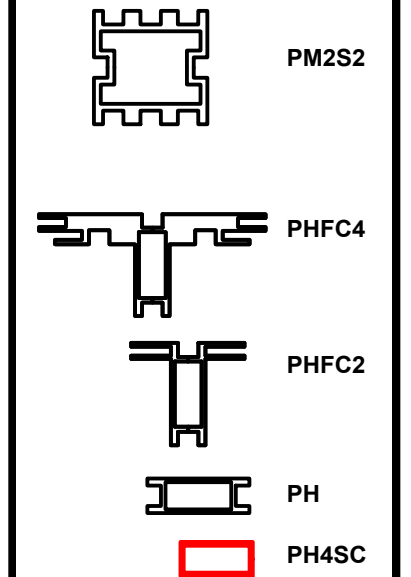

HYBRID PRO RENTAL KIT

Title: SET-UP INSTRUCTIONS

Code	#	Description
LEDL10S	2	LED SPOTLIGHT,3M,UL PLUG W/TRANSFORMER SILVER

1. Redesign of this exhibit without approval by manufacturer may result in dangerous and unsafe structures. Manufacturer disclaims any responsibility for redesigned exhibits it does not approve in writing.

2. Parts and components such as panels and extrusions are manufactured to metric sizing. Where ever possible sizes have been noted in feet and inches as well as in metric. Below is the imperial to metric sizing table as reference. "Nominal" refers to approximate size.

2400mm = (94 1/2")	Phone Line / Fax
2100mm = (82 5/8")	Internet connection
1800mm = (70 7/8")	Outlet
1500mm = (59")	Main Drop (point of distrution)
1200mm = (47 1/4")	
900mm = (35 1/2")	
600mm = (23 5/8")	
300mm = (11 7/8")	

--- Wire running under carpet

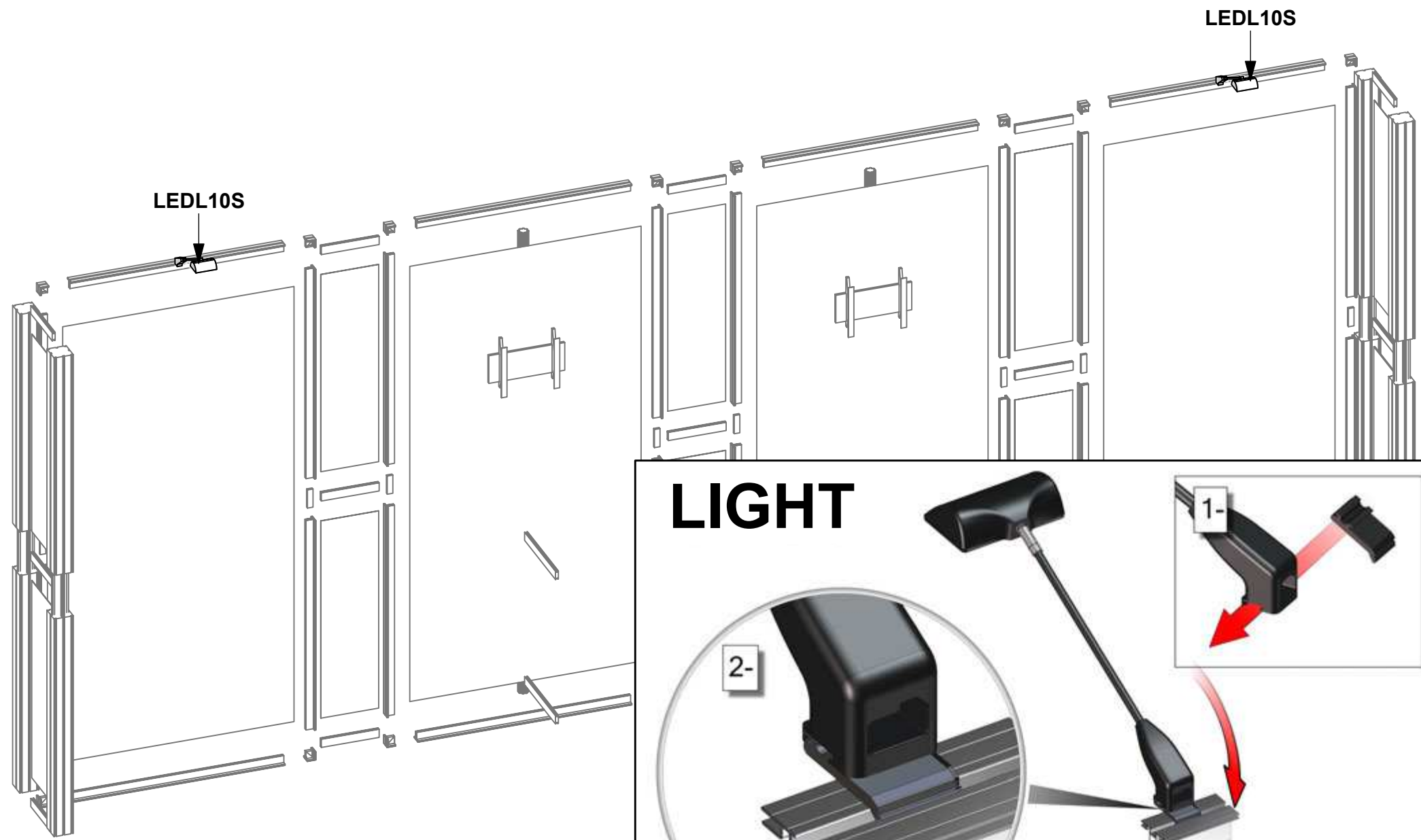

LIGHT

2-

1-

PHFC2

1- Slide light clip onto the LIGHT.
 2-Then slide the LIGHT into the channel at an angle and then gently lower down.

- PM2S2
- PHFC4
- PHFC2
- PH
- PH4SC

HYBRID PRO RENTAL KIT

Title: SET-UP INSTRUCTIONS

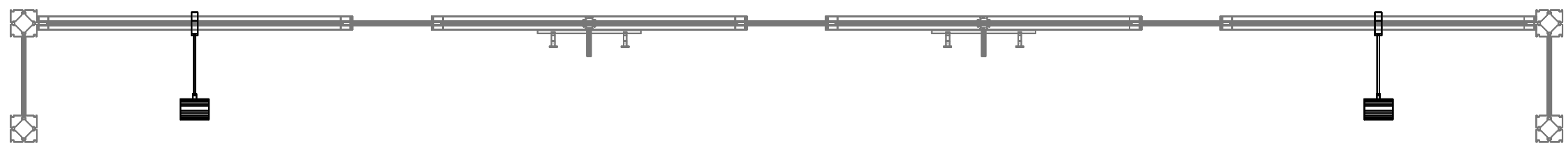

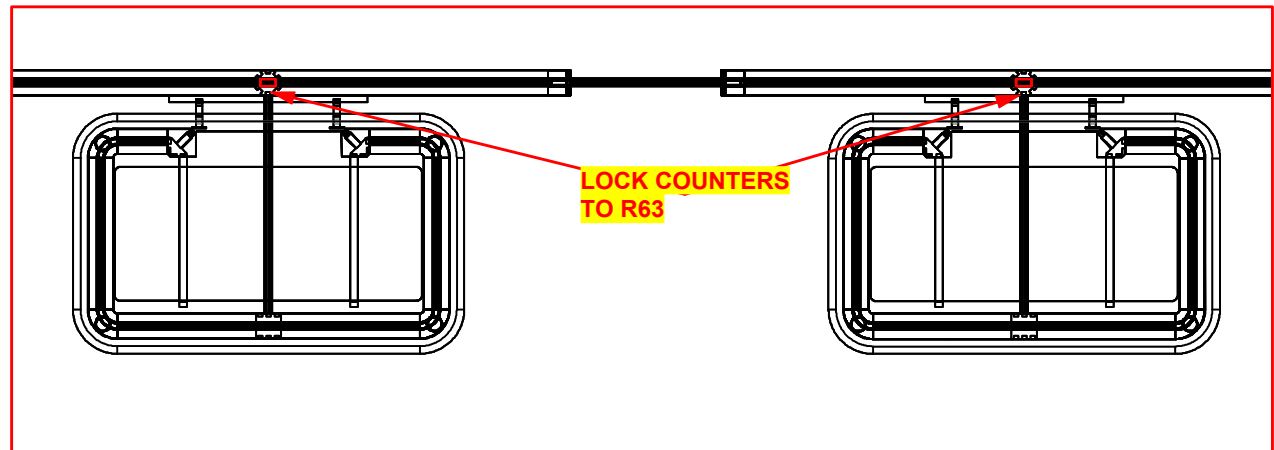
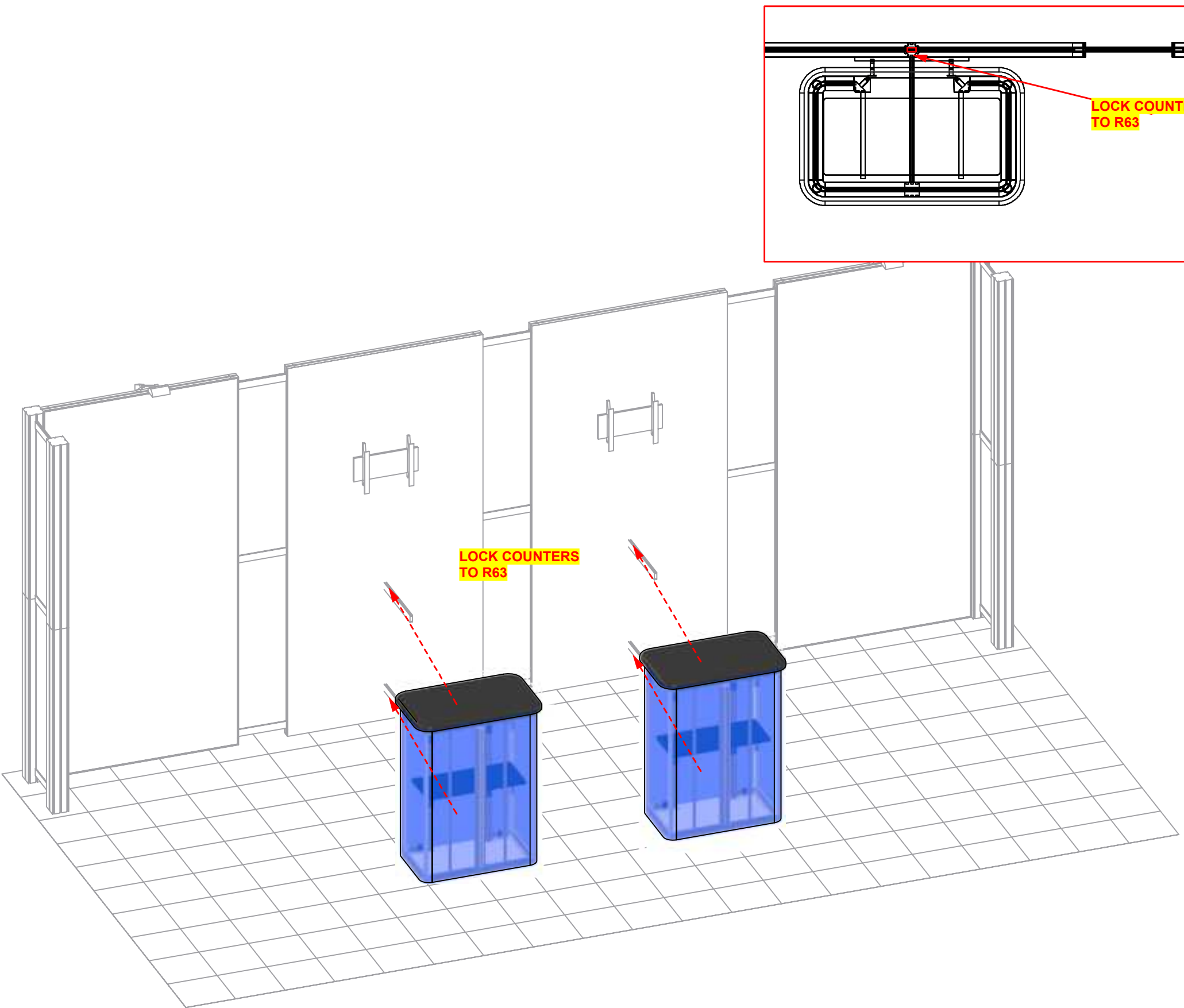

1. Redesign of this exhibit without approval by manufacturer may result in dangerous and unsafe structures. Manufacturer disclaims any responsibility for redesigned exhibits it does not approve in writing.

2. Parts and components such as panels and extrusions are manufactured to metric sizing. Where ever possible sizes have been noted in feet and inches as well as in metric. Below is the imperial to metric sizing table as reference. "Nominal" refers to approximate size.

- 2400mm = (94 1/2")
- 2100mm = (82 5/8")
- 1800mm = (70 7/8")
- 1500mm = (59")
- 1200mm = (47 1/4")
- 900mm = (35 1/2")
- 600mm = (23 5/8")
- 300mm = (11 7/8")

- Phone Line / Fax
- Internet connection
- Outlet
- Main Drop (point of distrution)

--- Wire running under carpet

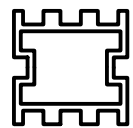

PM2S2

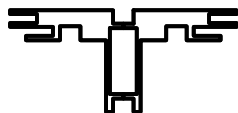

PHFC4

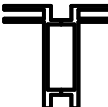

PHFC2



PH



PH4SC

HYBRID PRO RENTAL KIT

Title: SET-UP INSTRUCTIONS

R-VFC-04
W / BACKWALL

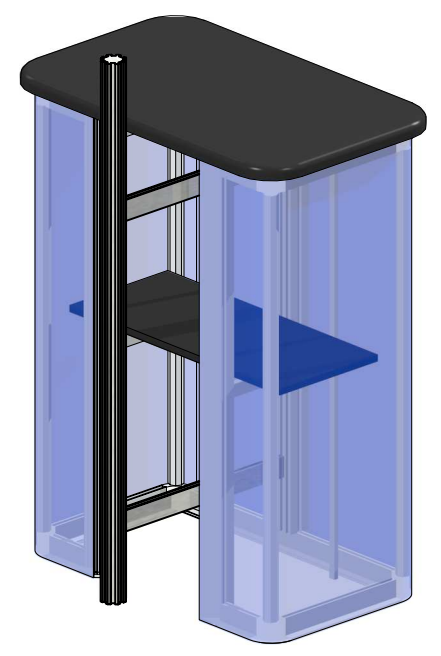
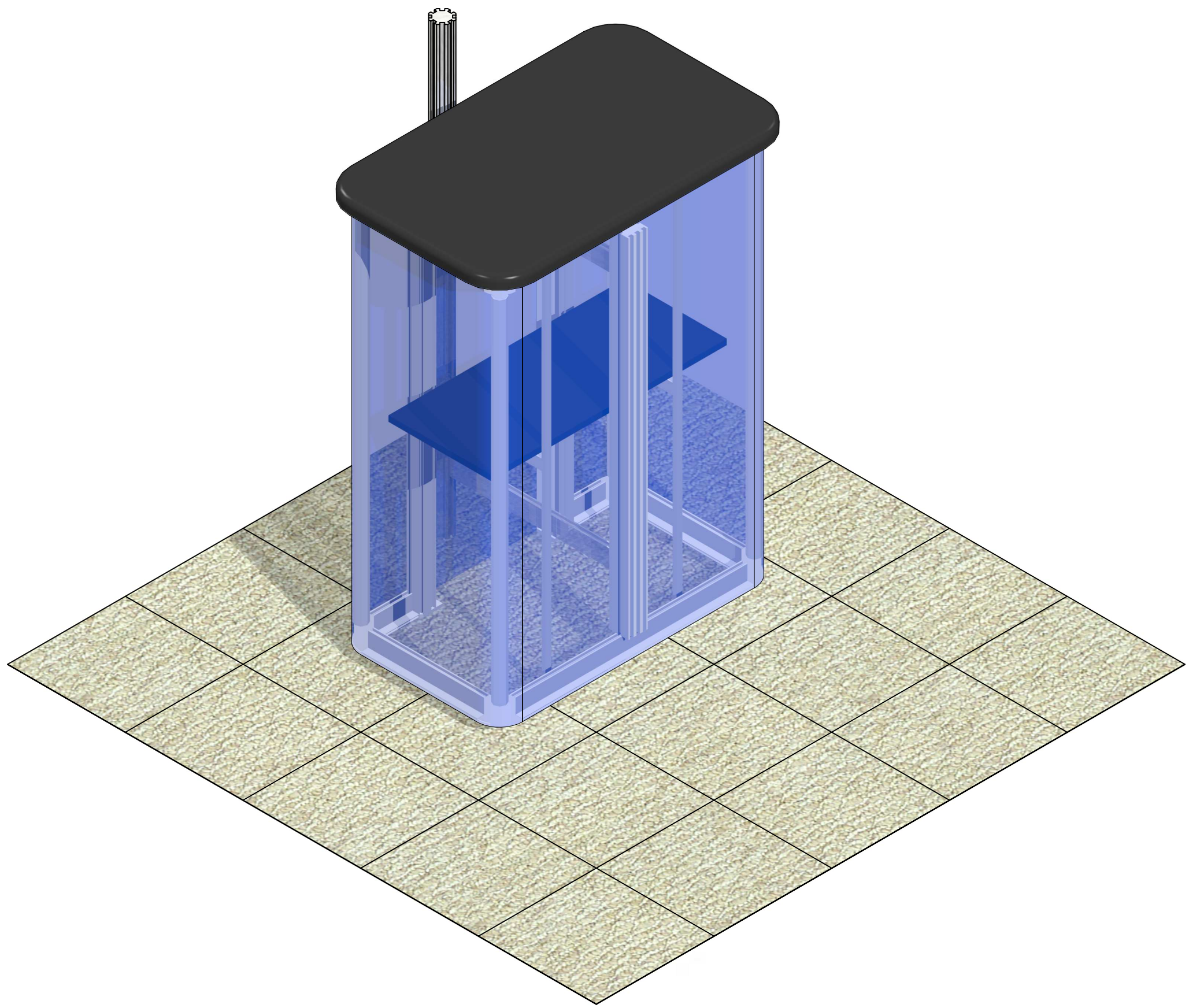

Code	#	Description
GRAPHIC	1	43 3/8" (H) X 15 1/2" (W) SINGLE SIDED DYESUB GRAPHIC W/ FCE-2 (SEG) ON PERIMETER
R6	4	300MM (11.81") PHFC2 EXTRUSION WITH LOCKS 2 ENDS
R5	4	100MM (3.94") PHFC2 EXTRUSION WITH LOCKS 2 ENDS
R109	4	910MM LENGTH 30mm (1.18 Inch) TUBE
R4	2	600MM (23.62") PHFC2 EXTRUSION WITH LOCKS 2 ENDS
VFC-04-CT	1	3' X 2' LAMINATE COUNTER TOP [BLACK THERMAFORM]
R3	2	986MM (38.82") PMFC2-90 EXTRUSION-WITH LOCKS BOTH ENDS
PMFC2-90 CAP	4	PMFC2 90 DEGREE EXTRUSION CAP
R2	4	288MM (11.34") PH1 EXTRUSION WITH LOCKS 2 ENDS
R1	1	910MM (35.82") 50MM PM2S SQUARE EXTRUSION WITH LOCKS 2 ENDS
VFC-04-CT-S	1	INTERNAL SHELF FOR VECTOR COUNTER VFC-04
GRAPHIC	1	43 3/8" (H) X 77 1/4" (W) SINGLE SIDED DYESUB GRAPHIC W/ FCE-2 (SEG) ON PERIMETER
PE-1000	2	1000MM (39.37") PE EXTRUSION
CB10-R	8	50MM ROUND PHCF2 CORNER BRACKET

R-VFC-04

BOM

BACKWALL
NOT INCLUDED

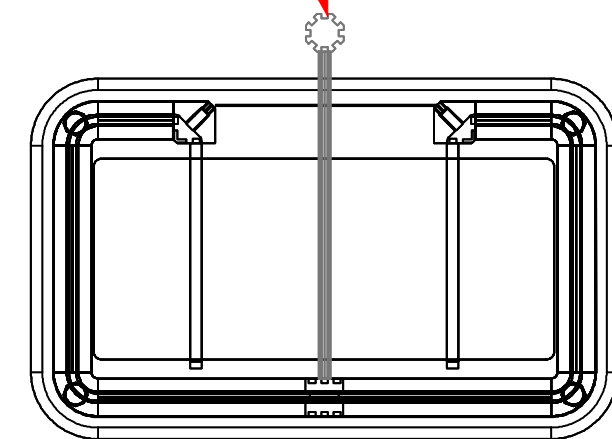

BACKWALL
NOT INCLUDED

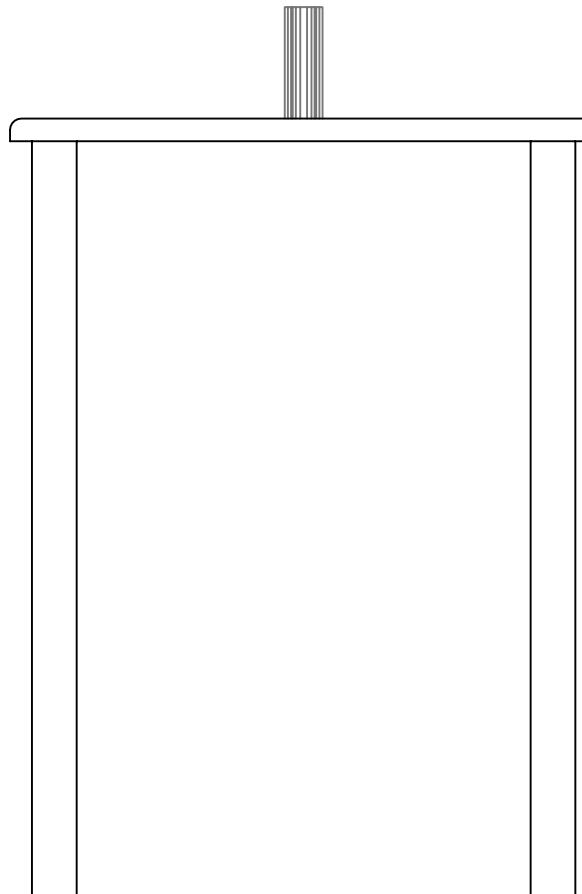
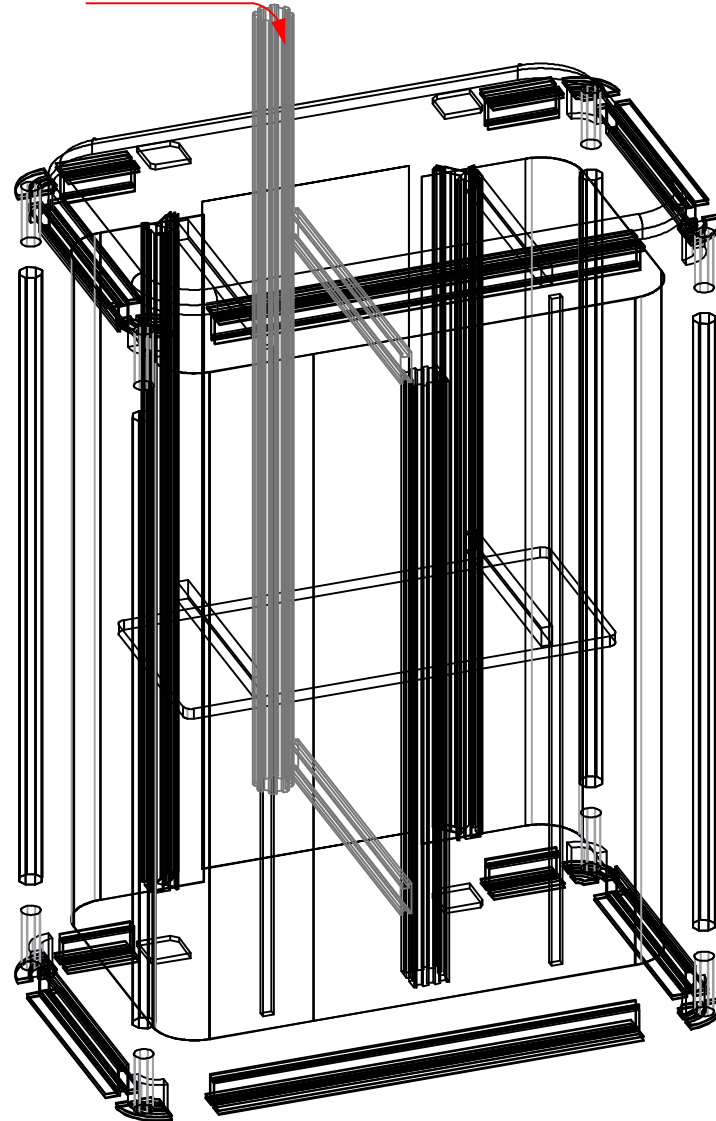

BACKWALL
NOT INCLUDED

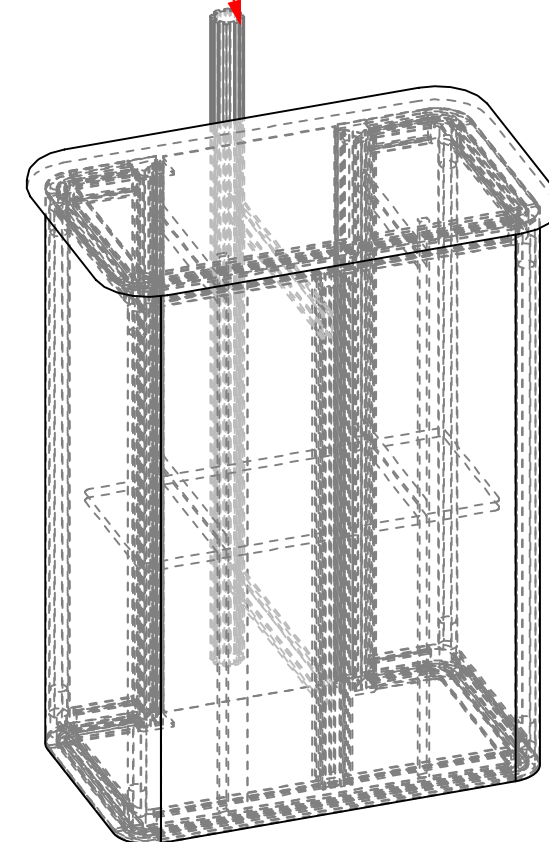

Code	#	Description
R6	4	300MM (11.81") PHFC2 EXTRUSION WITH LOCKS 2 ENDS
R109	4	910MM LENGTH 30mm (1.18 Inch) TUBE
CB10-R	8	50MM ROUND PHCF2 CORNER BRACKET

1. Redesign of this exhibit without approval by manufacturer may result in dangerous and unsafe structures. Manufacturer disclaims any responsibility for redesigned exhibits it does not approve in writing.

2. Parts and components such as panels and extrusions are manufactured to metric sizing. Where ever possible sizes have been noted in feet and inches as well as in metric. Below is the imperial to metric sizing table as reference. "Nominal" refers to approximate size.

2400mm = (94 1/2")	Phone Line / Fax
2100mm = (82 5/8")	Internet connection
1800mm = (70 7/8")	Outlet
1500mm = (59")	Main Drop (point of distrution)
1200mm = (47 1/4")	
900mm = (35 1/2")	
600mm = (23 5/8")	
300mm = (11 7/8")	

--- Wire running under carpet

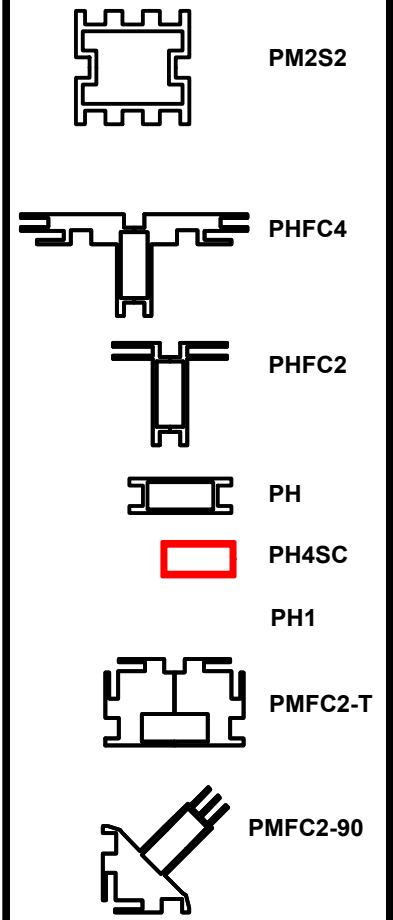
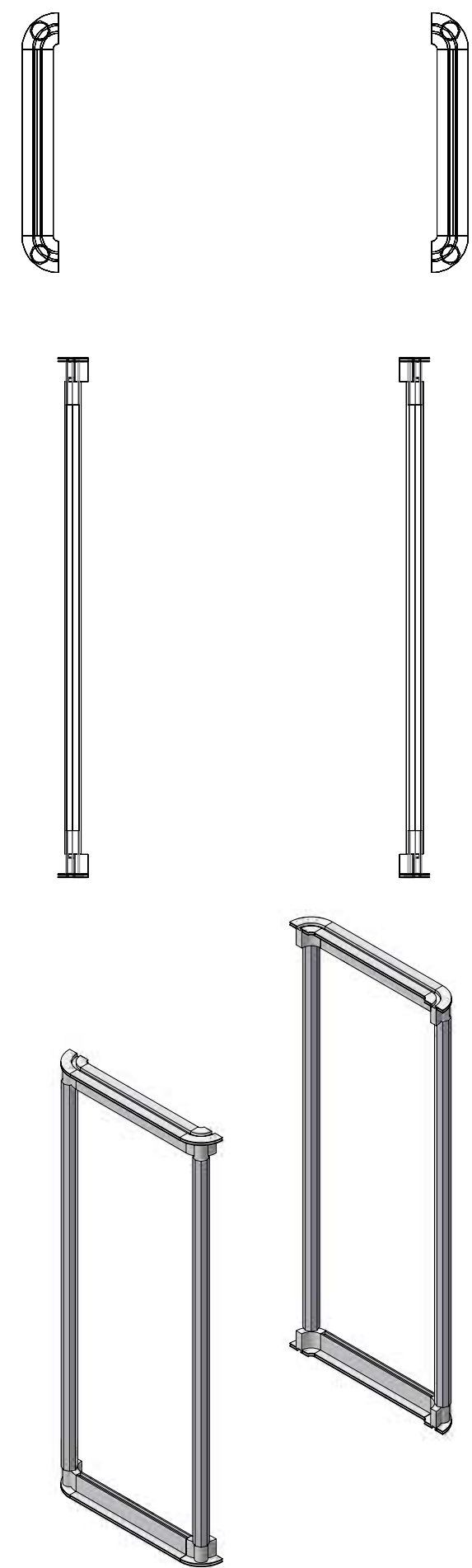
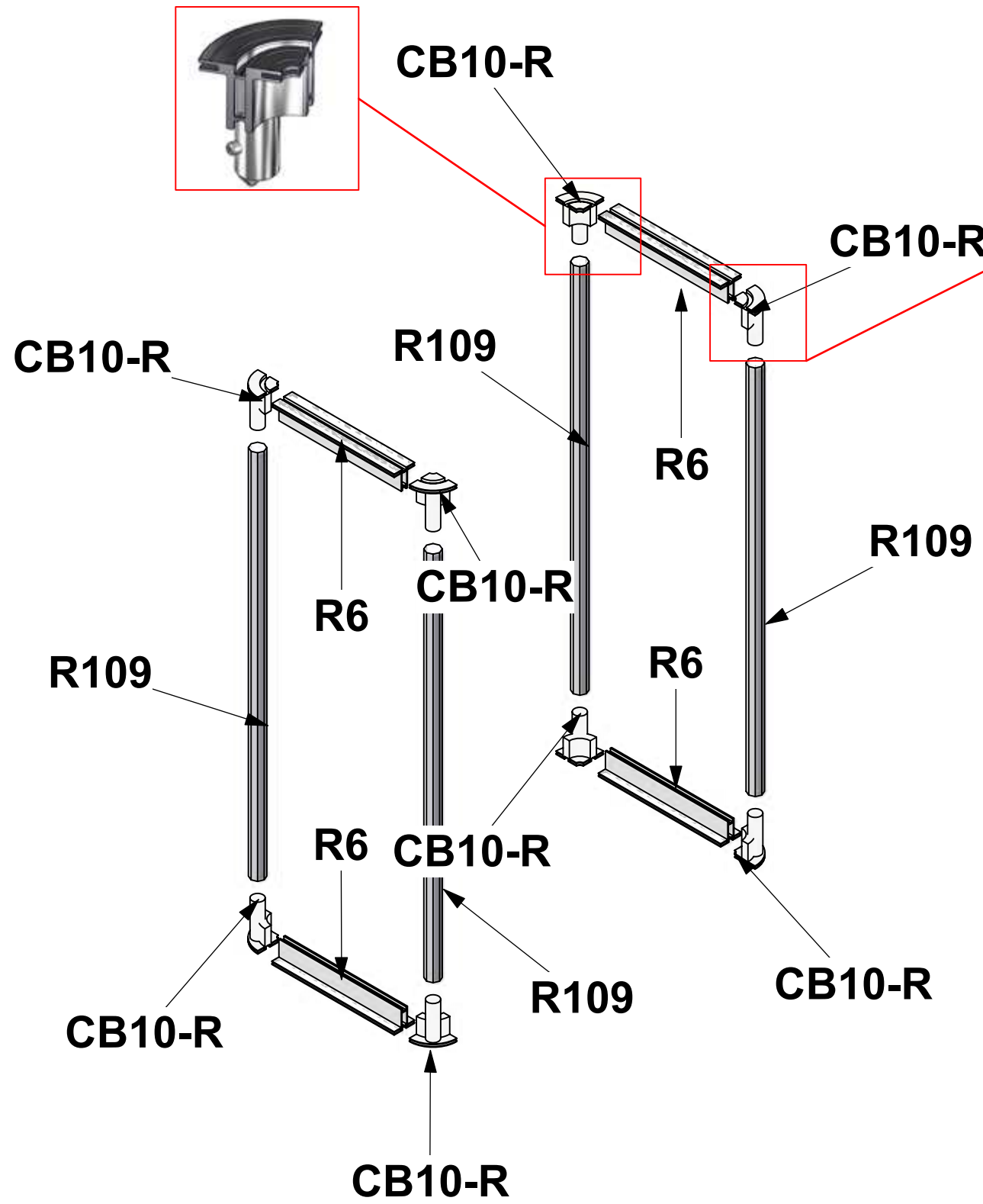

HYBRID PRO RENTAL KIT

Title: SET-UP INSTRUCTIONS

BUILD 2 UNITS

Code	#	Description
R5	4	100MM (3.94") PHFC2 EXTRUSION WITH LOCKS 2 ENDS
R4	2	600MM (23.62") PHFC2 EXTRUSION WITH LOCKS 2 ENDS
R3	2	986MM (38.82") PMFC2-90 EXTRUSION-WITH LOCKS BOTH ENDS
PMFC2-90 CA	4	PMFC2 90 DEGREE EXTRUSION CAP
R1	1	910MM (35.82") 50MM PM2S SQUARE EXTRUSION WITH LOCKS 2 ENDS

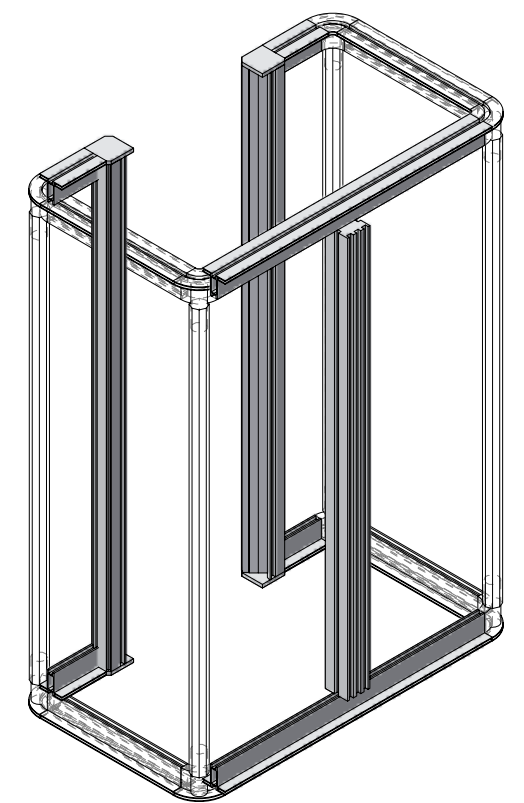
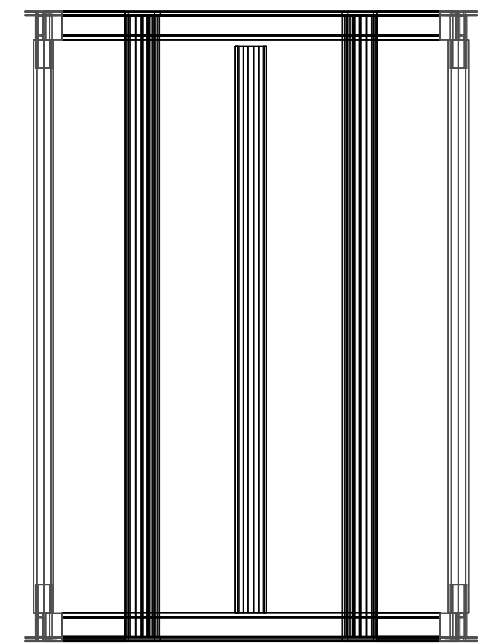
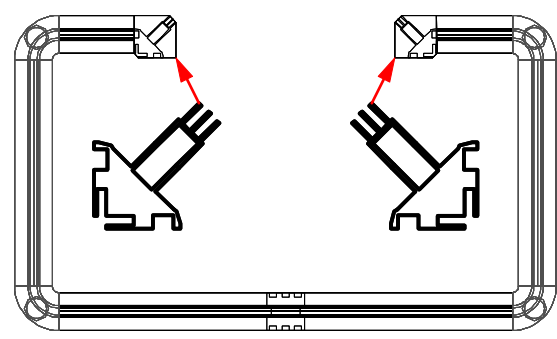
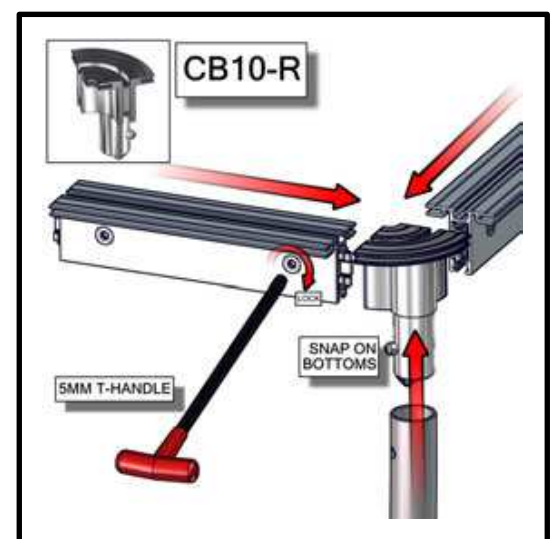
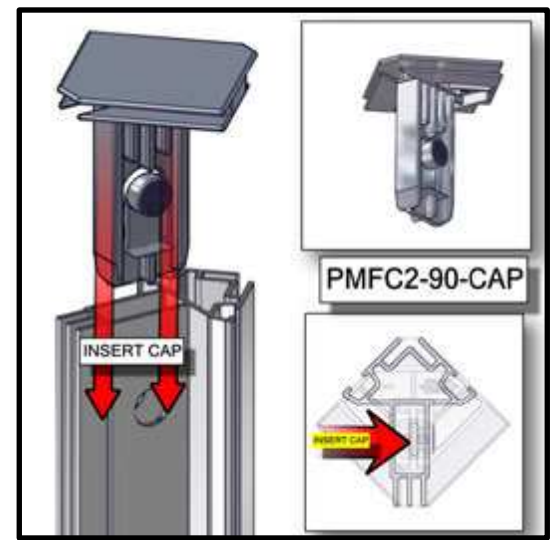
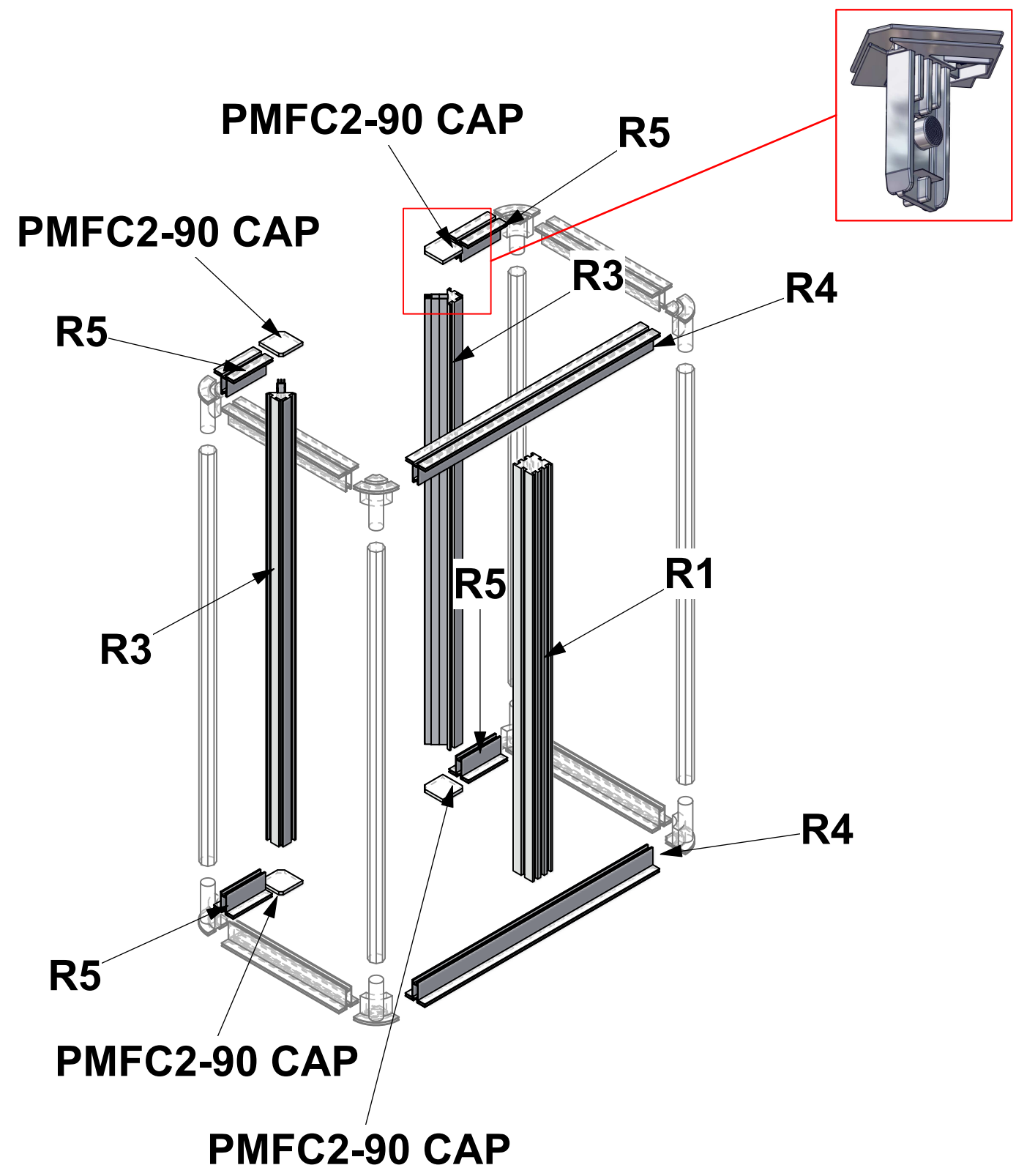

1. Redesign of this exhibit without approval by manufacturer may result in dangerous and unsafe structures. Manufacturer disclaims any responsibility for redesigned exhibits it does not approve in writing.

2. Parts and components such as panels and extrusions are manufactured to metric sizing. Where ever possible sizes have been noted in feet and inches as well as in metric. Below is the imperial to metric sizing table as reference. "Nominal" refers to approximate size.

2400mm = (94 1/2")	Phone Line / Fax
2100mm = (82 5/8")	Internet connection
1800mm = (70 7/8")	Outlet
1500mm = (59")	Main Drop (point of distrution)
1200mm = (47 1/4")	
900mm = (35 1/2")	
600mm = (23 5/8")	
300mm = (11 7/8")	

--- Wire running under carpet

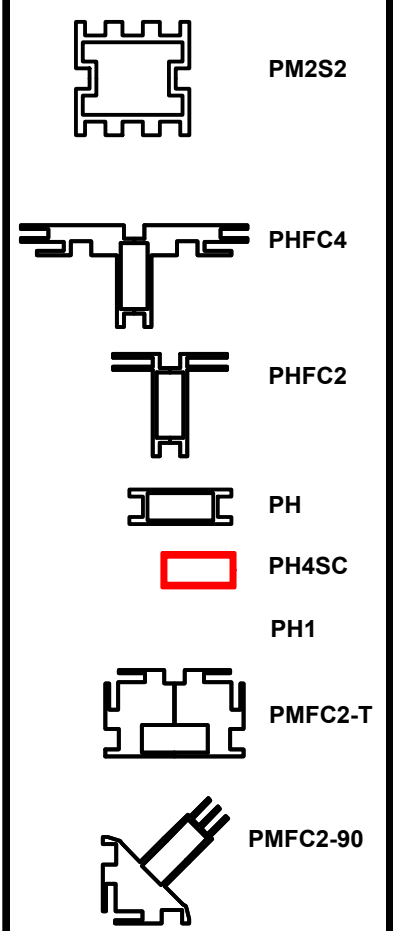

HYBRID PRO RENTAL KIT

Title: SET-UP INSTRUCTIONS

Code	#	Description
R2	4	288MM (11.34") PH1 EXTRUSION WITH LOCKS 2 ENDS
VFC-04-CT-S	1	INTERNAL SHELF FOR VECTOR COUNTER VFC-04
PE-1000	2	1000MM (39.37") PE EXTRUSION

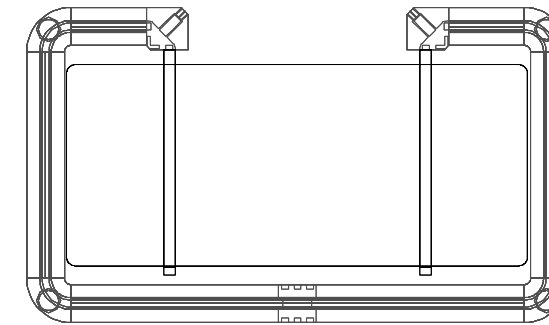
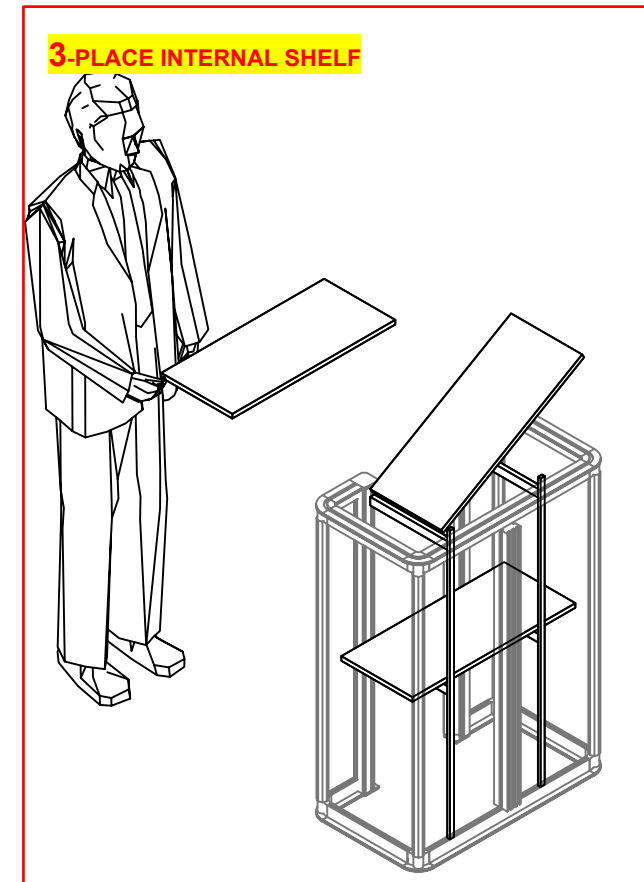
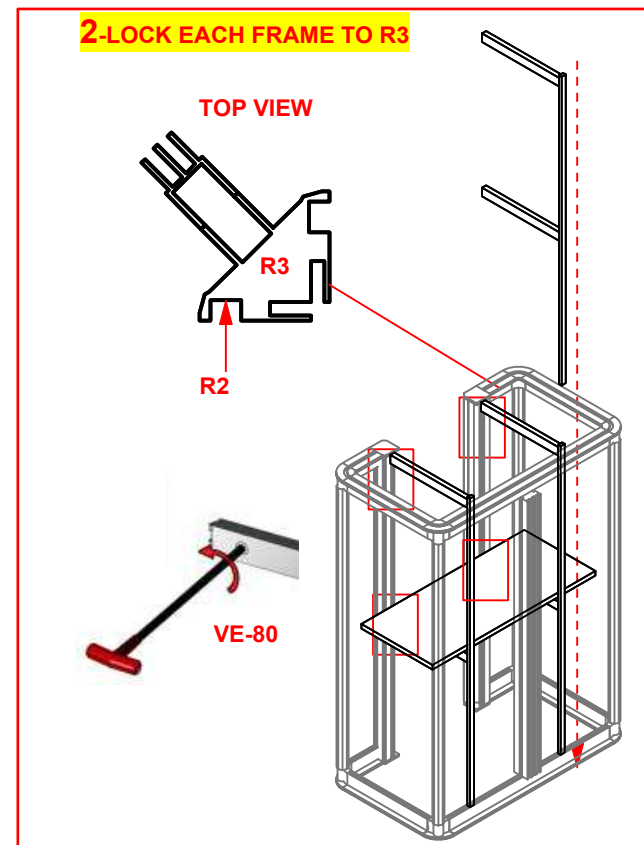
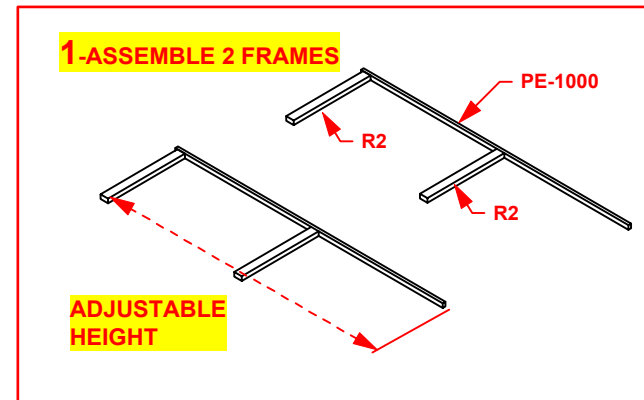
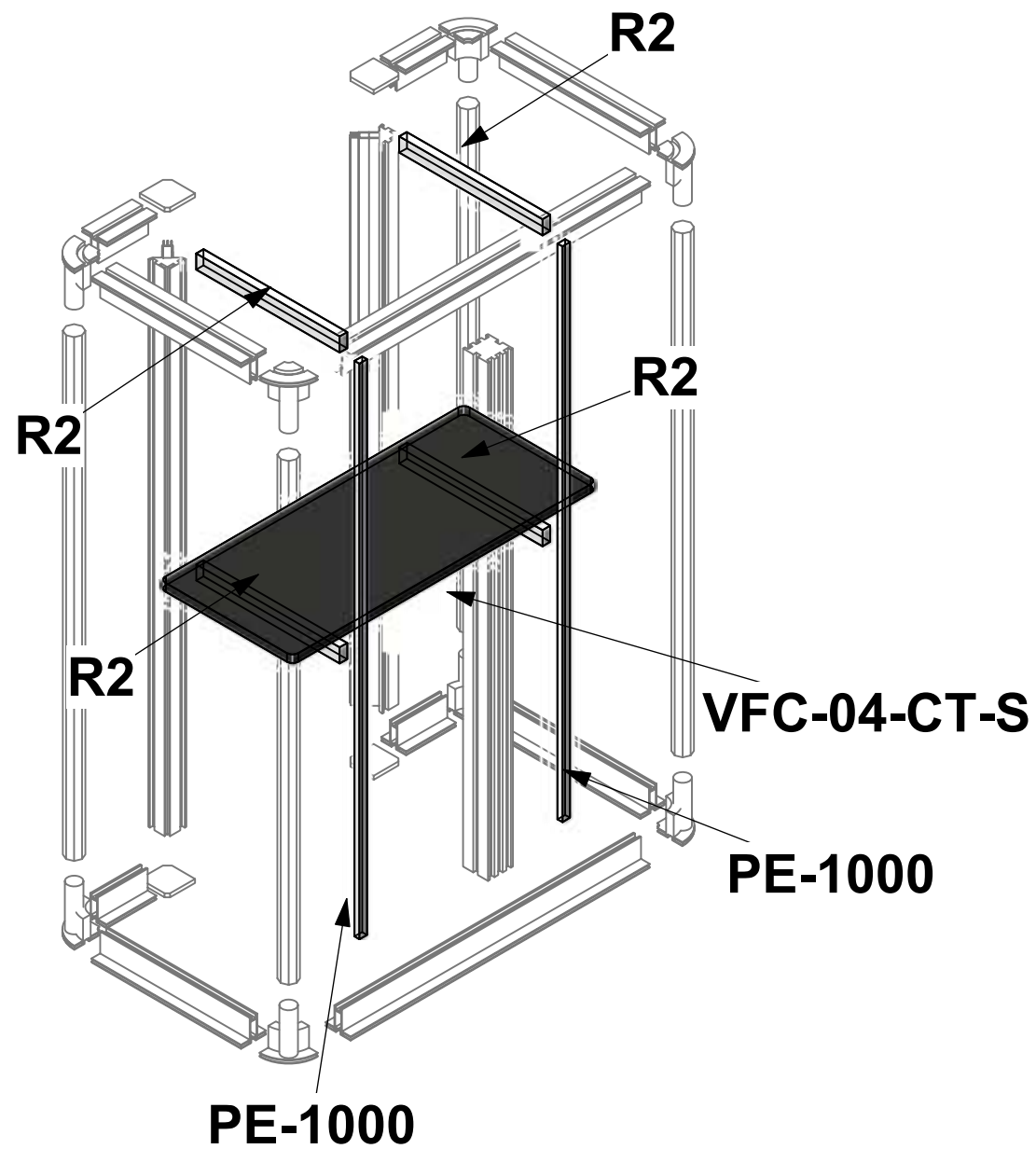

1. Redesign of this exhibit without approval by manufacturer may result in dangerous and unsafe structures. Manufacturer disclaims any responsibility for redesigned exhibits it does not approve in writing.

2. Parts and components such as panels and extrusions are manufactured to metric sizing. Where ever possible sizes have been noted in feet and inches as well as in metric. Below is the imperial to metric sizing table as reference. "Nominal" refers to approximate size.

2400mm = (94 1/2")	Phone Line / Fax
2100mm = (82 5/8")	Internet connection
1800mm = (70 7/8")	Outlet
1500mm = (59")	Main Drop (point of distrution)
1200mm = (47 1/4")	
900mm = (35 1/2")	
600mm = (23 5/8")	
300mm = (11 7/8")	

--- Wire running under carpet

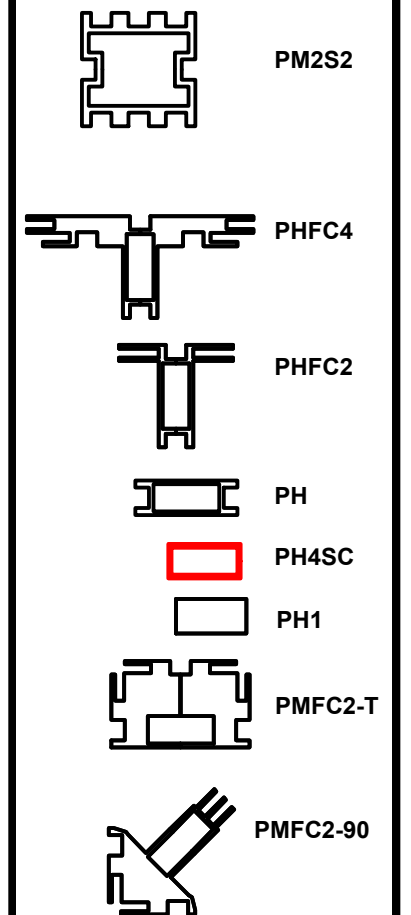

HYBRID PRO RENTAL KIT

Title: SET-UP INSTRUCTIONS

Code	#	Description
GRAPHIC	1	43 3/8" (H) X 15 1/2" (W) SINGLE SIDED DYESUB C
VFC-04-CT	1	3' X 2' LAMINATE COUNTER TOP [BLACK THERM
GRAPHIC	1	43 3/8" (H) X 77 1/4" (W) SINGLE SIDED DYESUB C

VFC-04-CT

GRAPHIC

NOTE: USE THIS FABRIC ONLY WHEN COUNTER IS FREESTANDING

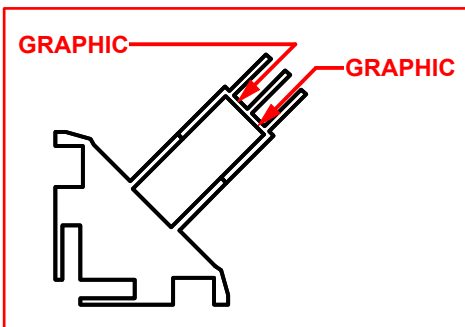
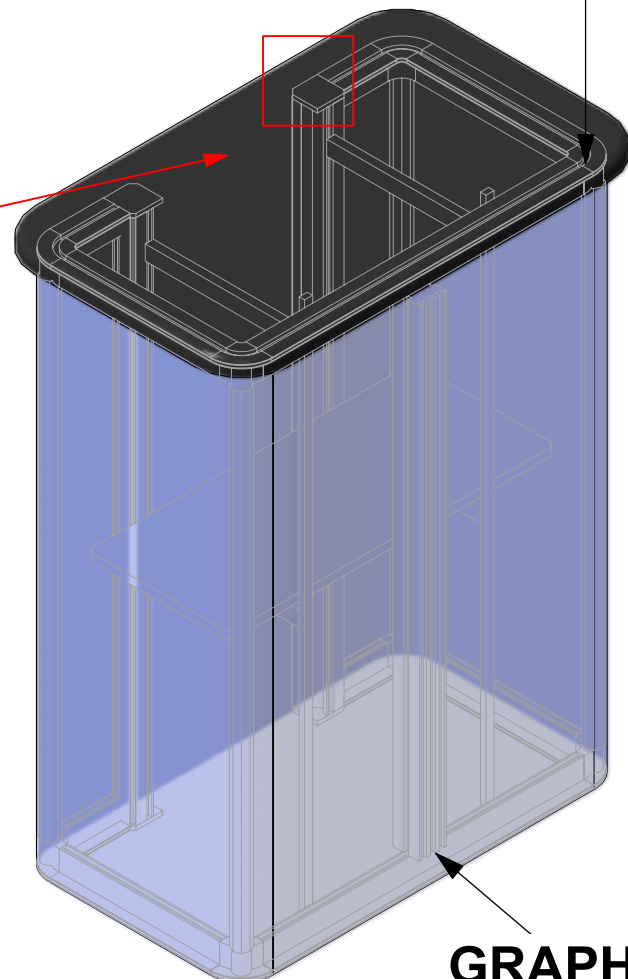

LIFT UP COUNTER FOR ACCESS INSIDE

GRAPHIC

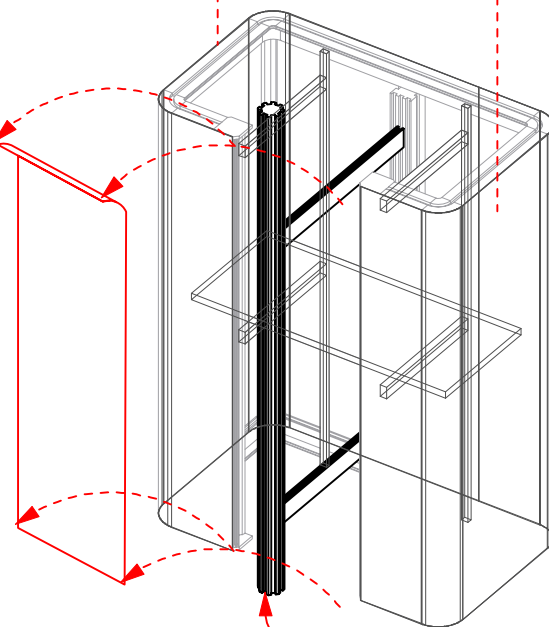

BACKWALL NOT INCLUDED

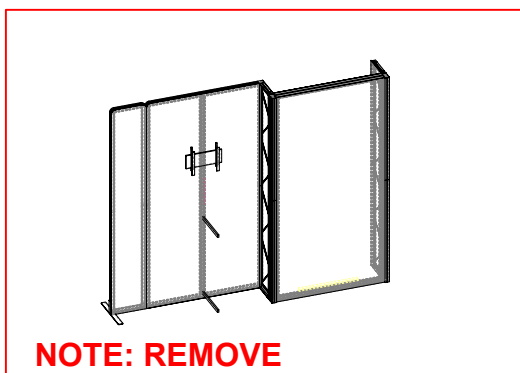

NOTE: REMOVE FABRIC WHEN COUNTER IS ATTACHED TO BACKWALL

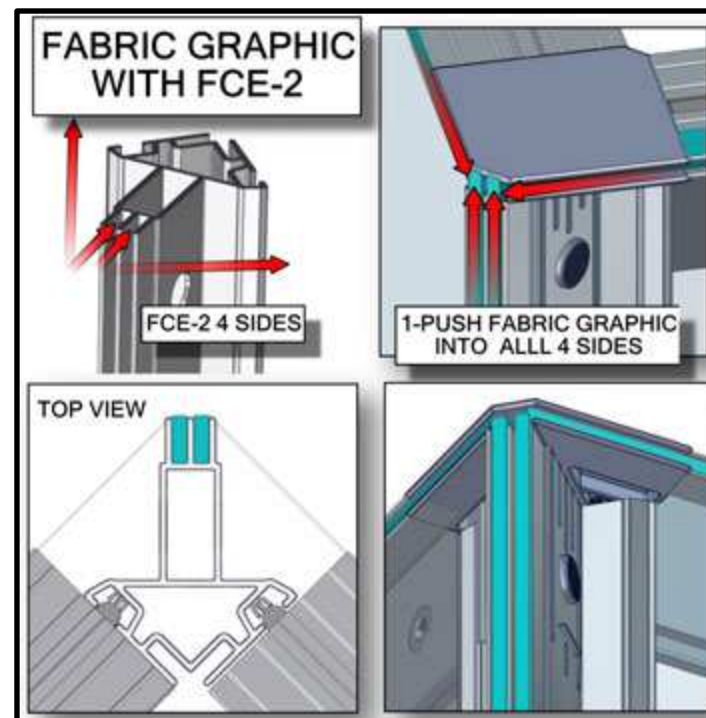
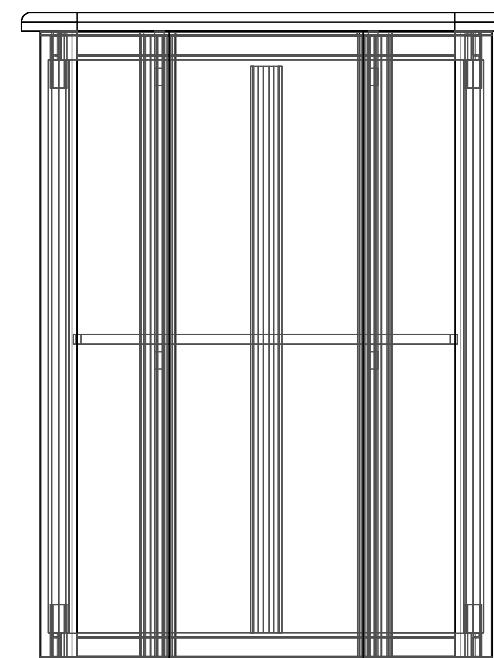
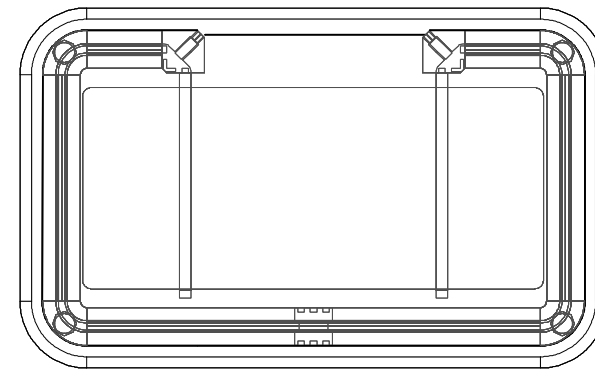





1. Redesign of this exhibit without approval by manufacturer may result in dangerous and unsafe structures. Manufacturer disclaims any responsibility for redesigned exhibits it does not approve in writing.

2. Parts and components such as panels and extrusions are manufactured to metric sizing. Where ever possible sizes have been noted in feet and inches as well as in metric. Below is the imperial to metric sizing table as reference. "Nominal" refers to approximate size.

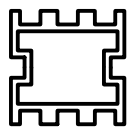
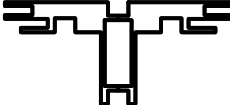
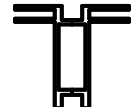
2400mm = (94 1/2")	Phone Line / Fax
2100mm = (82 5/8")	Internet connection
1800mm = (70 7/8")	Outlet
1500mm = (59")	Main Drop (point of distrution)
1200mm = (47 1/4")	
900mm = (35 1/2")	
600mm = (23 5/8")	
300mm = (11 7/8")	

--- Wire running under carpet

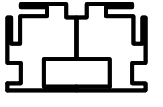
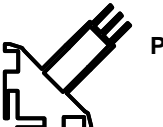
-  **PM2S2**
-  **PHFC4**
-  **PHFC2**
-  **PH**
-  **PH4SC**
-  **PH1**
-  **PMFC2-T**
-  **PMFC2-90**

HYBRID PRO RENTAL KIT

Title: SET-UP INSTRUCTIONS

PACKING INSTRUCTIONS

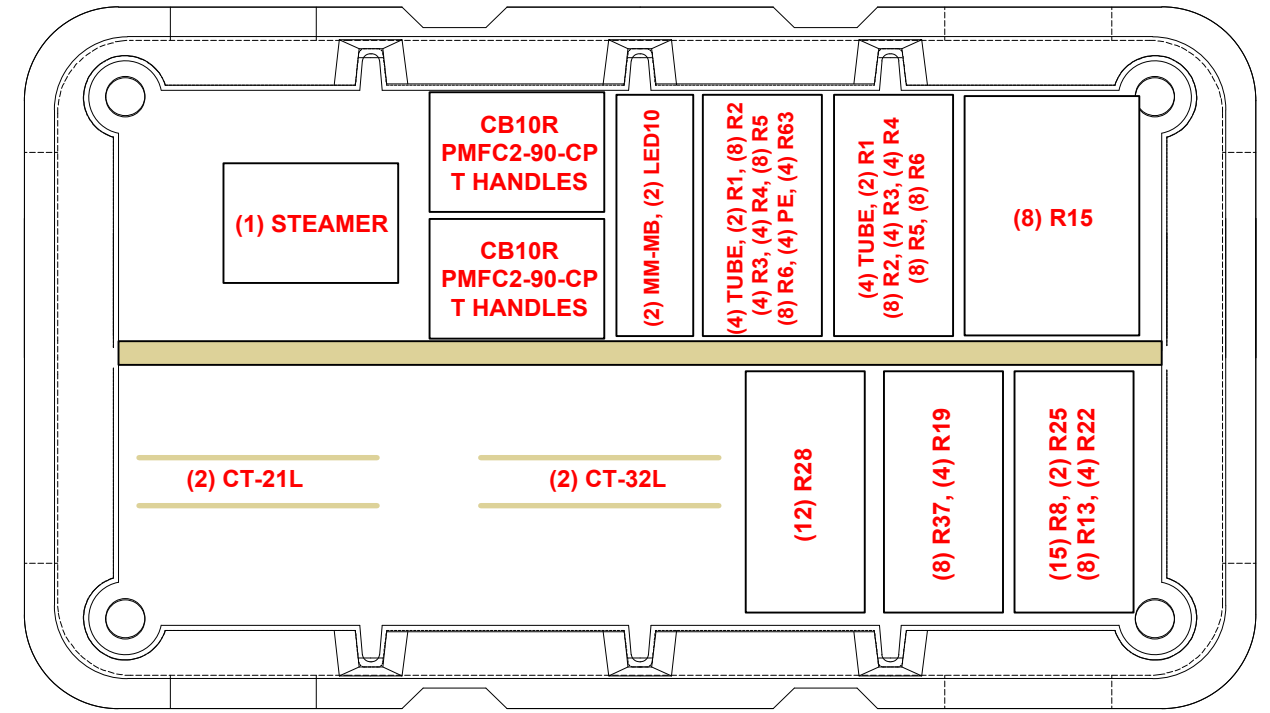

HARDWARE BOX



CASE # 1

LEGEND		
	GREY FOAM FOLDED TO FILL EMPTY SPACES OR USED AS PROTECTION	
	1/8" CARDBOARD SPACER (PUT IN BETWEEN EVERY PANEL)	
	DIVIDER	
	1/4" WHITE FOAM (USED AS PROTECTION DOOR PANELS W/ LOCKS)	

