

Hybrid Pro Modular Kit 01

HP-K-01

Hybrid Pro™ Modular exhibits and counters are a perfect solution for the serious exhibitor. Exhibits feature heavy-duty aluminum extrusion frames and push-fit fabric graphics. Count on making an unforgettable impact with Hybrid Pro Modular exhibit kits, counters, and accessories.

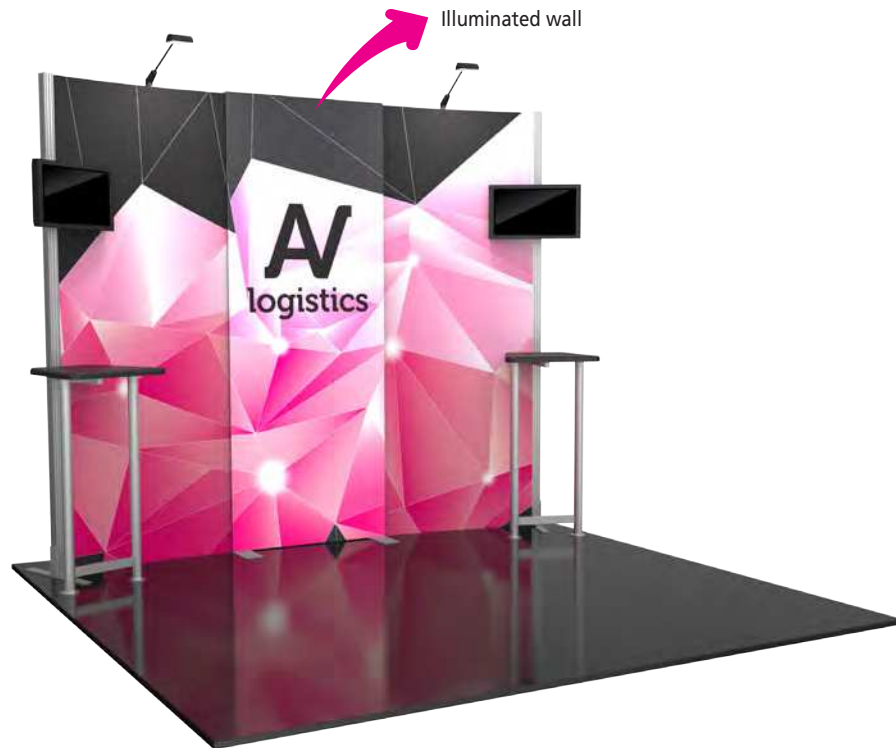

features and benefits:

- Silver aluminum extrusion frame
- Illuminated SEG push-fit center graphic panel with interior top and bottom LED lighting
- Single-sided SEG dye-sublimated push-fit fabric graphics
- Kit includes frame, two fabric graphic panels, one illuminated graphic panel, two tables, two 200 LED floodlights, two small monitor mounts and two molded OCH2 cases
- Lifetime hardware warranty against manufacturer defects

dimensions:

Hardware

Assembled unit:
111.25" w x 94.75" h x 34.75" d
2825.75mm(w) x 2406.65mm(h) x 882.65mm(d)

Tables:
21" w x 40.5" h x 19.7" d approx.
533.4mm(w) x 1028.7mm(h) x 500.38mm(d)

Tables hold max weight 25 lbs / 11.34 kgs

Shipping

Shipping dimensions - ships in cases:
2 OCH2 cases (each case): 52" l x 30" w x 14" h
1320.8mm(l) x 762mm(w) x 355.6mm(h)

Approximate shipping weight (entire kit):
196 lbs / 89 kgs

Graphic

Total visual area:
Panels A & C: 36.06" w x 94.375" h
916mm(w) x 2397mm(h)

Panel B: 35.3125" w x 94.375" h
897mm(w) x 2397mm(h)

Please consider obstructions and spaces created by the extrusions when designing graphics. Be sure to include a 2" bleed around the perimeter.



ZZZ FDPHOEDFNGLVSD\

additional information:

Graphic material:
Dye-sublimated fabric

Tabletop color options:

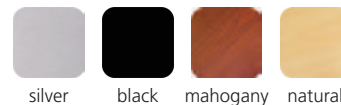

silver black mahogany natural

Lights Included:
Lumina 200 LED floodlight, straight arm and adjustable head, black finish, 19.5" from end to end

Small monitor bracket holds 13-39" LCD, maximum weight: 25 lbs / 11.34 kgs

We are continually improving and modifying our product range and reserve the right to vary the specifications without prior notice. All dimensions and weights quoted are approximate and we accept no responsibility for variance. E&OE. See Graphic Templates for graphic bleed specifications.

R-HP-K-01

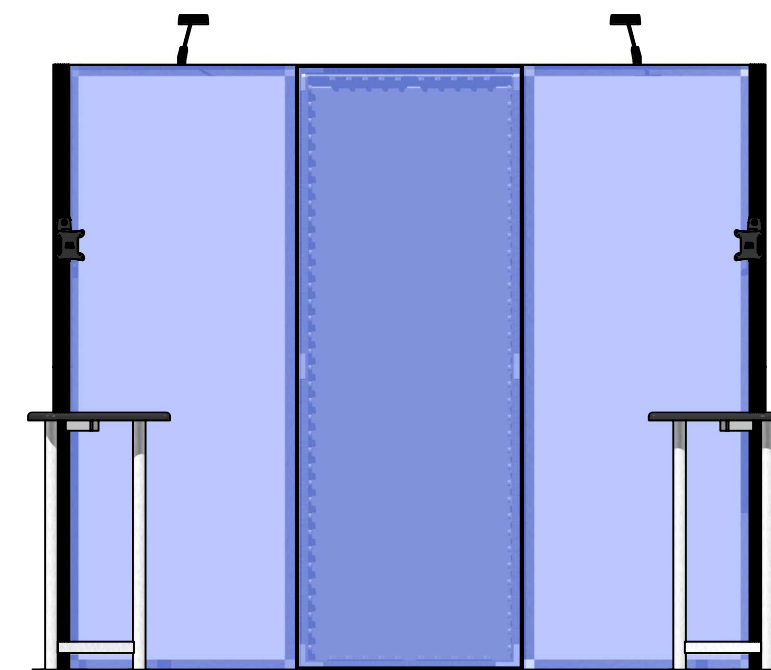
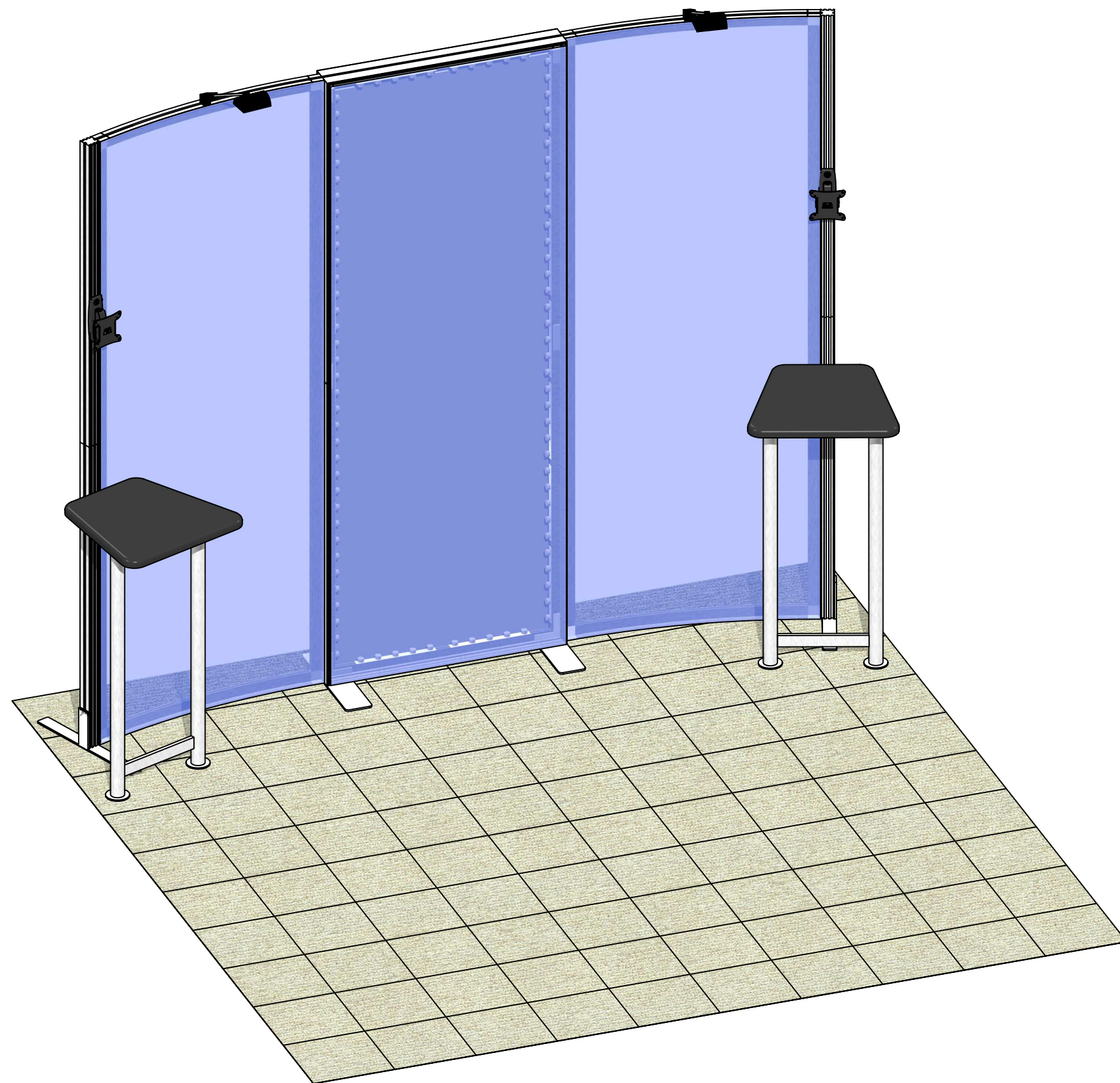

Code	#	Description
GRAPHIC A1	1	94.5"H X 36.182"W SINGLE SIDED DYESUB GRAPHIC W/FCE-2 ON PERIMETER
LN114-S2-450	2	LINEAR FOOT WITH COUNTERSUNK HOLES, NIKE HAMMERTONE SILVER, 450MM LENGTH
R26	2	900MM (35.43") PHFC4 EXTRUSION WITH MITRE CUT BOTH ENDS
CB9	4	CB9 CORNER BRACKET
IB2	6	INLINE BRACKET CONNECTOR
R27	4	1200MM (47.24") PHFC4 EXTRUSION WITH MITRE CUT 1 END FOR CB9 ONE END-IB2 HOLES ONE END
LED-WHT-DB-300	18	300MM (11.81") LENGTH LED LIGHTS FOR DIRECTIONAL BACKLIGHT
GRAPHIC B	1	94.5"H X 35.43"W BACKLIT DYESUB GRAPHIC W/FCE-2 ON PERIMETER
UNPRINTED B	1	94.5"H X 32.43"W WHITE FABRIC W/FCE-2 ON PERIMETER
V-M-BRACKET-01	2	VM1 MONITOR BRACKET
SM-MB	2	SMALL MONITOR BRACKET
SW-FOOT	2	SMARTWALL SUPPORT FOOT
R15	4	1200MM (47.24") 50MM50MM PM2S SQUARE EXTRUSION WITH STOP AT 155MM
R25	2	PH4SC-300MM (11.81") EXTRUSION WITH TENSION GLIDES
R8	2	300MM (11 13/16") PH WITH SLIDE LOCK AT BOTH ENDS
V-LG-05	2	1005MM X 425MM (39 9/16" X 16 3/4") RECTANGLE LEG 50MM CHANNEL
V-WS-CT-01	2	500MM X 538MM (19 11/16" X 21 3/16") TAPERED WORKSTATION TOP
CB9-S	8	50MM SQUARE PHCF2 CORNER BRACKET
R20	4	PHFC2-8R-20 EXTRUSION WITH LOCKS 2 ENDS
R19	8	1155MM (45.47") PHFC2 EXTRUSION WITH IB2 HOLE ONE SIDE-WITH LOCK 1 END
LEDL10B	2	LED SPOTLIGHT,3M,UL PLUG W/TRANSFORMER BLACK
GRAPHIC A2	1	94.5"H X 36.182"W SINGLE SIDED DYESUB GRAPHIC W/FCE-2 ON PERIMETER

BOM

R-HP-K-01

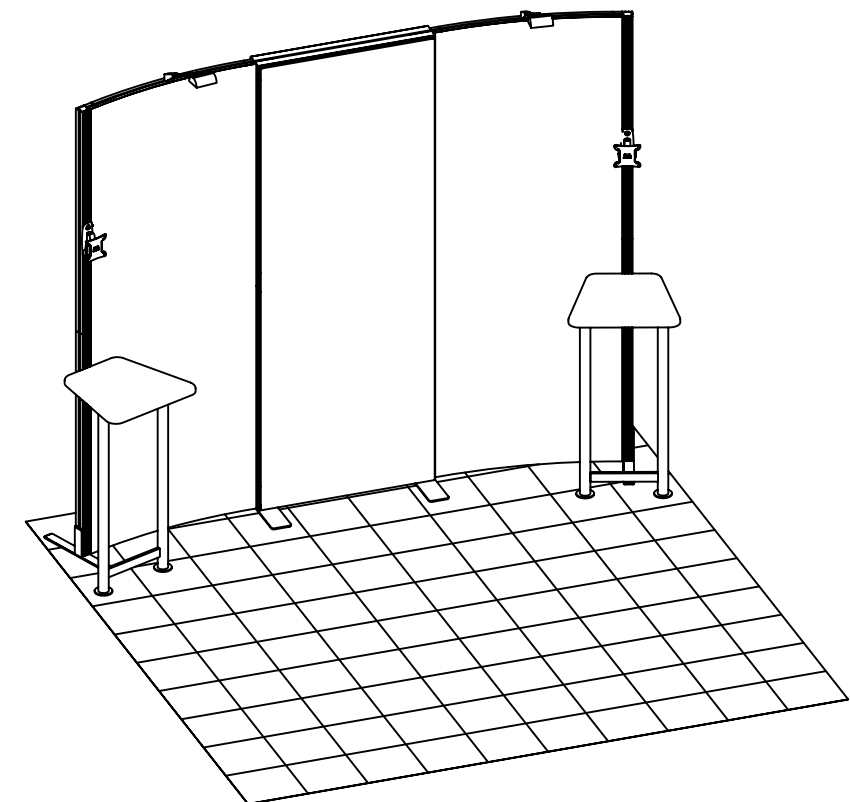
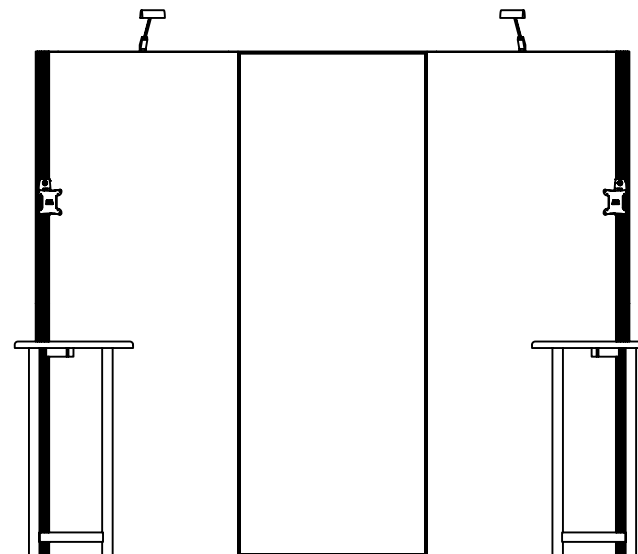
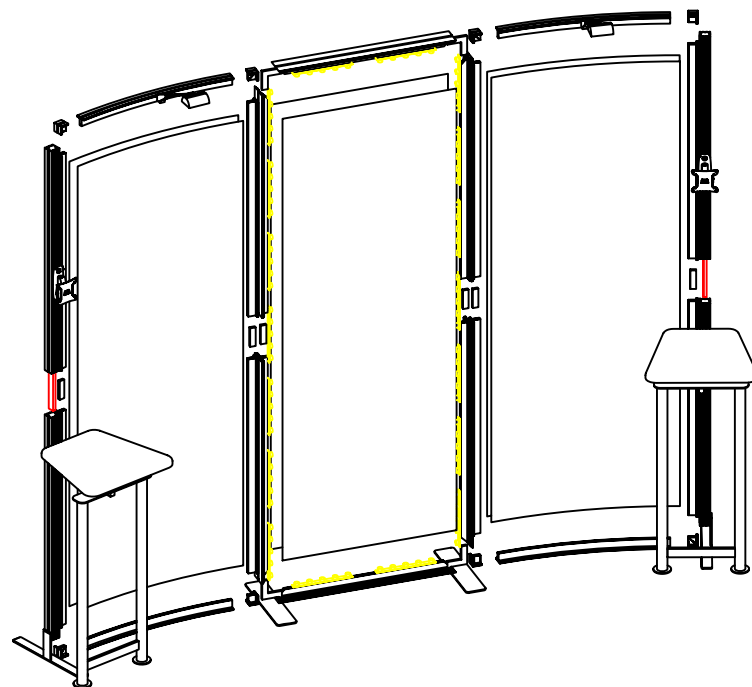
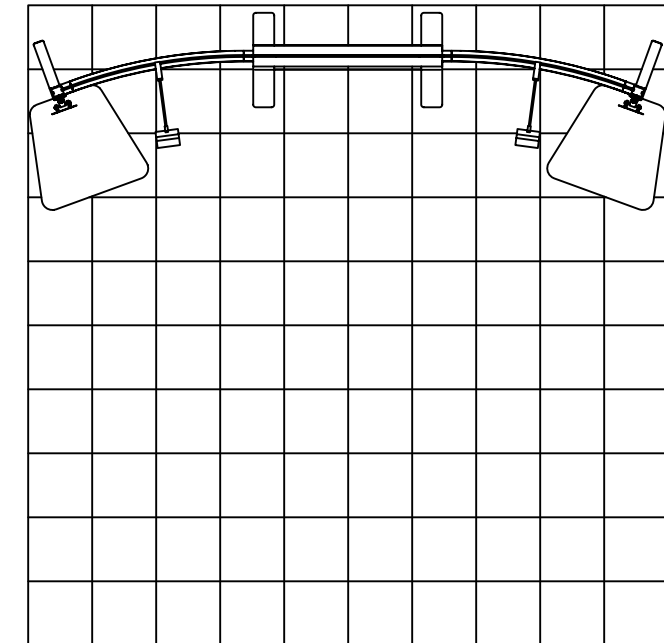



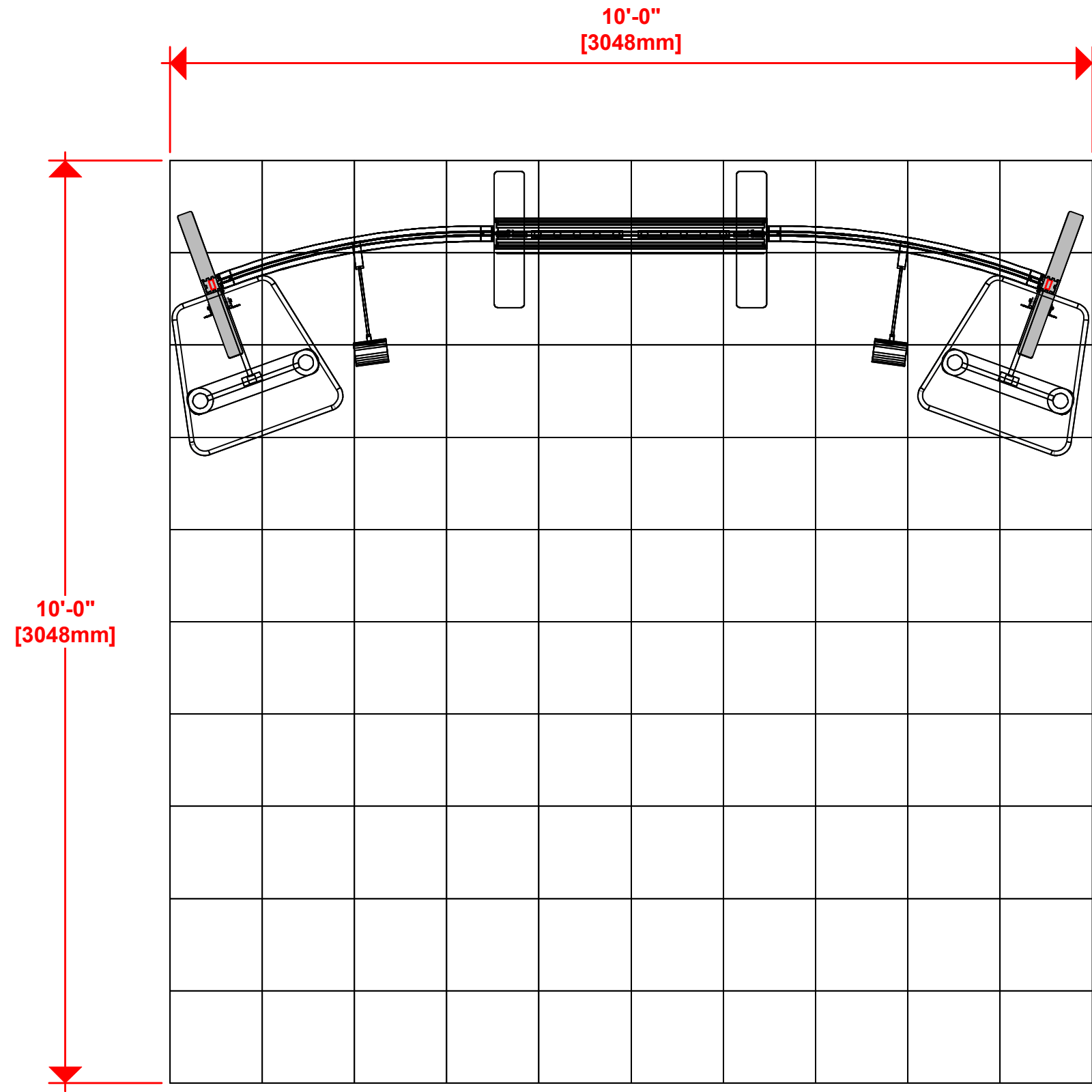

1. Redesign of this exhibit without approval by manufacturer may result in dangerous and unsafe structures. Manufacturer disclaims any responsibility for redesigned exhibits it does not approve in writing.

2. Parts and components such as panels and extrusions are manufactured to metric sizing. Where ever possible sizes have been noted in feet and inches as well as in metric. Below is the imperial to metric sizing table as reference. "Nominal" refers to approximate size.

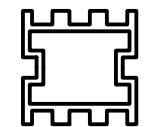
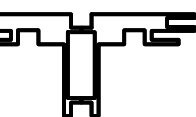
- | | |
|--------------------|-----------------------------------|
| 2400mm = (94 1/2") | ☒ Phone Line / Fax |
| 2100mm = (82 5/8") | ☒ Internet connection |
| 1800mm = (70 7/8") | ☒ Outlet |
| 1500mm = (59") | ☒ Main Drop (point of distrution) |
| 1200mm = (47 1/4") | |
| 900mm = (35 1/2") | |
| 600mm = (23 5/8") | |
| 300mm = (11 7/8") | |
- Wire running under carpet



-  PM2S2
-  PHFC4
-  PHFC2
-  PH
-  PH4SC

HYBRID PRO RENTAL KIT

Title: SET-UP INSTRUCTIONS

LED-WHT-DB-300 LIGHTS

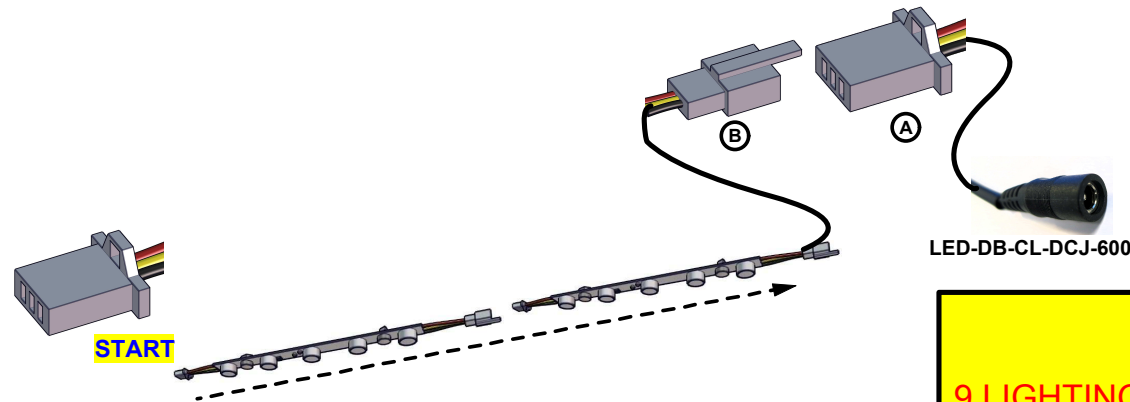
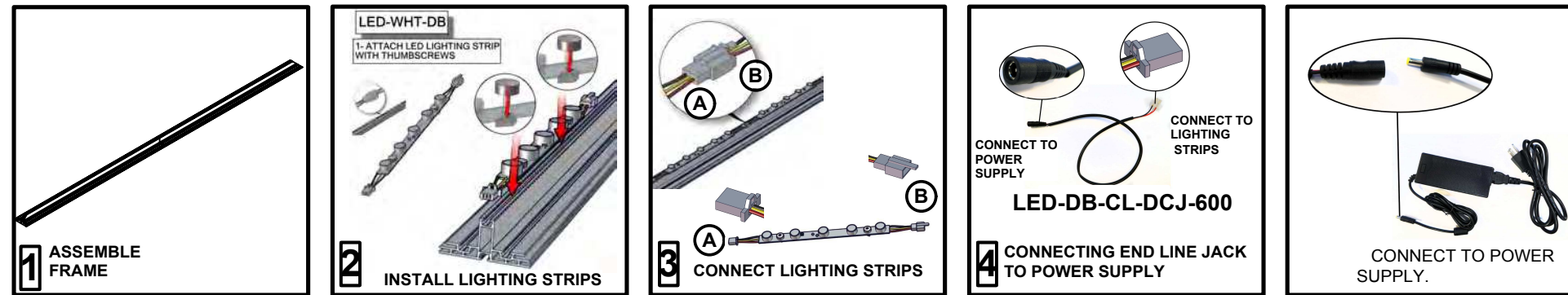

IMPORTANT!
9 LIGHTING STRIPS MAXIMUM
PER POWER SUPPLY

END LINE CONNECTORS & POWER SUPPLY

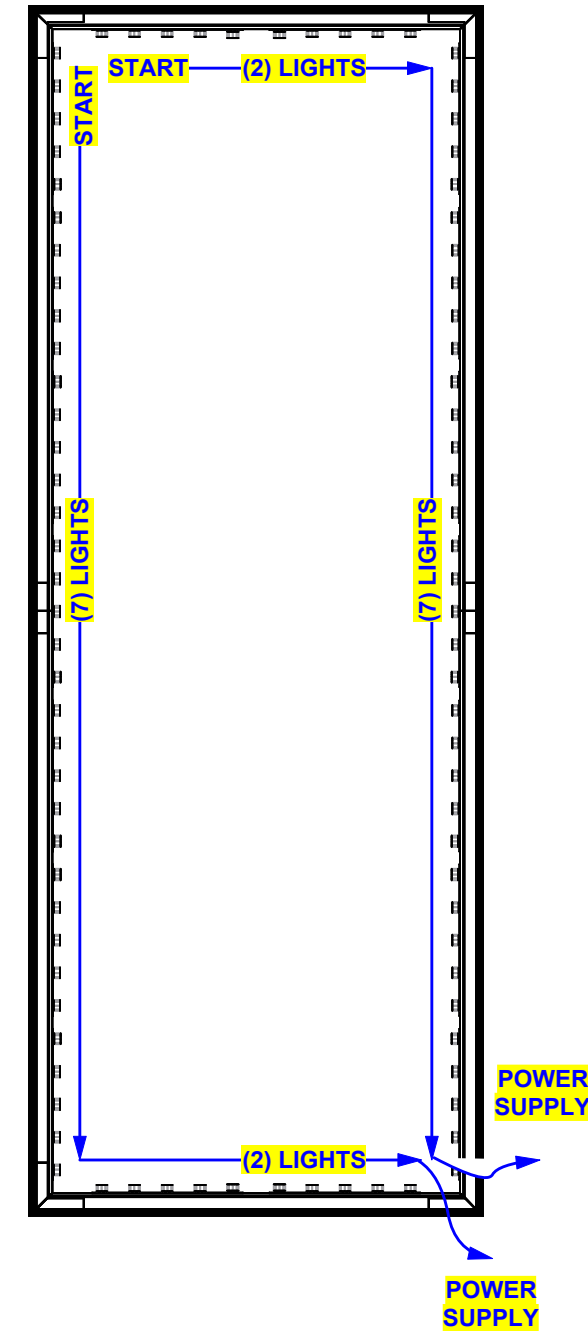
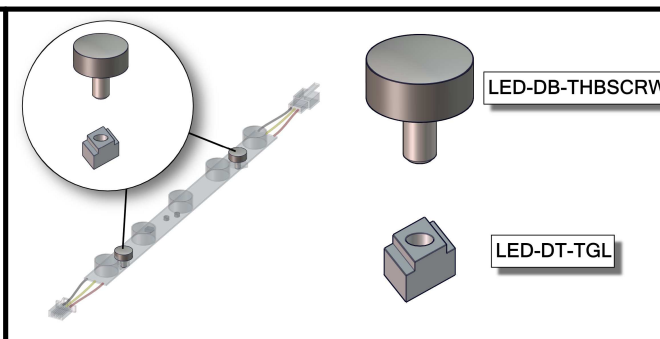
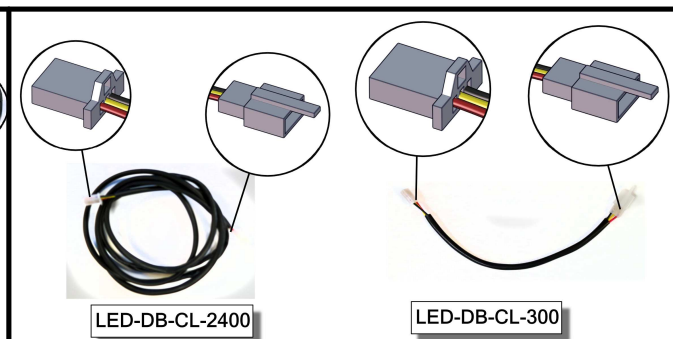
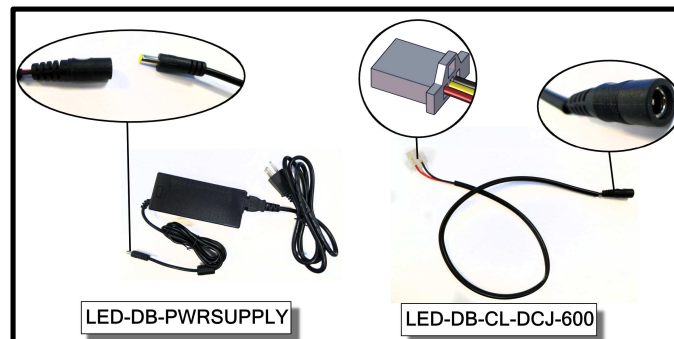

1. Redesign of this exhibit without approval by manufacturer may result in dangerous and unsafe structures. Manufacturer disclaims any responsibility for redesigned exhibits it does not approve in writing.

2. Parts and components such as panels and extrusions are manufactured to metric sizing. Where ever possible sizes have been noted in feet and inches as well as in metric. Below is the imperial to metric sizing table as reference. "Nominal" refers to approximate size.

2400mm = (94 1/2")	Phone Line / Fax
2100mm = (82 5/8")	Internet connection
1800mm = (70 7/8")	Outlet
1500mm = (59")	Main Drop (point of distrution)
1200mm = (47 1/4")	
900mm = (35 1/2")	
600mm = (23 5/8")	
300mm = (11 7/8")	

--- Wire running under carpet

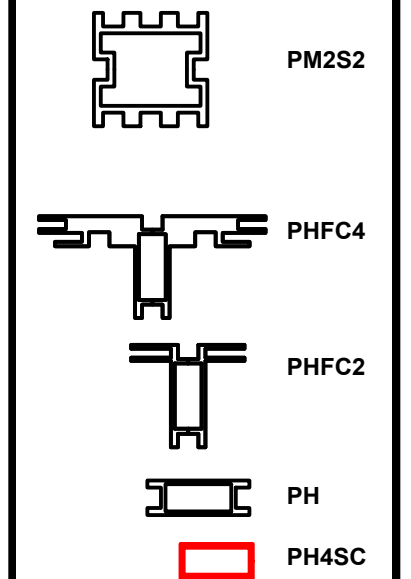

HYBRID PRO RENTAL KIT

Title: SET-UP INSTRUCTIONS

Code	#	Description
R26	2	900MM (35.43") PHFC4 EXTRUSION WITH MITRE CUT BOTH ENDS
CB9	4	CB9 CORNER BRACKET
IB2	2	INLINE BRACKET CONNECTOR
R27	4	1200MM (47.24") PHFC4 EXTRUSION WITH MITRE CUT 1 END FOR CB9 ONE END-IB2 HOLES ONE END
LED-WHT-DB-300	18	300MM (11.81") LENGTH LED LIGHTS FOR DIRECTIONAL BACKLIGHT

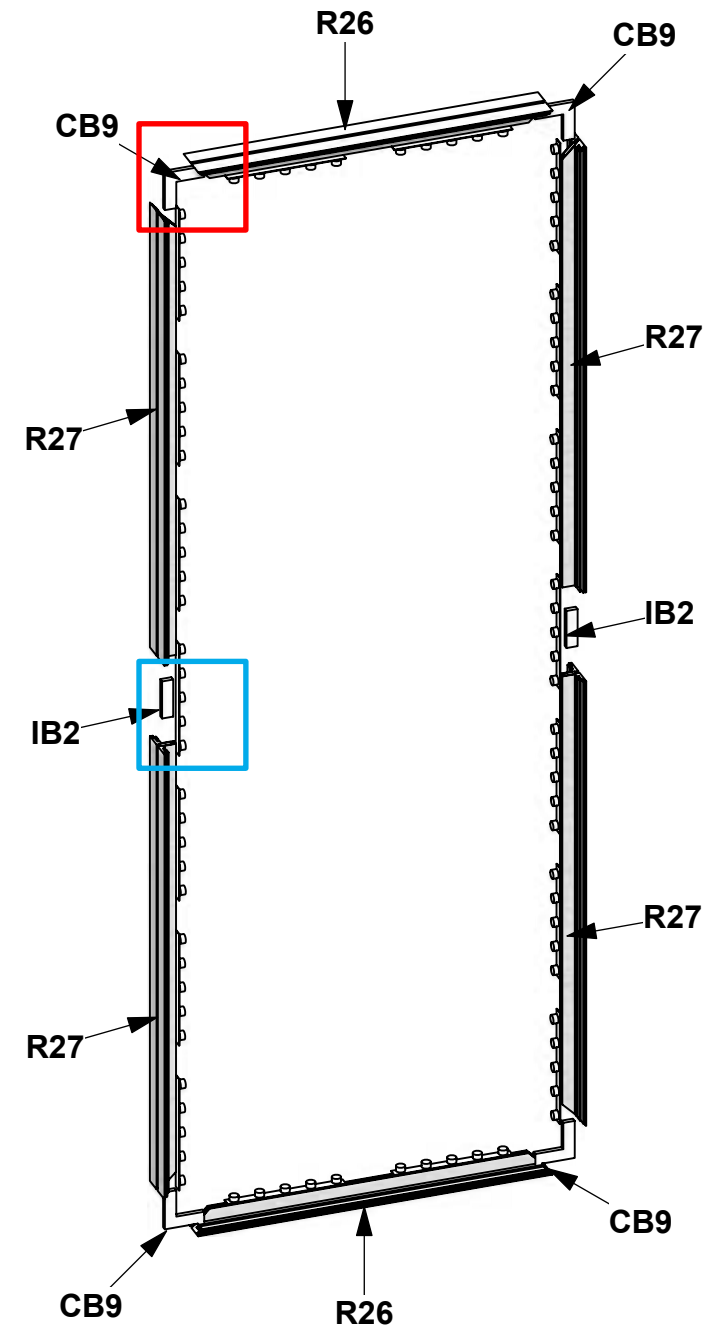
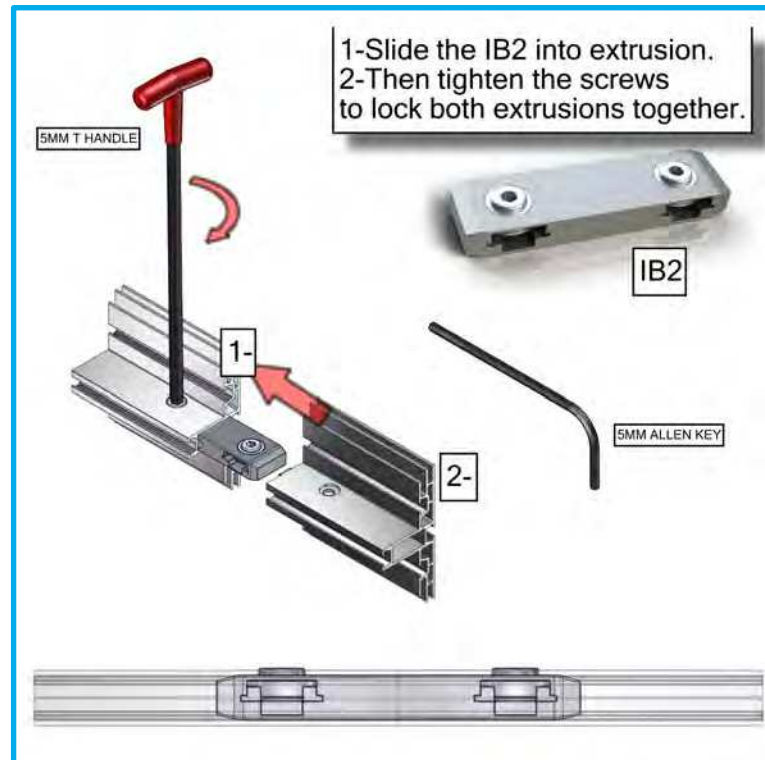
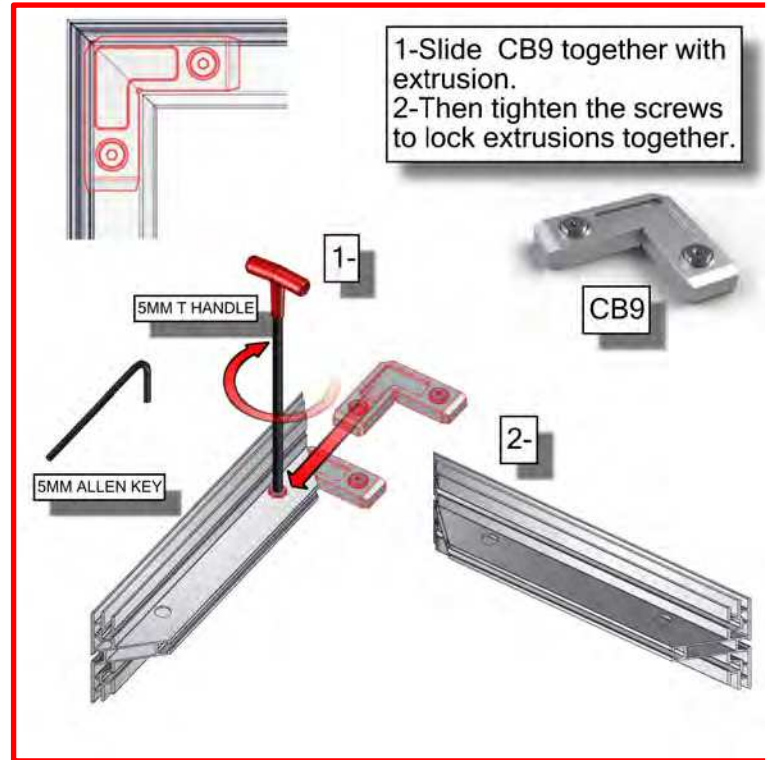
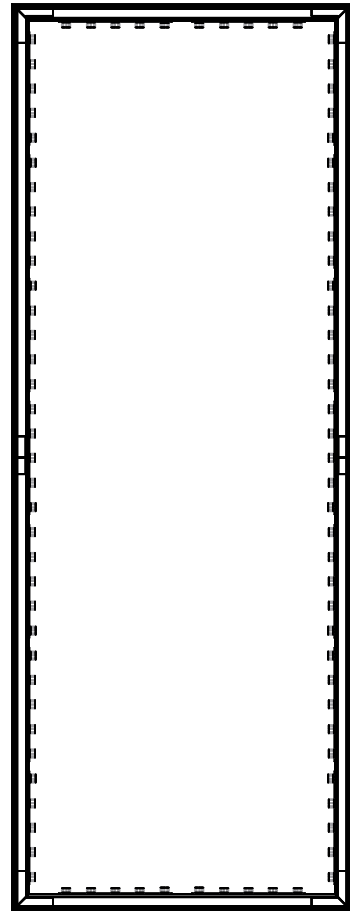

1. Redesign of this exhibit without approval by manufacturer may result in dangerous and unsafe structures. Manufacturer disclaims any responsibility for redesigned exhibits it does not approve in writing.

2. Parts and components such as panels and extrusions are manufactured to metric sizing. Where ever possible sizes have been noted in feet and inches as well as in metric. Below is the imperial to metric sizing table as reference. "Nominal" refers to approximate size.

2400mm = (94 1/2")	Phone Line / Fax
2100mm = (82 5/8")	Internet connection
1800mm = (70 7/8")	Outlet
1500mm = (59")	Main Drop (point of distrution)
1200mm = (47 1/4")	
900mm = (35 1/2")	
600mm = (23 5/8")	
300mm = (11 7/8")	

--- Wire running under carpet

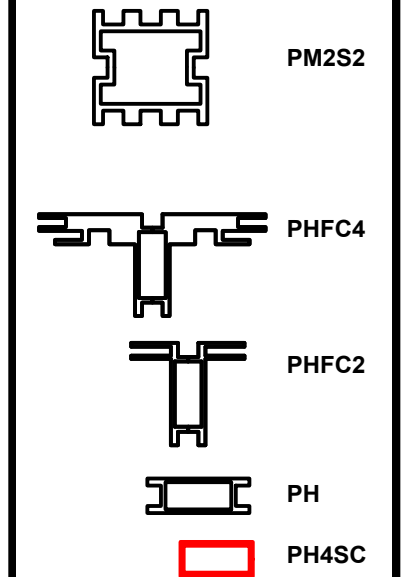

HYBRID PRO RENTAL KIT

Title: SET-UP INSTRUCTIONS

Code	#	Description
LN114-S2-450	2	LINEAR FOOT WITH COUNTERSUNK HOLES, NIKE HAMMERTONE SILVER, 450MM LENGTH
GRAPHIC B	1	94.5"H X 35.43"W BACKLIT DYESUB GRAPHIC W/FCE-2 ON PERIMETER
UNPRINTED B	1	94.5"H X 32.43"W WHITE FABRIC W/FCE-2 ON PERIMETER

FCE-2 TO PHFC4

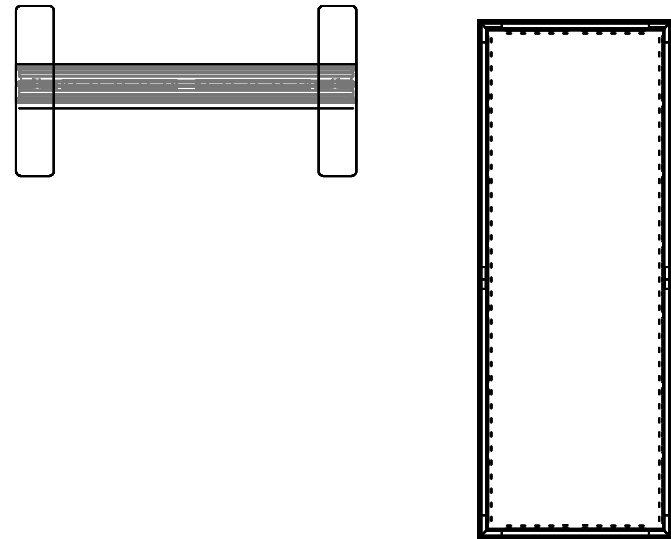
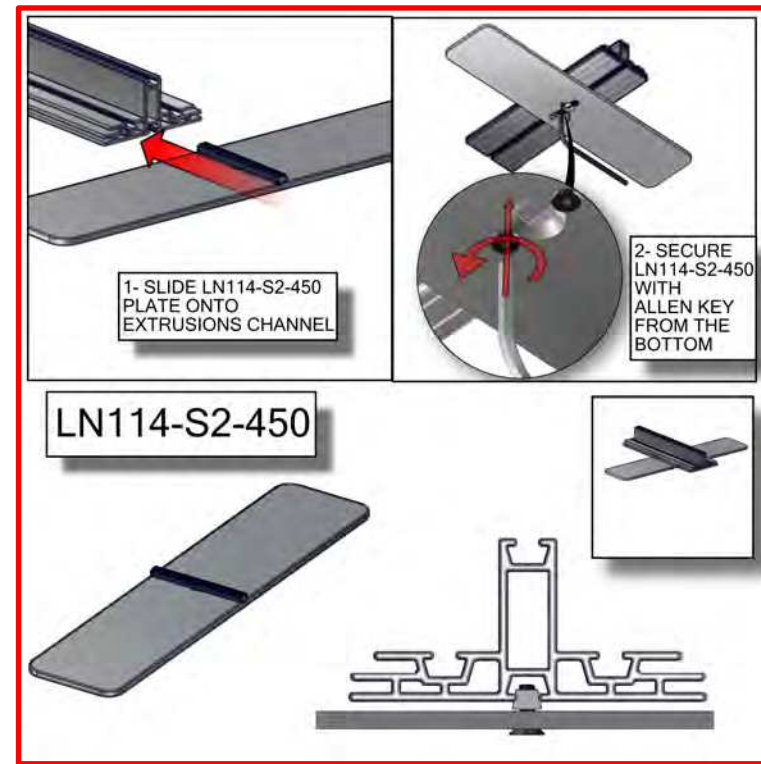
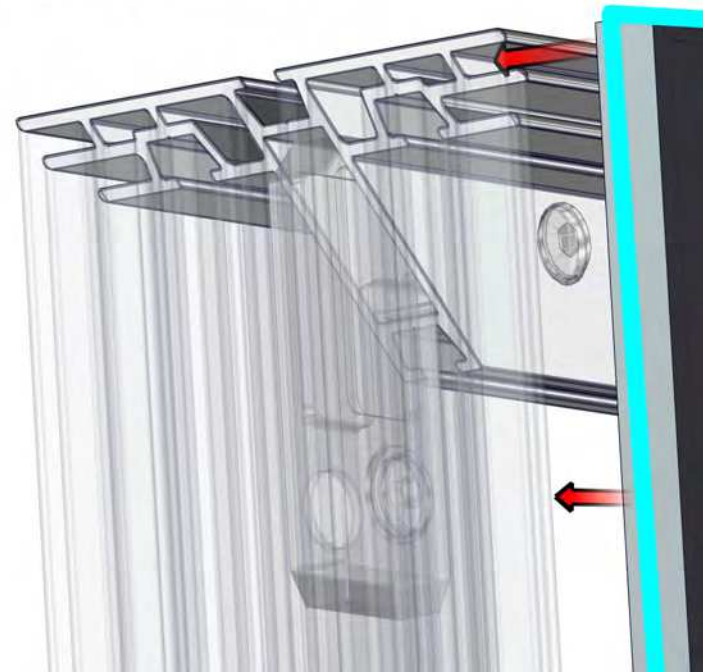

1. Redesign of this exhibit without approval by manufacturer may result in dangerous and unsafe structures. Manufacturer disclaims any responsibility for redesigned exhibits it does not approve in writing.

2. Parts and components such as panels and extrusions are manufactured to metric sizing. Where ever possible sizes have been noted in feet and inches as well as in metric. Below is the imperial to metric sizing table as reference. "Nominal" refers to approximate size.

2400mm = (94 1/2")	Phone Line / Fax
2100mm = (82 5/8")	Internet connection
1800mm = (70 7/8")	Outlet
1500mm = (59")	Main Drop (point of distrution)
1200mm = (47 1/4")	
900mm = (35 1/2")	
600mm = (23 5/8")	
300mm = (11 7/8")	

--- Wire running under carpet

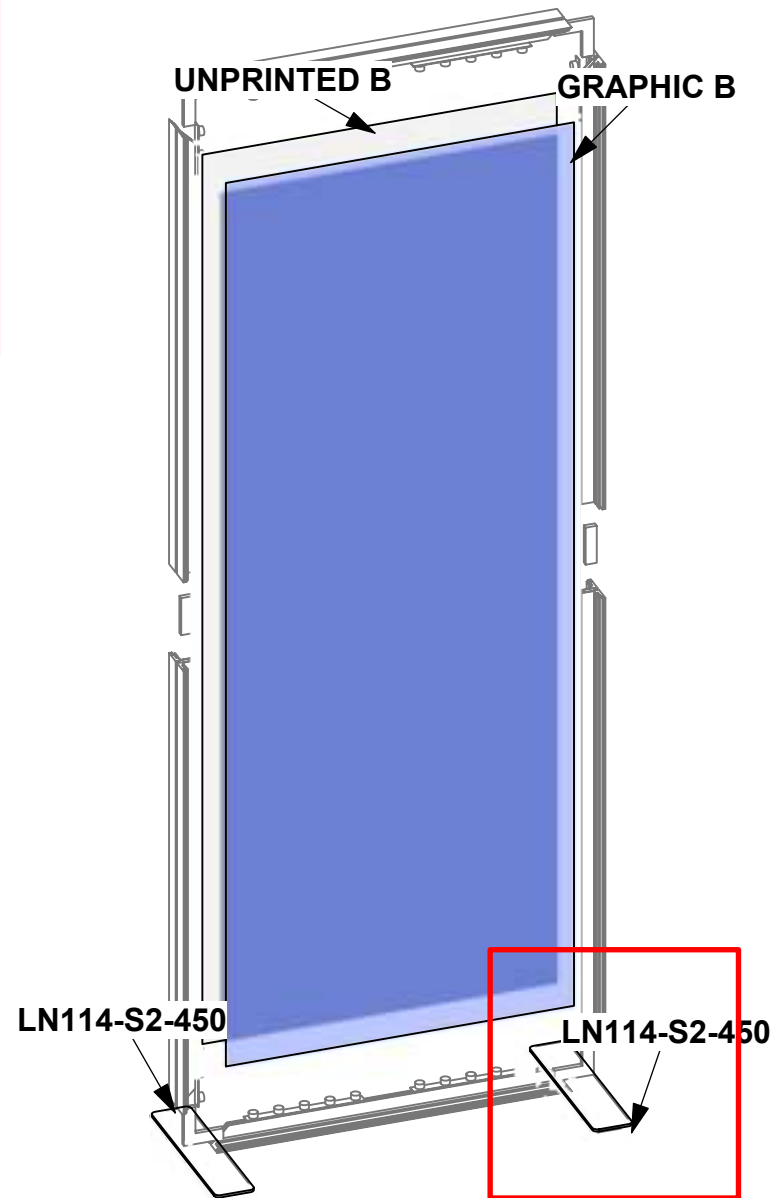
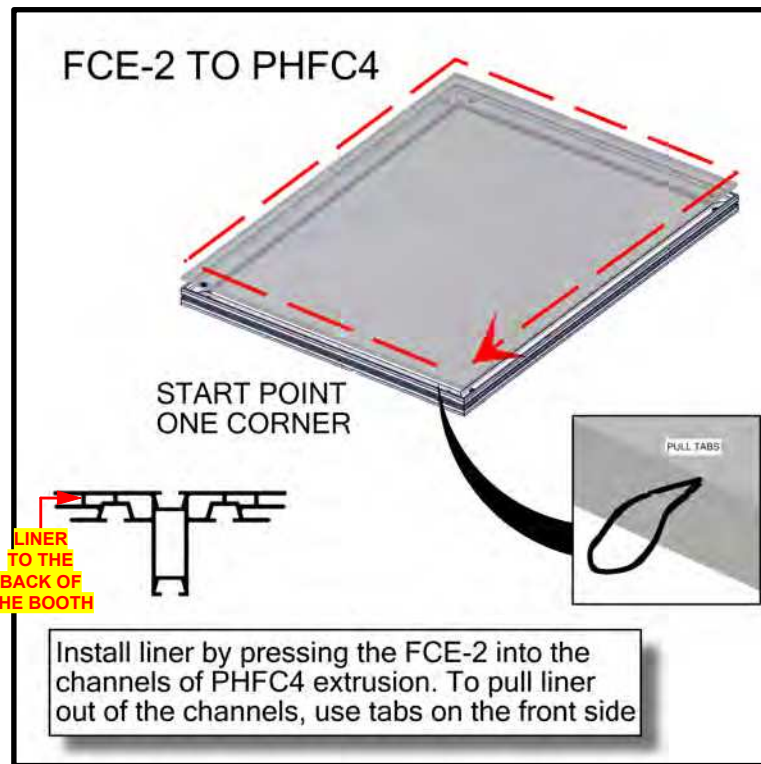
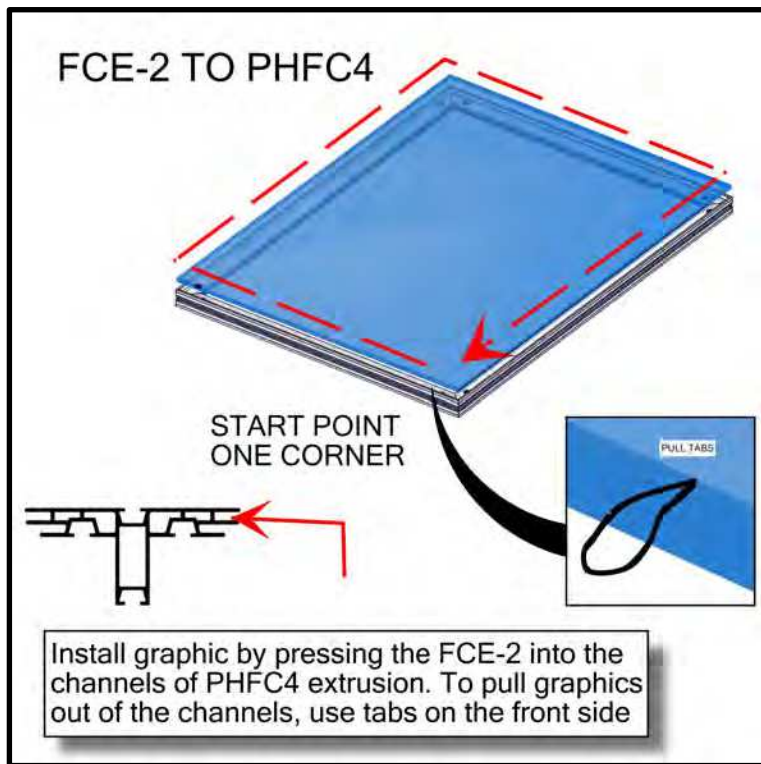
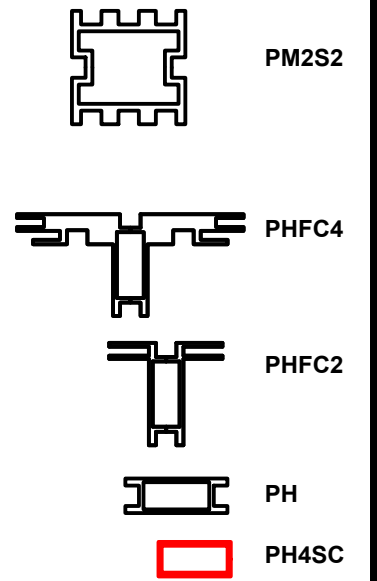

HYBRID PRO RENTAL KIT

Title: SET-UP INSTRUCTIONS

Code	#	Description
CB9-S	8	50MM SQUARE PHCF2 CORNER BRACKET
R20	4	PHFC2-8R-20 EXTRUSION WITH LOCKS 2 ENDS
R19	8	1155MM (45.47") PHFC2 EXTRUSION WITH IB2 HOLE ONE SIDE-WITH LOCK 1 END
IB2	4	INLINE BRACKET CONNECTOR

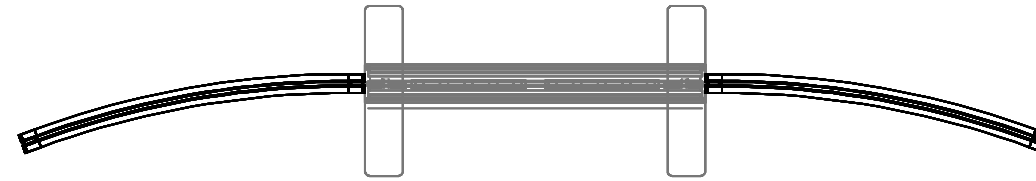

1. Redesign of this exhibit without approval by manufacturer may result in dangerous and unsafe structures. Manufacturer disclaims any responsibility for redesigned exhibits it does not approve in writing.

2. Parts and components such as panels and extrusions are manufactured to metric sizing. Where ever possible sizes have been noted in feet and inches as well as in metric. Below is the imperial to metric sizing table as reference. "Nominal" refers to approximate size.

2400mm = (94 1/2")	Phone Line / Fax
2100mm = (82 5/8")	Internet connection
1800mm = (70 7/8")	Outlet
1500mm = (59")	Main Drop (point of distrution)
1200mm = (47 1/4")	
900mm = (35 1/2")	
600mm = (23 5/8")	
300mm = (11 7/8")	

--- Wire running under carpet

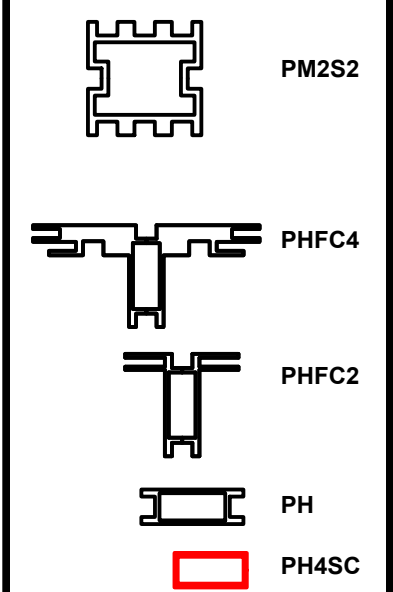
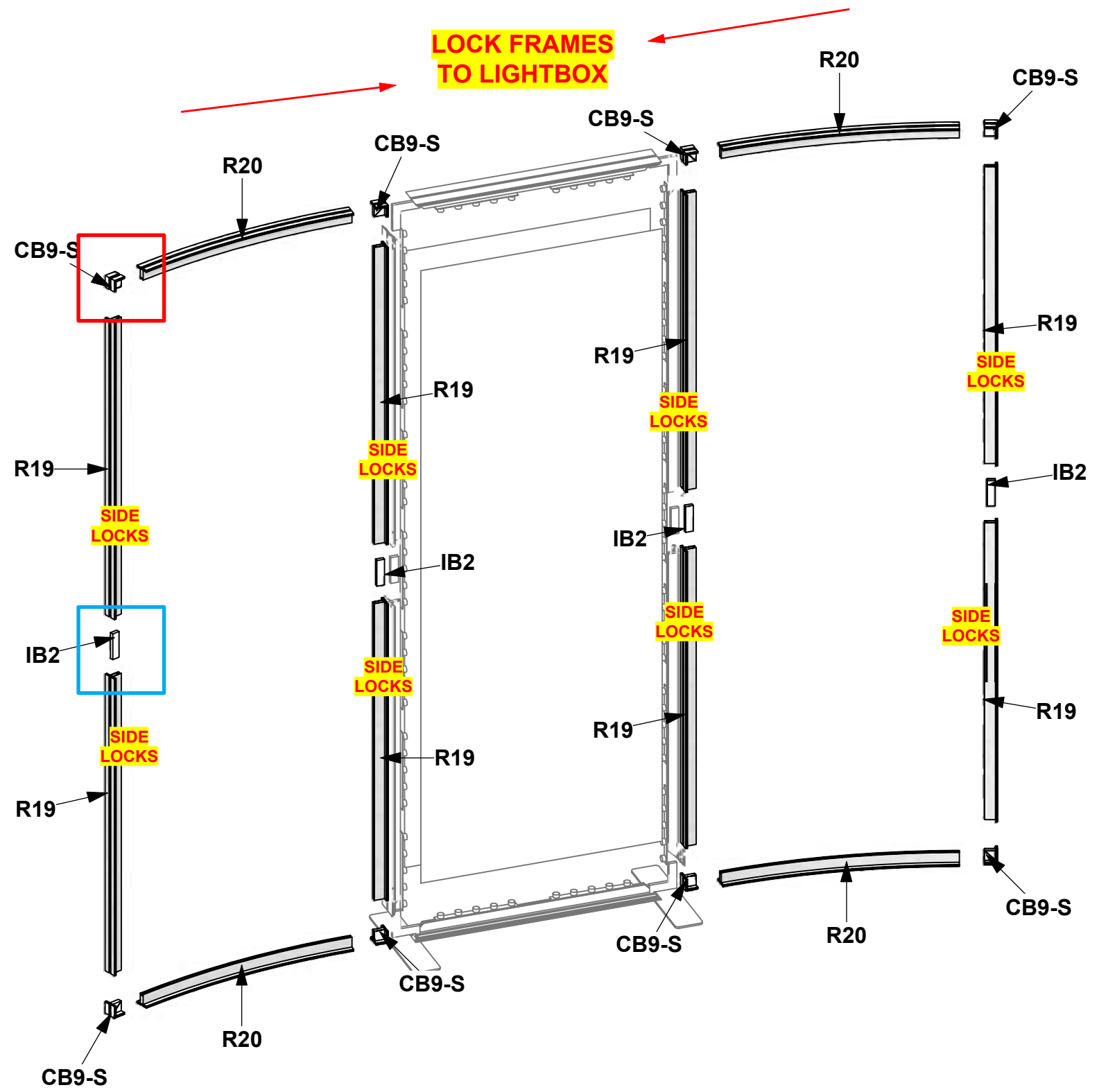
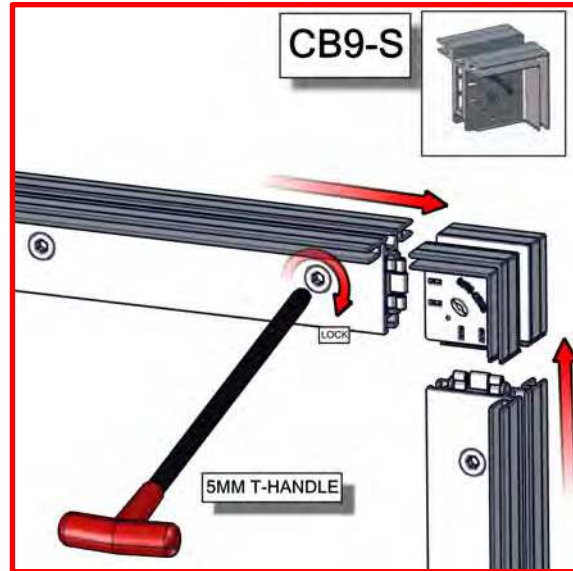

HYBRID PRO RENTAL KIT

Title: SET-UP INSTRUCTIONS

Code	#	Description
GRAPHIC A1	1	94.5"H X 36.182"W SINGLE SIDED DYESUB GRAPHIC W/FCE-2 ON PERIMETER
GRAPHIC A2	1	94.5"H X 36.182"W SINGLE SIDED DYESUB GRAPHIC W/FCE-2 ON PERIMETER

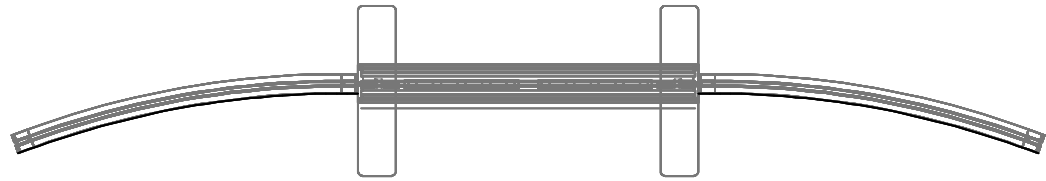



1. Redesign of this exhibit without approval by manufacturer may result in dangerous and unsafe structures. Manufacturer disclaims any responsibility for redesigned exhibits it does not approve in writing.

2. Parts and components such as panels and extrusions are manufactured to metric sizing. Where ever possible sizes have been noted in feet and inches as well as in metric. Below is the imperial to metric sizing table as reference. "Nominal" refers to approximate size.

2400mm = (94 1/2")	Phone Line / Fax
2100mm = (82 5/8")	Internet connection
1800mm = (70 7/8")	Outlet
1500mm = (59")	Main Drop (point of distrution)
1200mm = (47 1/4")	
900mm = (35 1/2")	
600mm = (23 5/8")	
300mm = (11 7/8")	

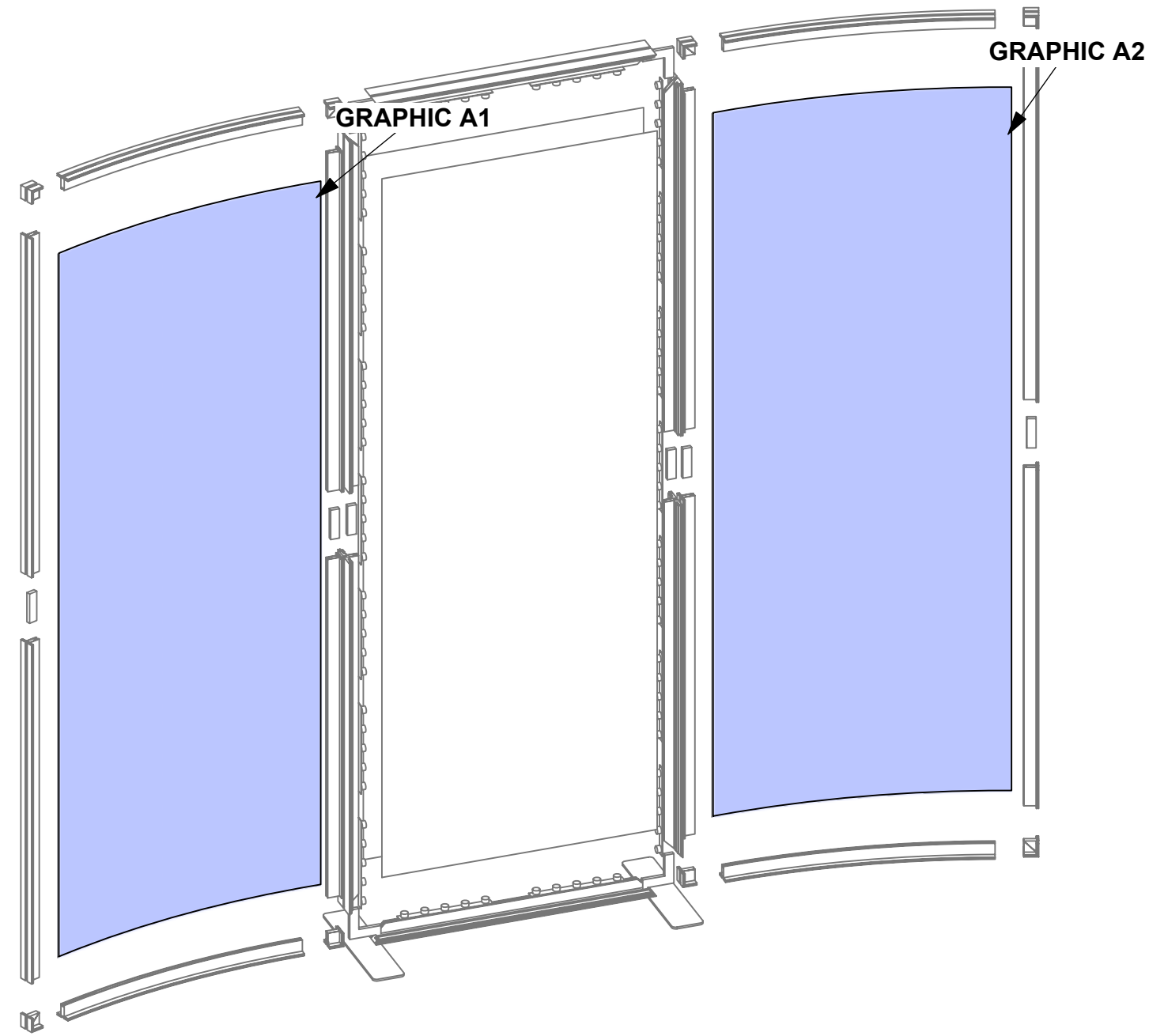
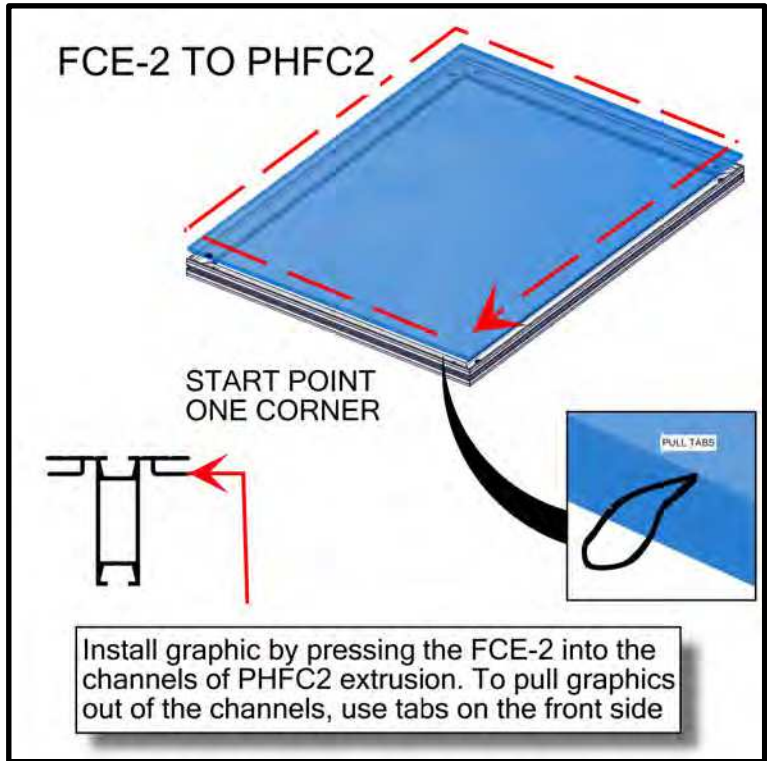
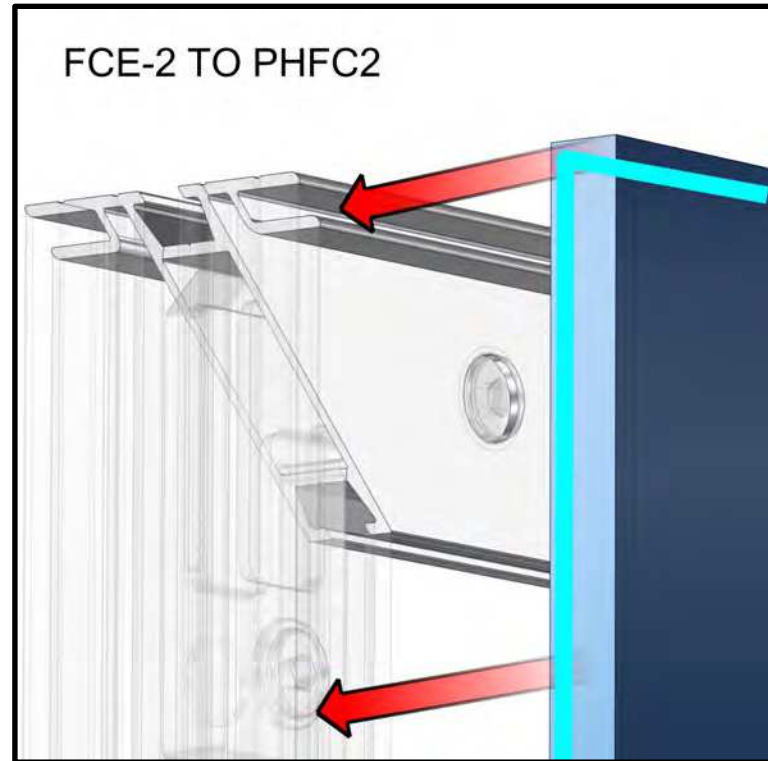
--- Wire running under carpet

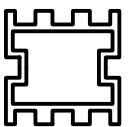
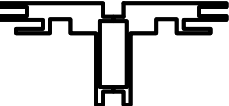
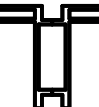

-  PM2S2
-  PHFC4
-  PHFC2
-  PH
-  PH4SC

HYBRID PRO RENTAL KIT

Title: SET-UP INSTRUCTIONS

Code	#	Description
SW-FOOT	2	SMARTWALL SUPPORT FOOT
R15	4	1200MM (47.24") 50MM50MM PM2S SQUARE EXTRUSION WITH STOP AT 155MM
R25	2	PH4SC-300MM (11.81") EXTRUSION WITH TENSION GLIDES

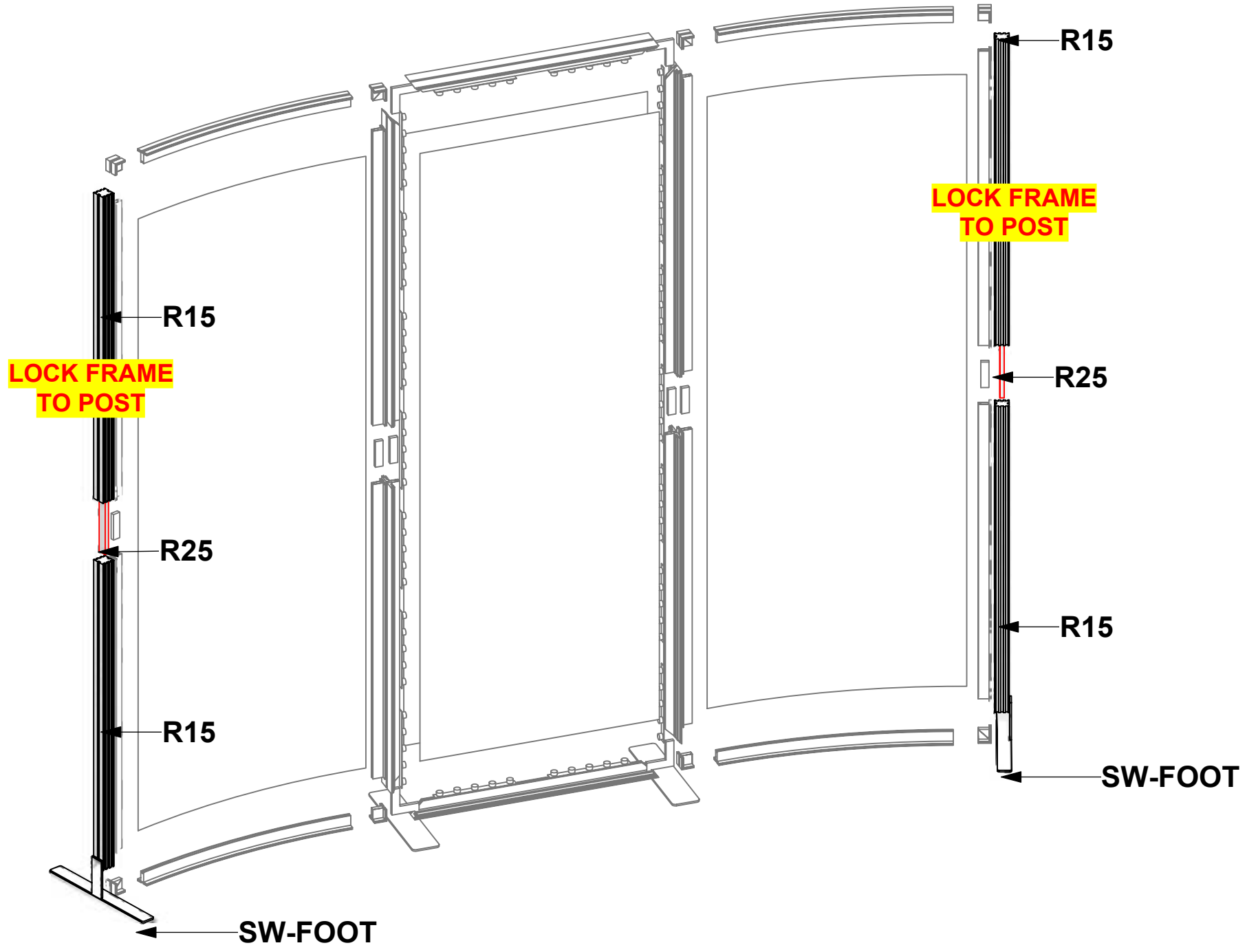
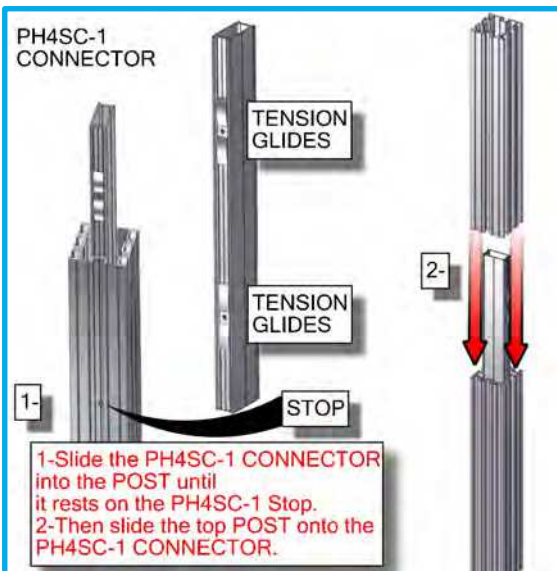
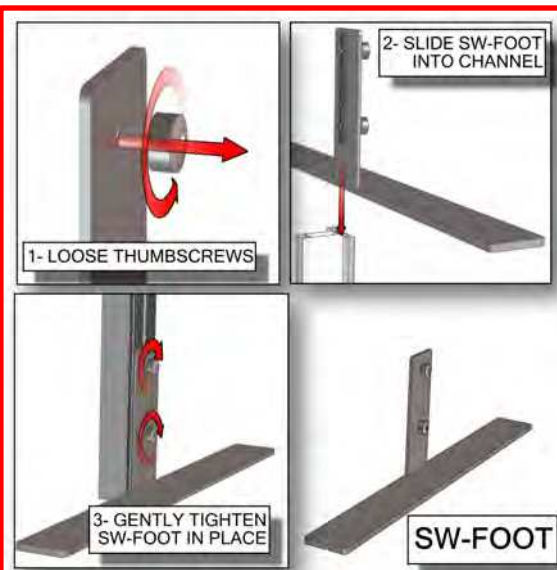

1. Redesign of this exhibit without approval by manufacturer may result in dangerous and unsafe structures. Manufacturer disclaims any responsibility for redesigned exhibits it does not approve in writing.

2. Parts and components such as panels and extrusions are manufactured to metric sizing. Where ever possible sizes have been noted in feet and inches as well as in metric. Below is the imperial to metric sizing table as reference. *Nominal* refers to approximate size.

2400mm = (94 1/2")	☎ Phone Line / Fax
2100mm = (82 5/8")	🌐 Internet connection
1800mm = (70 7/8")	🔌 Outlet
1500mm = (59")	⚡ Main Drop (point of distrution)
1200mm = (47 1/4")	
900mm = (35 1/2")	
600mm = (23 5/8")	
300mm = (11 7/8")	

--- Wire running under carpet

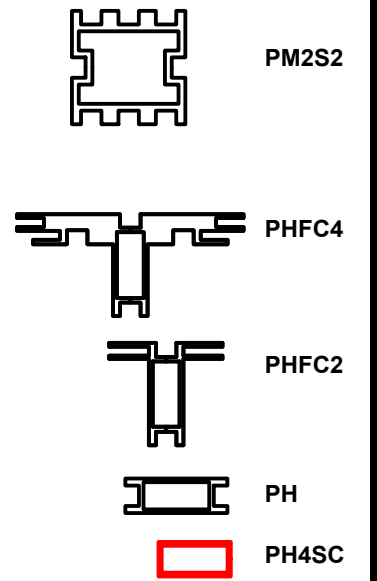

HYBRID PRO RENTAL KIT

Title: SET-UP INSTRUCTIONS

Code	#	Description
V-M-BRACKET-01	2	VM1 MONITOR BRACKET
SM-MB	2	SMALL MONITOR BRACKET
R8	2	300MM (11 13/16") PH WITH SLIDE LOCK AT BOTH ENDS
V-LG-05	2	1005MM X 425MM (39 9/16" X 16 3/4") RECTANGLE LEG 50MM CHANNEL
V-WS-CT-01	2	500MM X 538MM (19 11/16" X 21 3/16") TAPERED WORKSTATION TOP

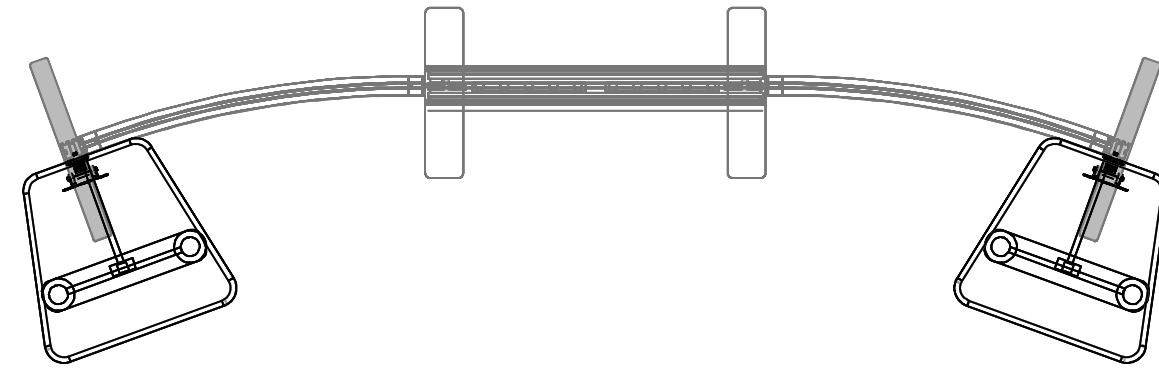

1. Redesign of this exhibit without approval by manufacturer may result in dangerous and unsafe structures. Manufacturer disclaims any responsibility for redesigned exhibits it does not approve in writing.

2. Parts and components such as panels and extrusions are manufactured to metric sizing. Where ever possible sizes have been noted in feet and inches as well as in metric. Below is the imperial to metric sizing table as reference. "Nominal" refers to approximate size.

2400mm = (94 1/2")	Phone Line / Fax
2100mm = (82 5/8")	Internet connection
1800mm = (70 7/8")	Outlet
1500mm = (59")	Main Drop (point of distrution)
1200mm = (47 1/4")	
900mm = (35 1/2")	
600mm = (23 5/8")	
300mm = (11 7/8")	

--- Wire running under carpet

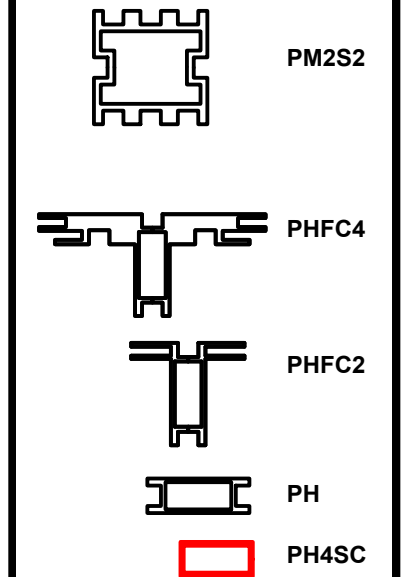
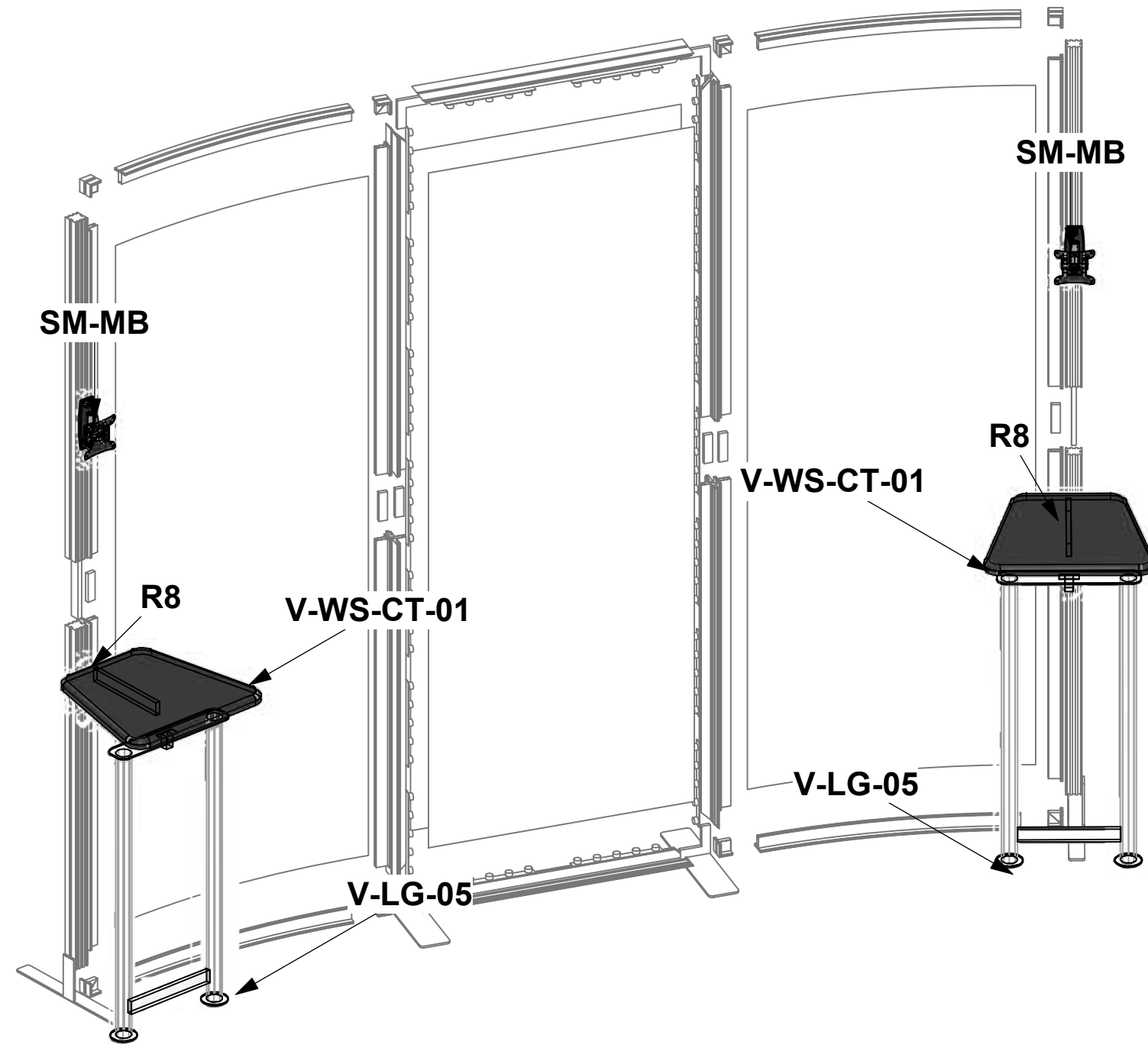
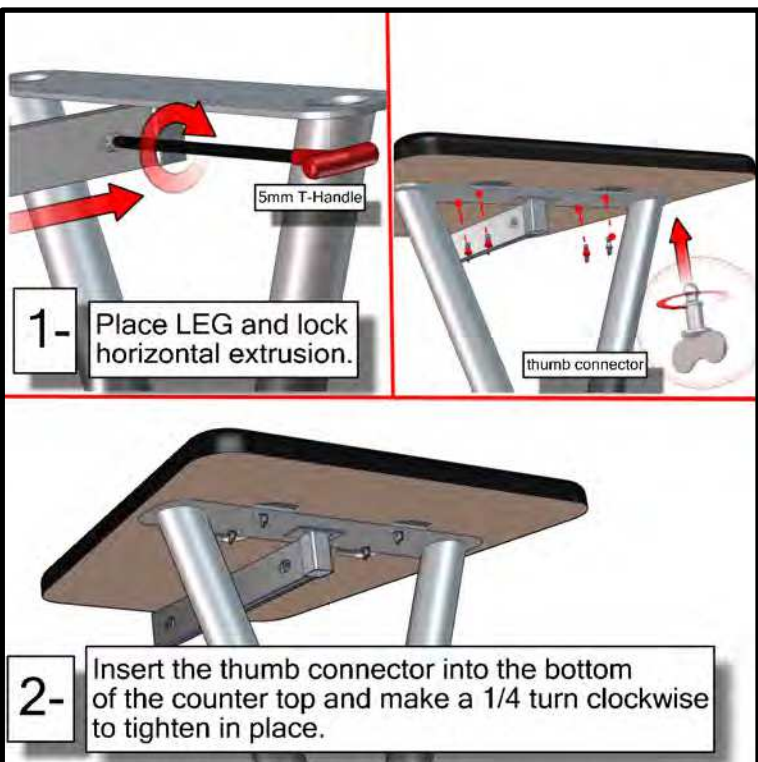
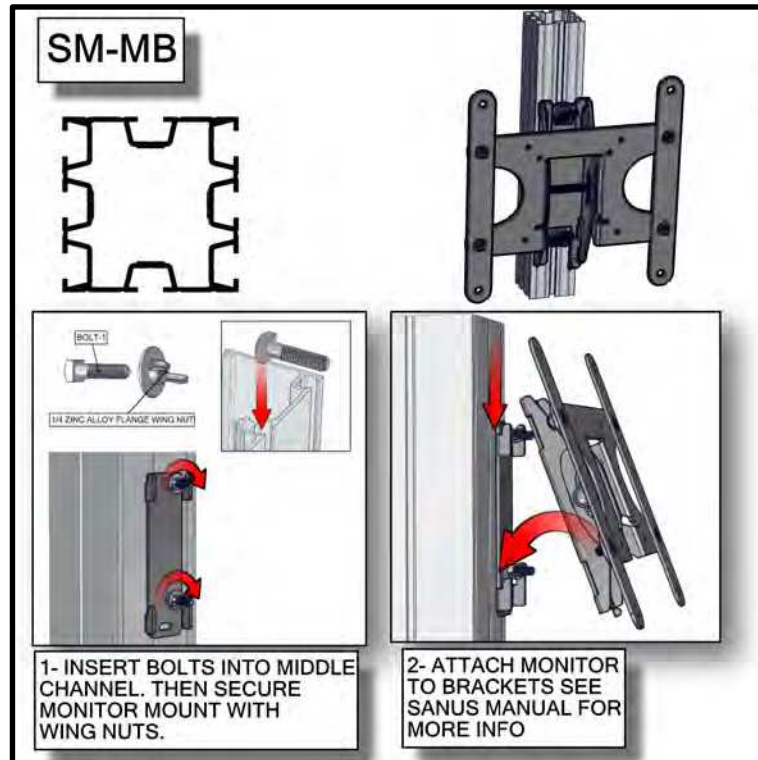

HYBRID PRO RENTAL KIT

Title: SET-UP INSTRUCTIONS

Code	#	Description
LEDL10B	2	LED SPOTLIGHT,3M,UL PLUG W/TRANSFORMER BLACK

1. Redesign of this exhibit without approval by manufacturer may result in dangerous and unsafe structures. Manufacturer disclaims any responsibility for redesigned exhibits it does not approve in writing.

2. Parts and components such as panels and extrusions are manufactured to metric sizing. Where ever possible sizes have been noted in feet and inches as well as in metric. Below is the imperial to metric sizing table as reference. "Nominal" refers to approximate size.

2400mm = (94 1/2")	☎ Phone Line / Fax
2100mm = (82 5/8")	🌐 Internet connection
1800mm = (70 7/8")	🔌 Outlet
1500mm = (59")	⚡ Main Drop (point of distrution)
1200mm = (47 1/4")	
900mm = (35 1/2")	
600mm = (23 5/8")	
300mm = (11 7/8")	

--- Wire running under carpet

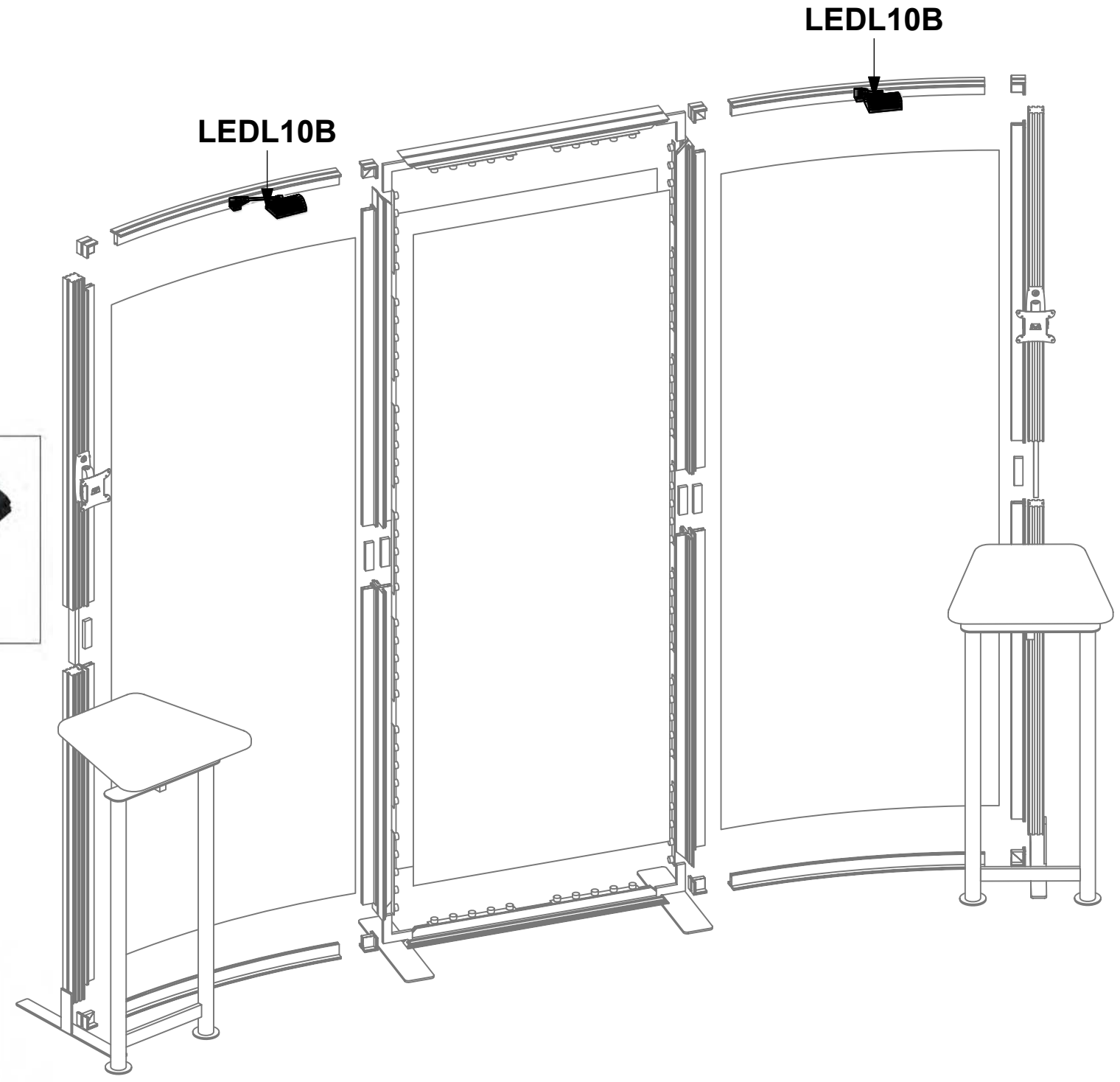
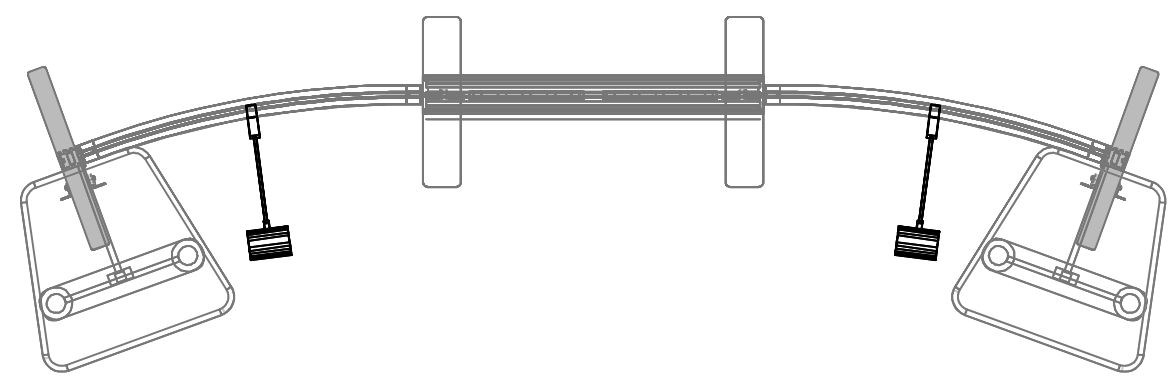

LIGHT



1- Slide light clip onto the LIGHT.
 2-Then slide the LIGHT into the channel at an angle and then gently lower down.

	PM2S2
	PHFC4
	PHFC2
	PH
	PH4SC

HYBRID PRO RENTAL KIT

Title: SET-UP INSTRUCTIONS

PACKING INSTRUCTIONS



1

(2) R25, (2) R8,
(2) R26, (3) R27



2

(4) R20, (4) R15
(8) R19, (2) R25



3

(2) SM-MB, (2) L10 LEDs
(2) LN-114-450, (1) R27,
(2) SW FOOT



HARDWARE KIT



CASE # 1

LEGEND		GREY FOAM FOLDED TO FILL EMPTY SPACES OR USED AS PROTECTION
		1/8" CARDBOARD SPACER (PUT IN BETWEEN EVERY PANEL)
		DIVIDER
		1/4" WHITE FOAM (USED AS PROTECTION DOOR PANELS W/ LOCKS)

INTERNAL DIMS 48.25"L X 24"W X 14"H
EXTERNAL DIMS 51.5"L X 29"W X 14.5"H





1

EMPTY TRAY



2

(1) V-WS-CT-01



3

(1) V-WS-CT-01



4

(2) V-LG-05

CASE # 2

LEGEND		GREY FOAM FOLDED TO FILL EMPTY SPACES OR USED AS PROTECTION
		1/8" CARDBOARD SPACER (PUT IN BETWEEN EVERY PANEL)
		DIVIDER
		1/4" WHITE FOAM (USED AS PROTECTION DOOR PANELS W/ LOCKS)

