

Parts included	
Part Label	Qty
Upper frame	x1
Lower frame	x1
Joiner	x4
Base plates	x2
Base	x1
Monitor bracket	x1

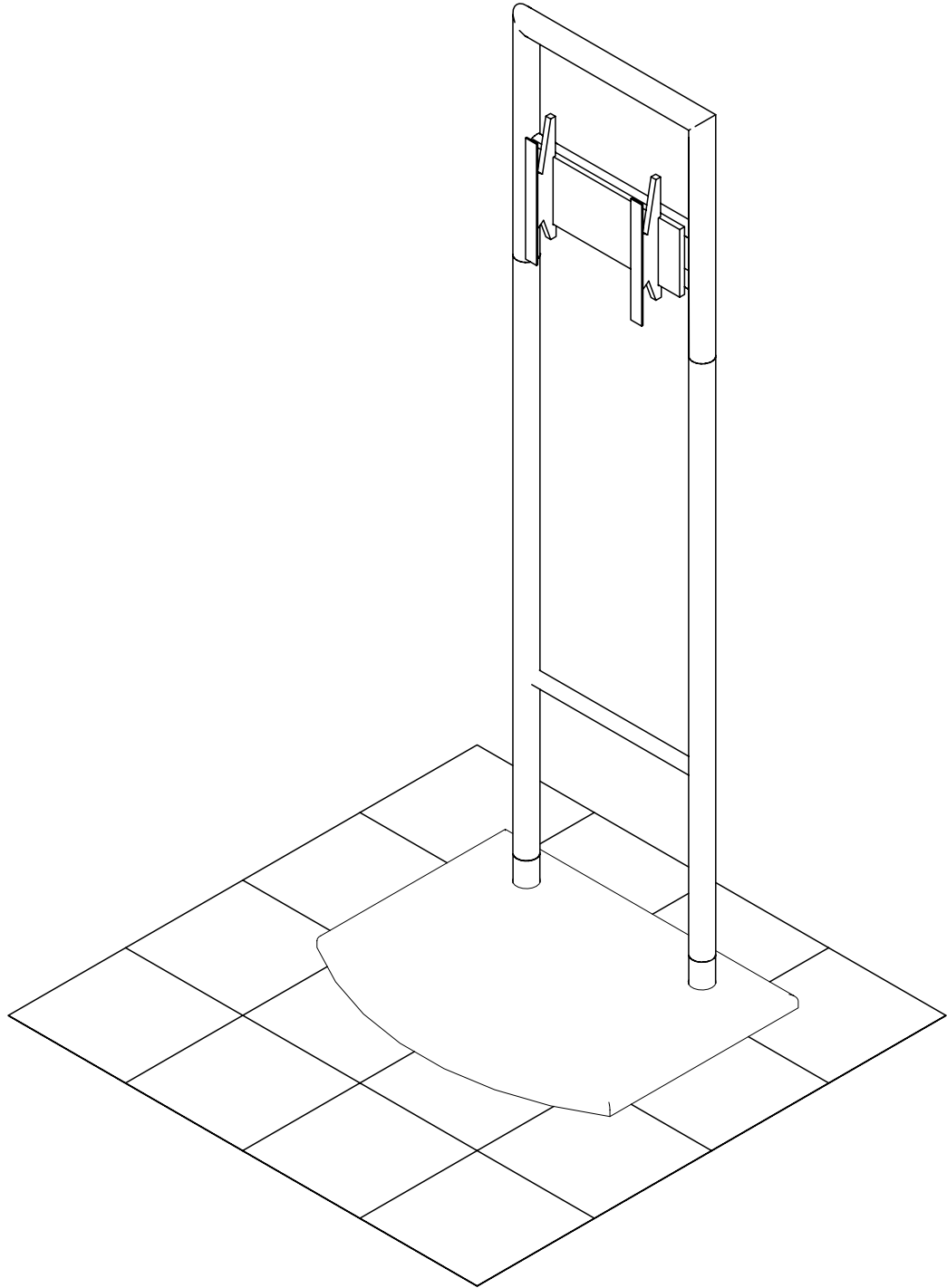

Step 1.

Connect the plates to the base using four screws per plate as shown in the attachment detail below. Assure holes on tubing are facing inward.

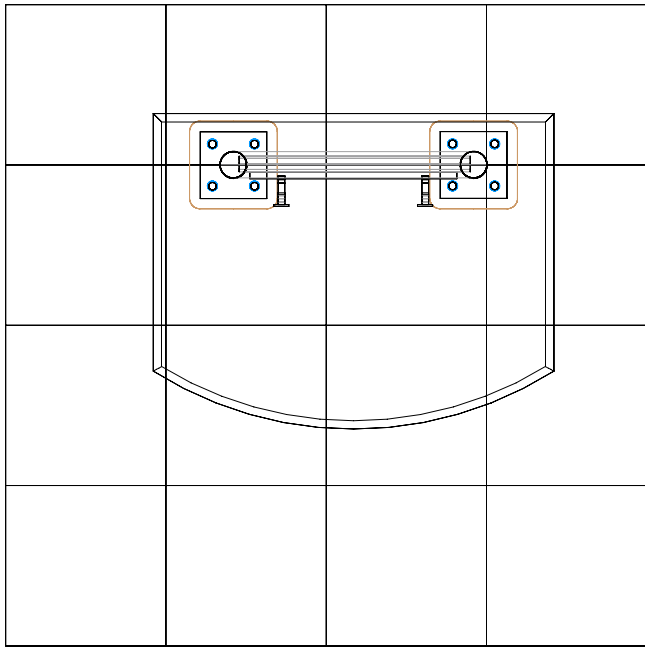
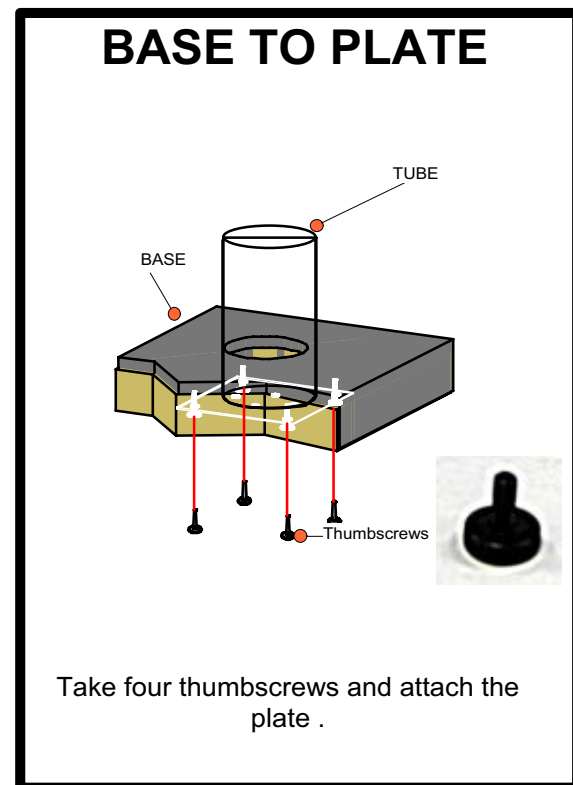
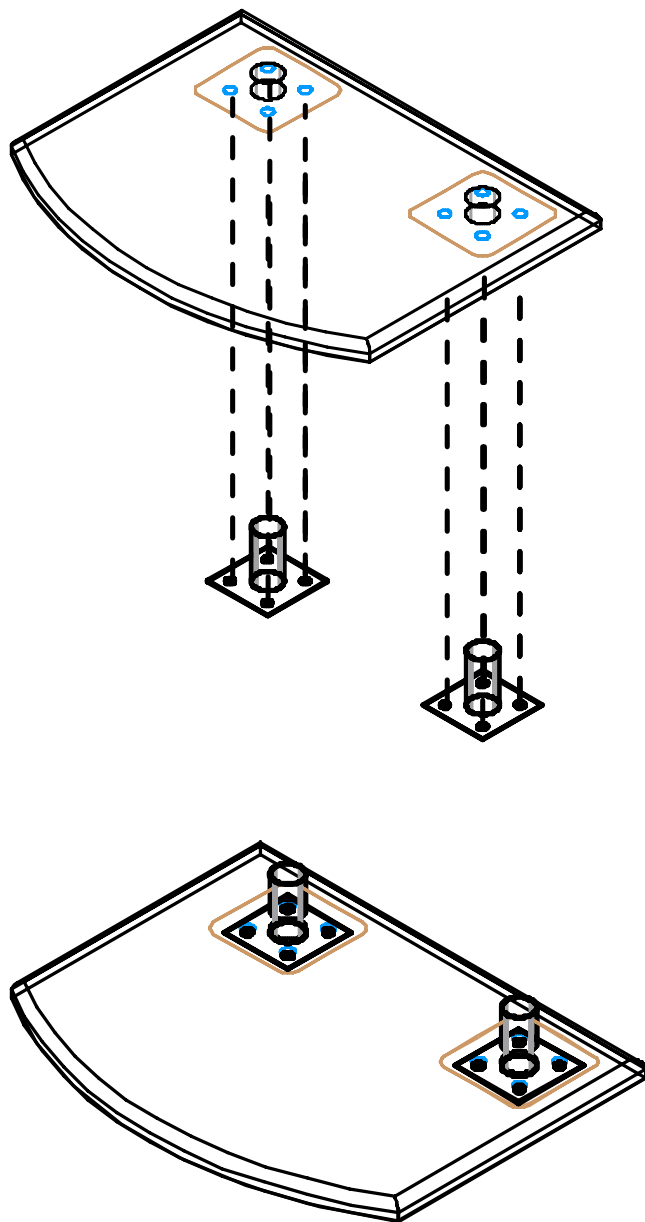

## Step 2.

Attach the lower frame to the base plates at points 1A and 2A following the labels. Use the joiner to connect as shown in the attachment detail below. Attach the upper frame to the lower frame at points 3A and 4A following the labels. Use the joiner to connect as shown in the attachment detail below.

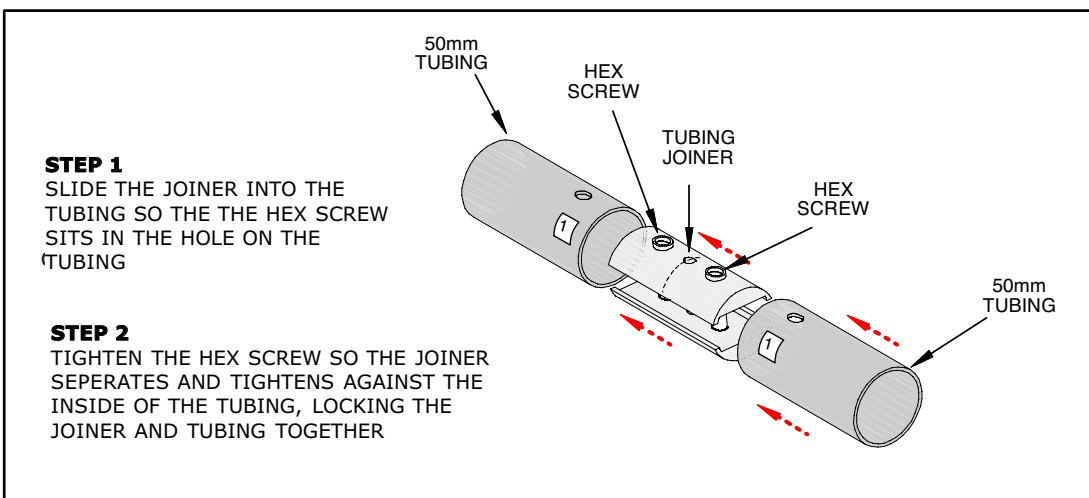
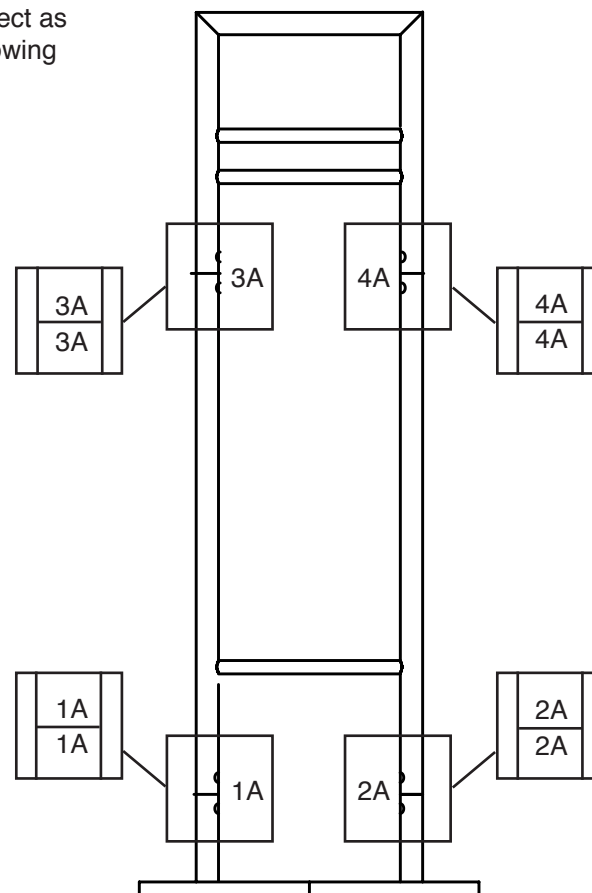
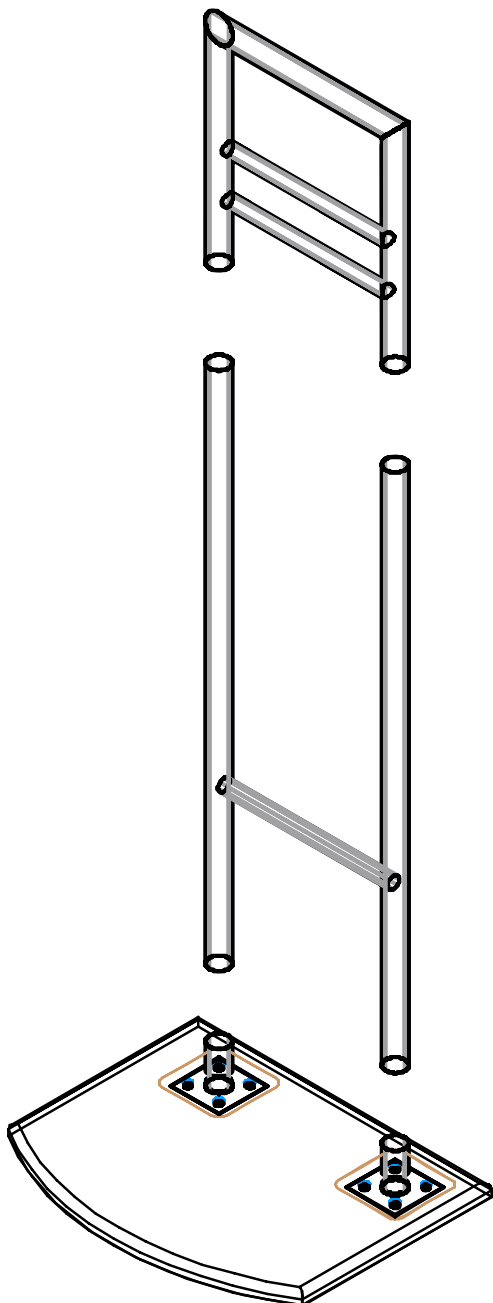

### Step 3.

To attach the monitor mount, put square head bolts through the back of the pre-drilled tube. Slide monitor mount onto bolts and secure with wingnuts. Position mount where desired.

