

# Formulate 10' Four Sided Tower

## COL-02

Mix and match the Formulate™ line of towers to add architecture and drama to any event or interior space. Rectangular-shaped towers come in 12ft, 10ft and 8ft heights and 3ft square at the top and bottom. They combine the latest developments in fabric printed technology with aluminum tube frames to add dimension, decor and sculpture to any event, stage set, tradeshow booth or interior space. Formulate towers accommodate internal LED lighting to create a glowing effect.

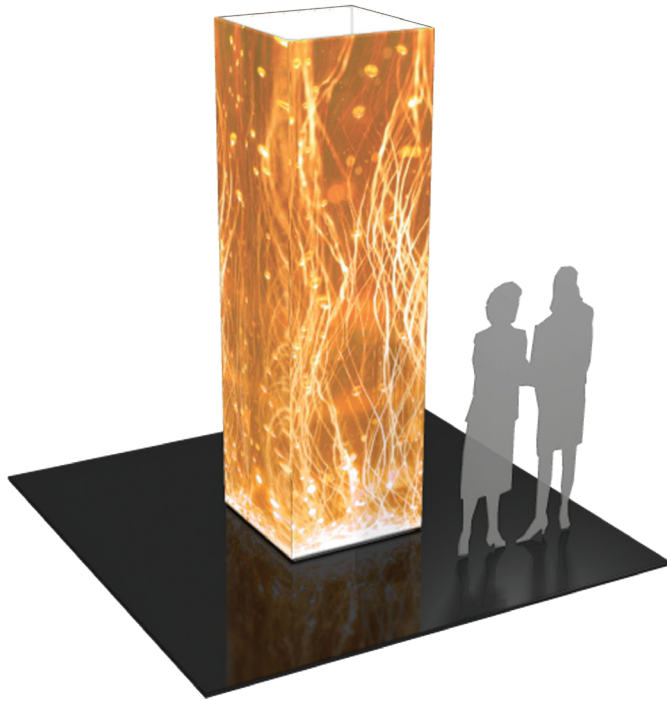

## features and benefits:

- State-of-the-art 30mm aluminum tube frame with snap button assembly
- Easy to store and ship
- Quick to set up
- Kit includes: one frame, one dye-sublimated zipper pillowcase graphic, and one wheeled molded OCL storage case
- Lifetime hardware warranty against manufacturer defects

## dimensions:

Hardware	Graphic
<p>Assembled unit: 36"l x 36"w x 120"h</p> <p>Approximate weight (includes graphic): 28.05 lbs / 12.72 kg</p>	<p>Total visual area: 36"w x 120"h, four prints</p> <p>Please be sure to include 5" bleed around the perimeter.</p>
Shipping	
<p>Shipping dimensions: 1 OCL case: 19"l x 19"w x 56"h 483mm(l) x 483mm(w) x 1422mm(h)</p> <p>Approximate shipping weight (with case): 48.05 lbs / 21.8 kg</p>	

## additional information:

Graphic material:  
dye-sublimated zipper pillowcase graphic with opaque liner

### Parts Included

Part Label	Qty	Part Code
760MM X 30MM TUBE	x8	COL-T1
1130MM X 30MM TUBE	x8	COL-T2
607MM X 30MM TUBE WITH PART C	x4	COL-T3
30MM CURVED SPREADER	x4	COL-T4
TC-30-A ASSEMBLED AT 90°	x8	TC-30-A-90°
10' FOUR SIDED TOWER GRAPHIC	x1	COL-02-G

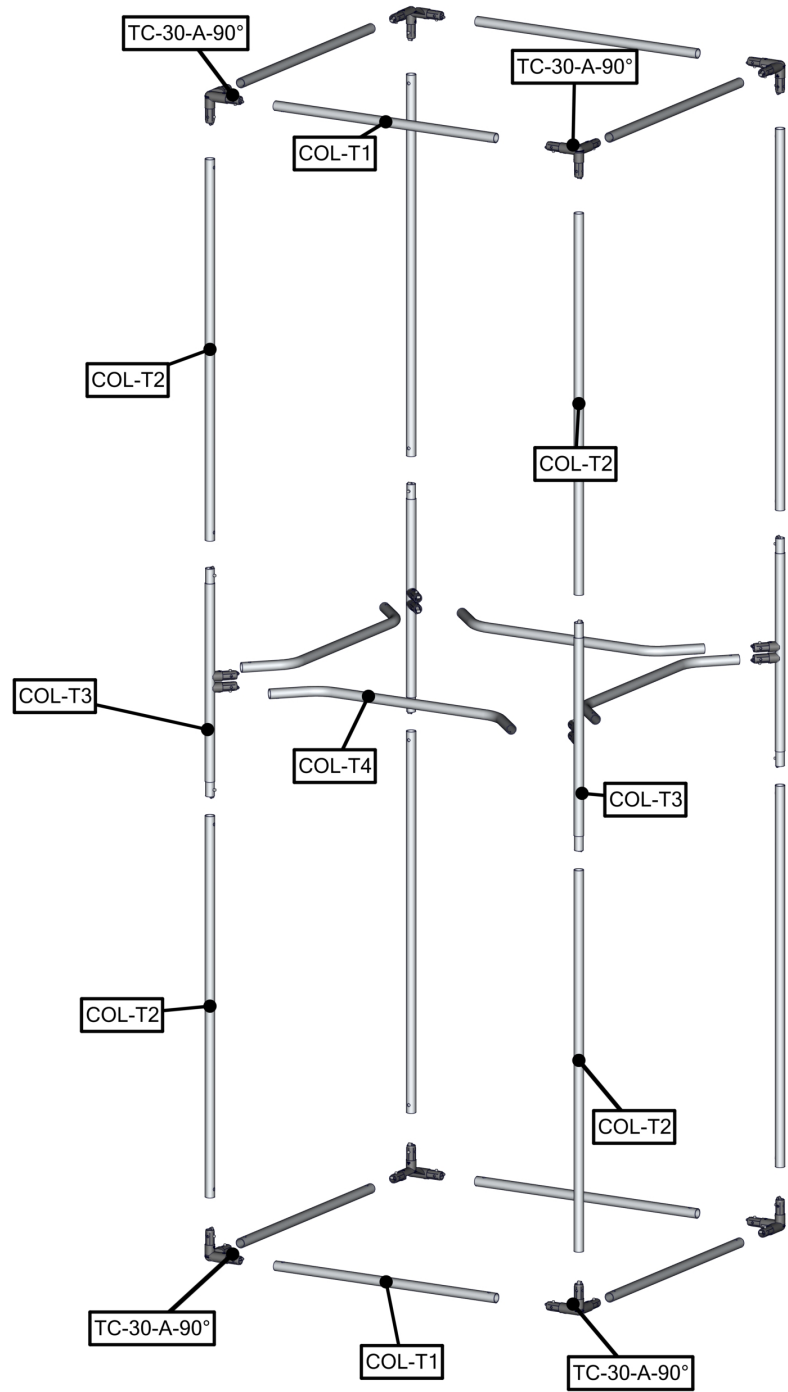

## STEP 1: ASSEMBLE FRAME

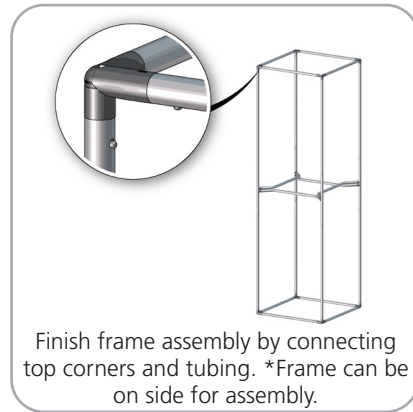
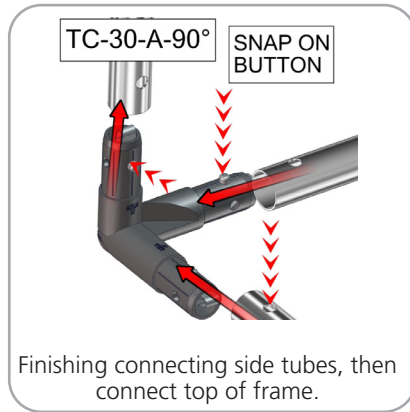
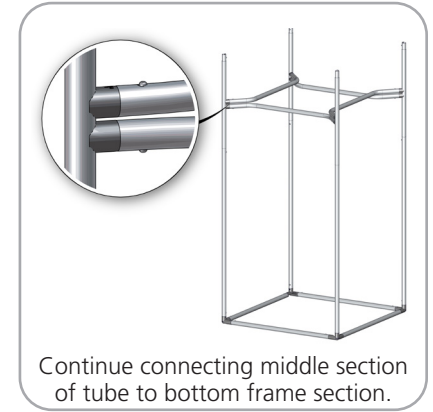
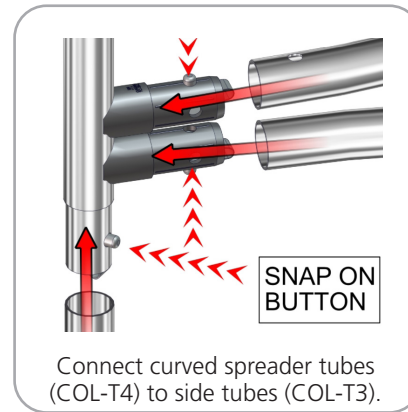
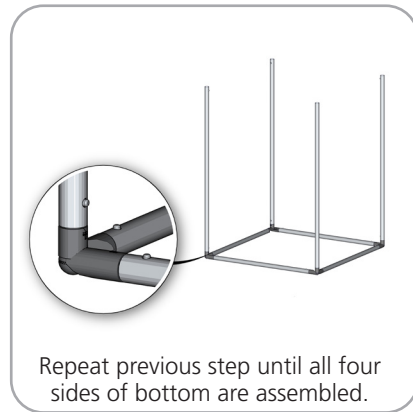
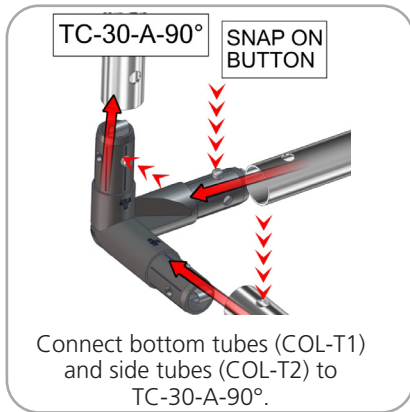

## STEP 2: ATTACH GRAPHIC

