

TRTG-1004

SET UP INSTRUCTIONS:

1. CONNECT BOTTOM AND TOP RAILS FOLLOWING THE LABELS
2. CONNECT SIDE RAILS
3. CLEAN THE FRAME AND PLACE THEM ON CLEAN PLACE
4. CAREFULLY REMOVE FABRIC COVER FROM BAGS
5. PLACE COVER AROUND THE BOTTOM OF THE FRAME
6. PULL COVER CAREFULLY UP TO THE TOP
7. CLOSE ALL ZIPPERS
8. ADJUST FABRIC AROUND THE FRAME

BREAK DOWN INSTRUCTIONS:

REVERSE SET-UP STEPS TO BREAKDOWN FRAME

FABRIC CARE INSTRUCTIONS:

1. UNZIP COVER ZIPPERS
2. CAREFULLY REMOVE FABRIC COVER
3. CLOSE ALL ZIPPERS
4. FOLD OR ROLL NEATLY
5. PLACE FABRIC IN COVER BAG

PART LIST:

PER UNIT

- | | |
|----|----------------------------|
| 24 | 30MM DIA. TUBE SECTIONS |
| 2 | ES-30 EXPANDING SPIGOT |
| 1 | 2.5MM HEX KEY |
| 5 | 5-3/16" THREADED CONNECTOR |
| 4 | 1/4-20 EYE BOLTS |
| 5 | STEEL WIRE ROPE |
| 1 | FABRIC COVER |

Frame Assembly

Assemble frame as shown

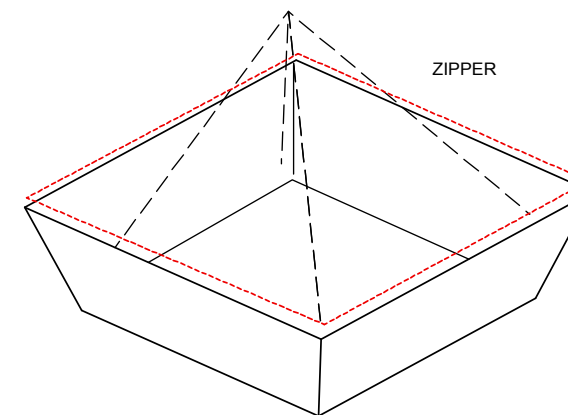
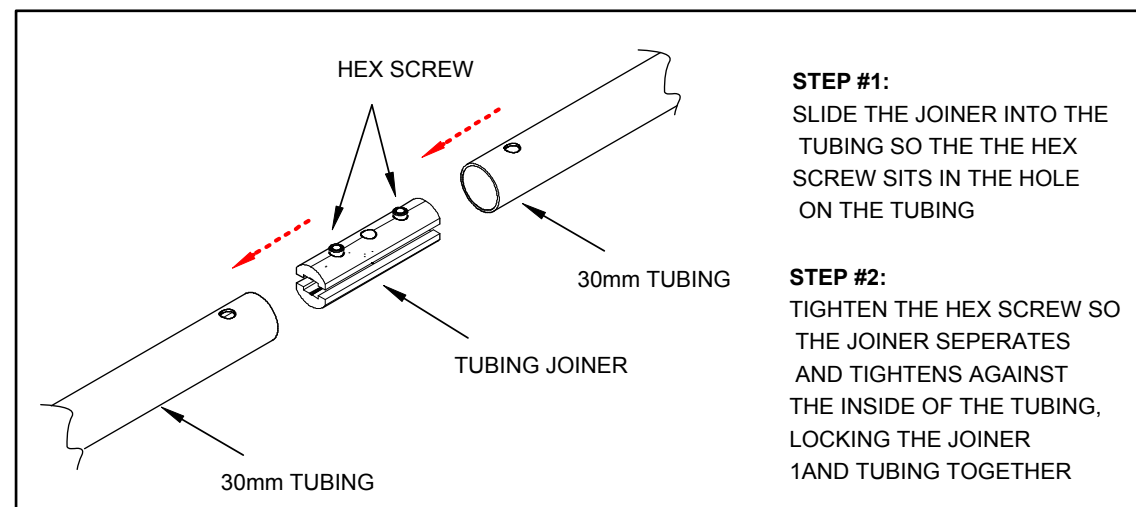
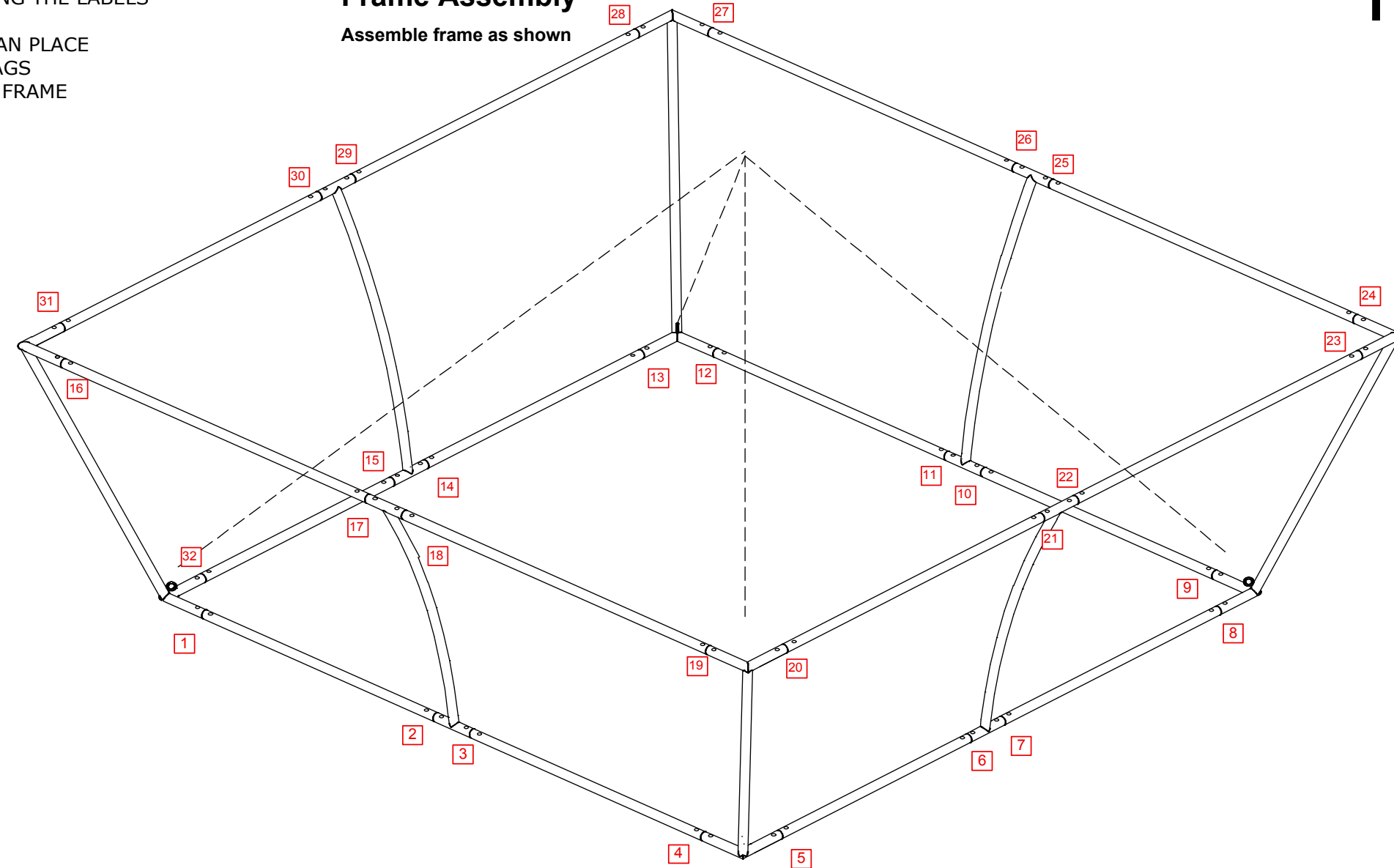

Fabric Cover
SEE EPS TEMPLATE
Fabric: 4417
Add a 2" bleed on all sides
PILLOWCASE CONSTRUCTION