

# Formulate 10' Cylinder Tower

## CYL-02

Mix and match the Formulate™ line of towers to add architecture and drama to any event or interior space. Cylinder-shaped towers come in 12ft, 10ft and 8ft heights and 3ft diameters at the top and bottom. They combine the latest developments in fabric printed technology with aluminum tube frames to add dimension, decor and sculpture to any event, stage set, tradeshow booth or interior space. Formulate towers accommodate internal LED lighting to create a glowing effect.

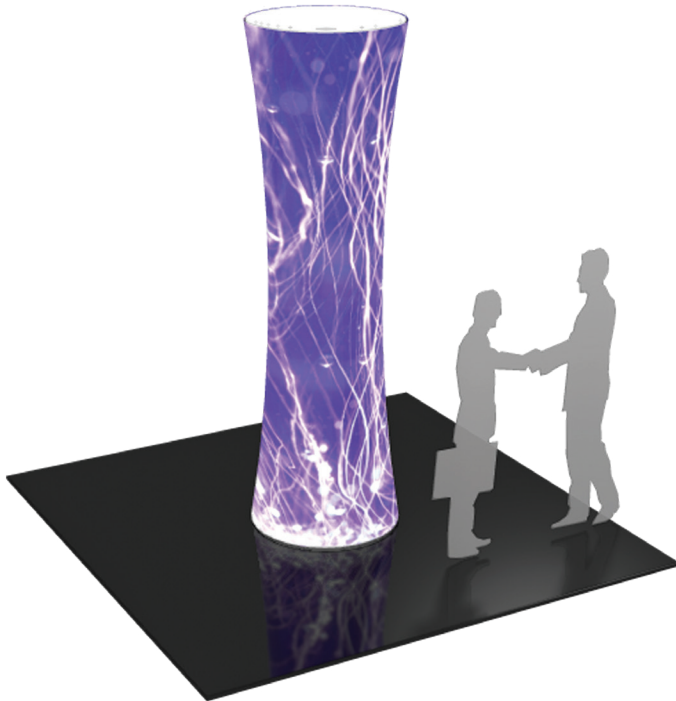

## features and benefits:

- State-of-the-art 30mm aluminum tube frame with snap button assembly
- Easy to store and ship
- Quick to set up
- Kit includes: one frame, one dye-sublimated zipper pillowcase graphic, and one wheeled molded OCL storage case
- Lifetime hardware warranty against manufacturer defects

## dimensions:

Hardware	Graphic
<p>Assembled unit: 36" dia x 120"h 914mm(dia) x 3048mm(h)</p> <p>Approximate weight (includes graphic): 33.6 lbs / 15.24 kg</p>	<p>Total visual area: 56.52"w x 120"h, two prints 1436mm(w) x 3048mm(h)</p> <p>Please be sure to include 5" bleed around the perimeter.</p>
Shipping	
<p>Shipping dimensions: One OCL case: 19"l x 19"w x 56"h 483mm(l) x 483mm(w) x 1422mm(h)</p> <p>Approximate shipping weight (with case): 53.6 lbs / 24.3 kg</p>	

## additional information:

Graphic material:  
dye-sublimated zipper pillowcase graphic with opaque liner

Parts Included		
Part Label	Qty	Part Code
R13015MM X 30MM CURVED TUBE	x3	CYL-02-T1
10' GRAPHIC PILLOWCASE	x1	CYL-02-G
R442MM X 30MM CURVED TUBE WITH SWAGED END AND PART C LEFT SIDE	x3	CYL-T1-R
R442MM X 30MM CURVED TUBE WITH SWAGED END AND PART C RIGHT SIDE	x3	CYL-T1-L
R13015MM X 30MM CURVED TUBE	x6	CYL-T2
INLINE CONNECTOR FOR 30MM TUBING	x6	TC-30-S

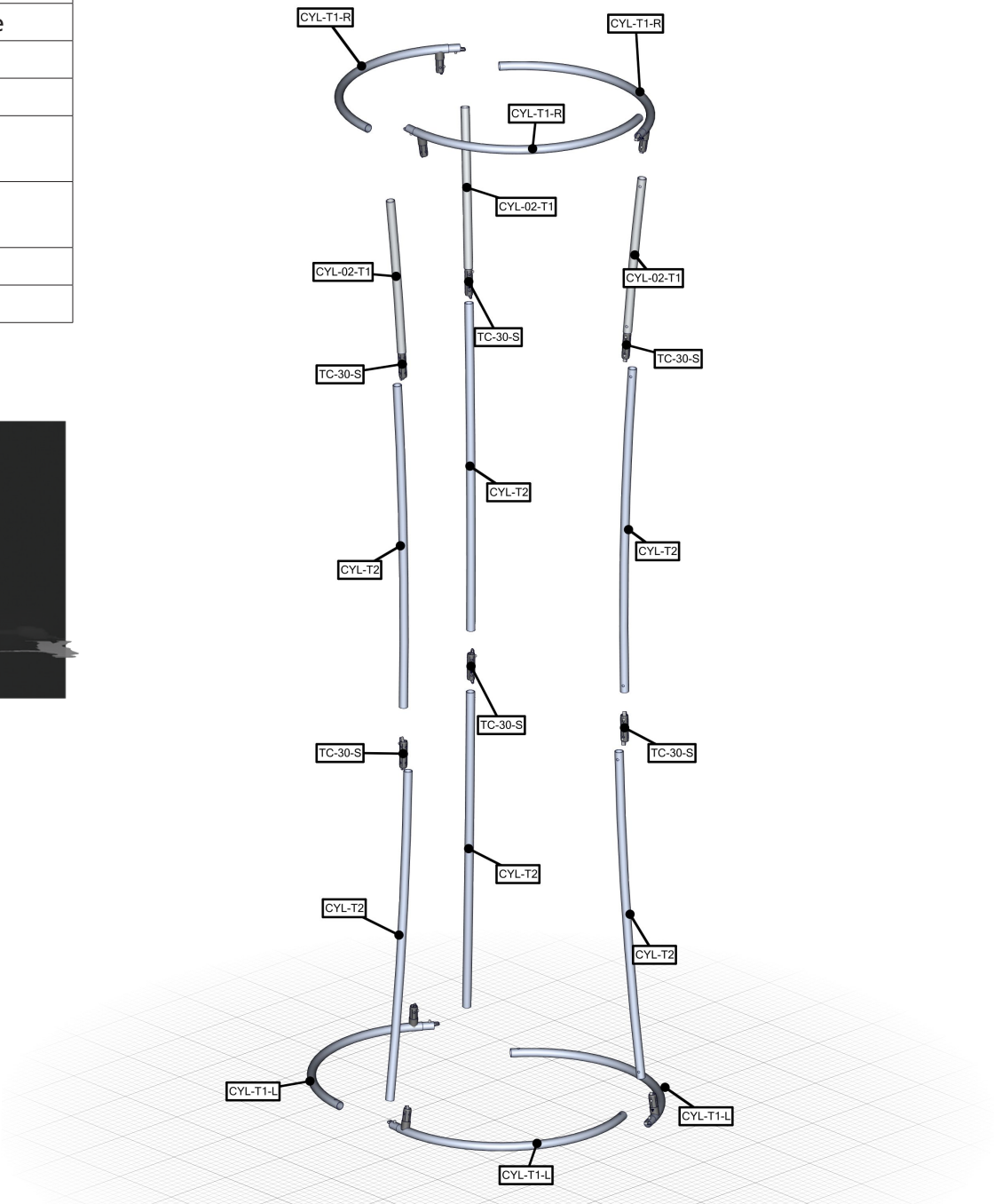
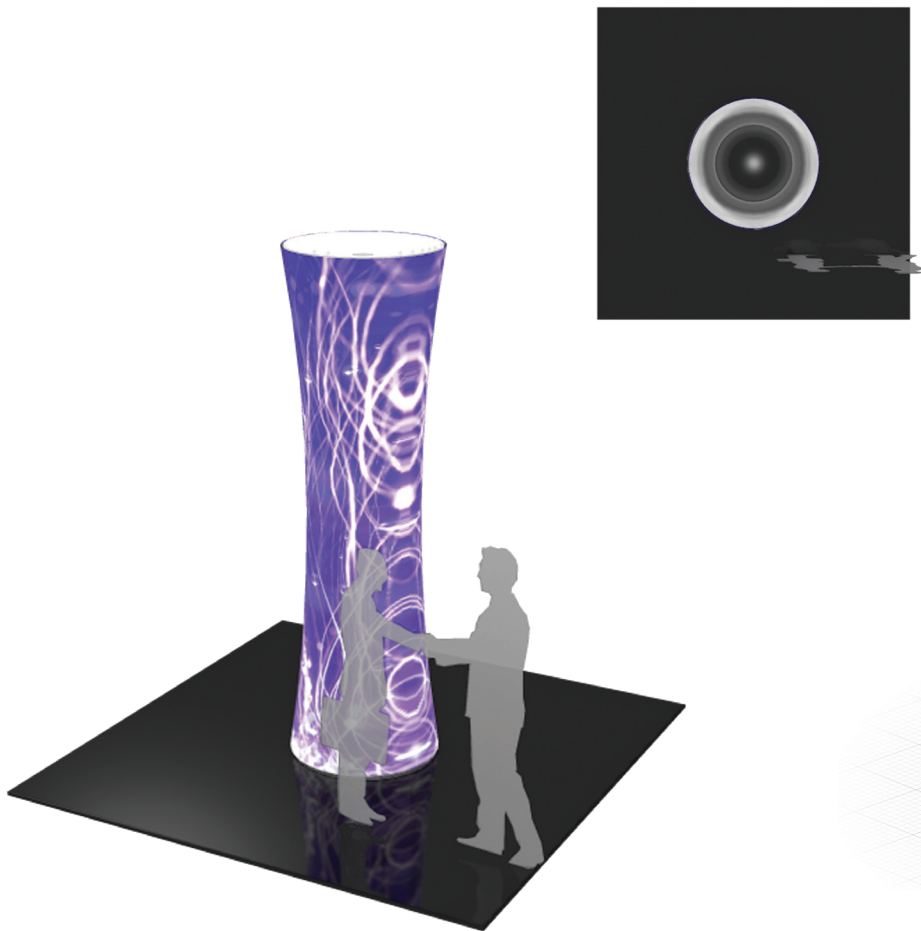

## STEP 1: ASSEMBLE FRAME

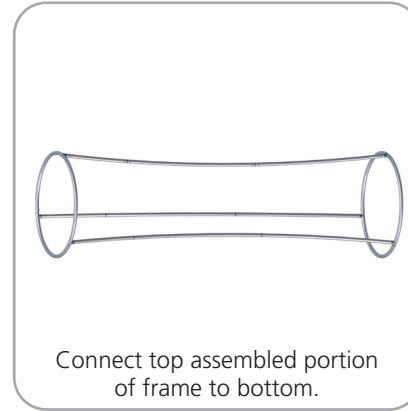
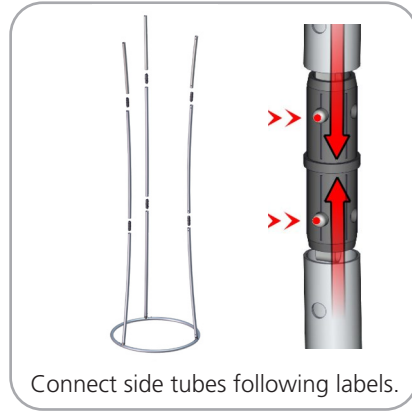
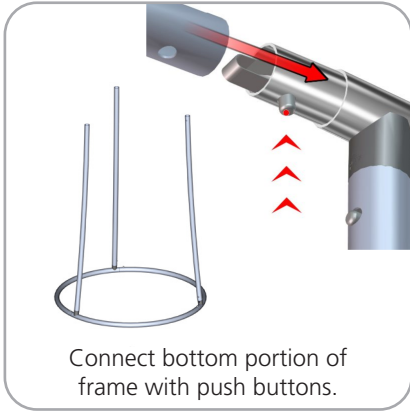

## STEP 2: ATTACH GRAPHIC

