

Formulate 20' Vertical Curve

FMLT-WV20-01

Formulate™ is a collection of sophisticated, ergonomically designed exhibit booths. Formulate combines state-of-the-art zipper pillowcase dye-sublimated fabric coverings with advanced lightweight aluminum structures to provide unique design, functionality, and style. The excellence of the Formulate line of displays, hanging structures and products is simply unmatched. Stretch fabric graphics are hand-sewn, durable and dry-cleanable.



features and benefits:

- State-of-the-art 30mm aluminum tubing with push-button connectors
- Easy to store and ship
- Frame can also be configured* as a standard 10' backwall (*requires additional 10' graphic purchase)
- Kit includes: one frame, one dye-sublimated zipper pillowcase graphic, and two wheeled molded OCL storage cases
- Lifetime hardware warranty against manufacturer defects

dimensions:

Hardware	Graphic
<p>Assembled unit: 232" w x 92.27" h x 24" d 5893mm(w) x 2344mm(h) x 610mm(d)</p> <p>Approximate weight (includes graphic): 110 lbs / 50 kgs</p>	<p>Total visual area: 232" w x 94.5" h 5893mm(w) x 2400mm(h)</p> <p>Please be sure to include a 2" bleed around the perimeter.</p> <p>Refer to related graphic template for more information.</p>
<p>Shipping</p> <p>Shipping dimensions: 2 OCL cases: 19" l x 19" w x 56" h 483mm(l) x 483mm(w) x 1422mm(h)</p> <p>Approximate shipping weight (with cases): 150 lbs / 68 kgs</p>	

additional information:

Graphic material:
Dye-sublimated zipper pillowcase fabric

Optional accessories:
Lumina 8-50 watt halogen lighting, literature pocket, stand-off literature rack, stand-off graphic shelf, graphic header, larger freight cases

We are continually improving and modifying our product range and reserve the right to vary the specifications without prior notice. All dimensions and weights quoted are approximate and we accept no responsibility for variance. E&OE. See Graphic Templates for graphic bleed specifications.

Parts Included		
Part Label	Qty	Part Code
1270MM X 30MM TUBE	x12	WV10-01-T1
R2250 (1163MM ARC) CURVED TUBE	x7	WV10-01-T2
30MM CURVED TUBE WITH PART T AND 90B LEFT SIDE	x1	WV10-01-T2-L
30MM CURVED TUBE WITH PART T AND 90B RIGHT SIDE	x1	WV10-01-T2-R
(2)128MM TUBES SWAGED WITH PART TC-30-T	x2	WV10-01-04
(2)128MM TUBES SWAGED WITH PART TC-30-T	x2	WV10-01-T7
(2) 128MM TUBES SWAGED WITH PART TC-30-X	x2	WV10-01-T5
R2250 X 30MM TUBE WITH WELDED SWAGE RIGHT SIDE	x1	WV10-01-T6-PART C
30MM LEG TUBE WITH LEVELING FOOT	x1	WV10-01-T7-V2
(2) 67MM TUBES SWAGED WITH PART TC-30-T AND SPACER	x1	WV20-01-T7
(2) 67MM TUBES SWAGED WITH PART TC-30-X	x1	WV20-01-T2
STEEL PLATE FOR WVC	x2	WVC-PLATE-STD
20' FABRIC GRAPHIC	x1	WV20-01-G

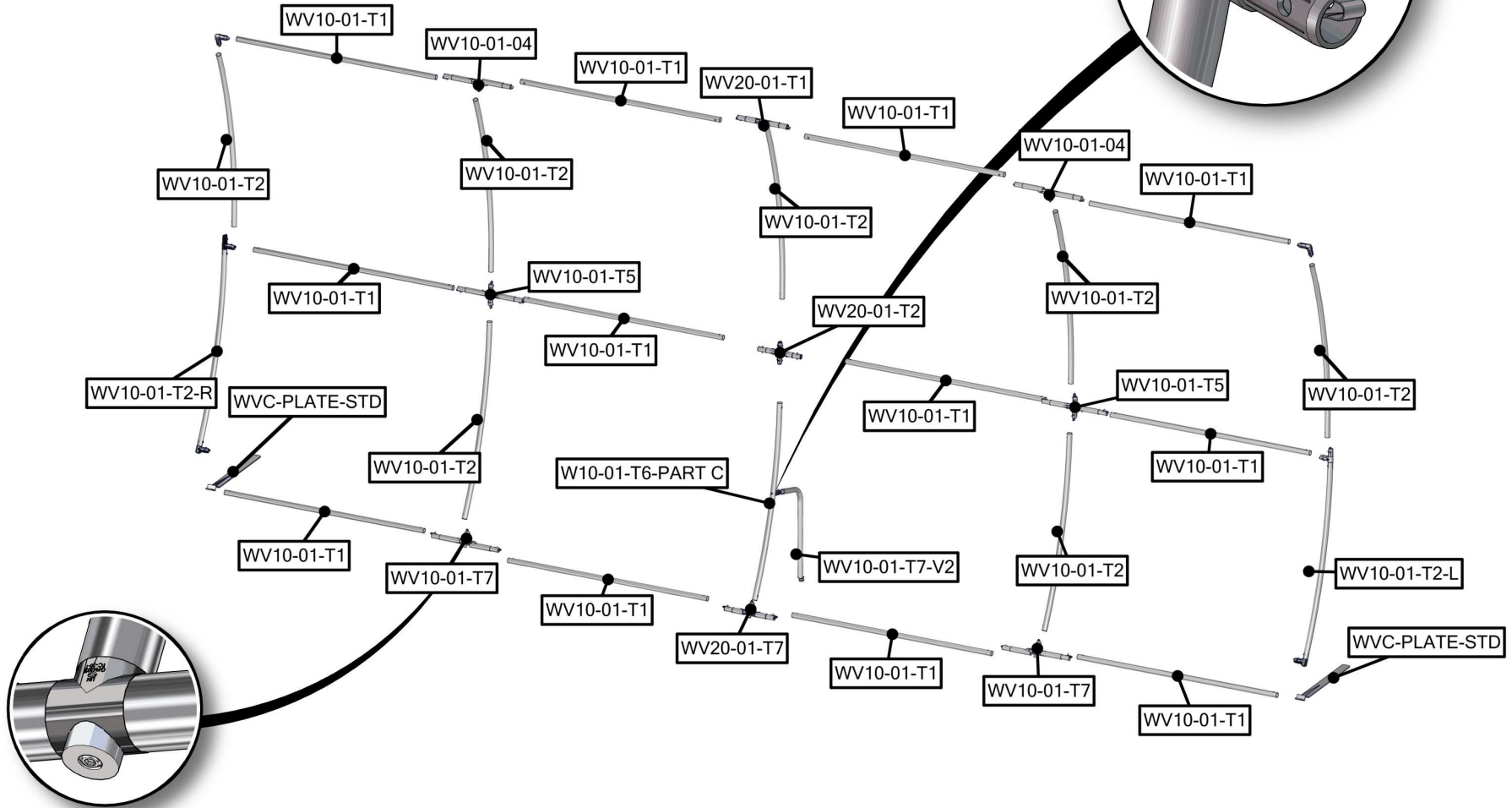
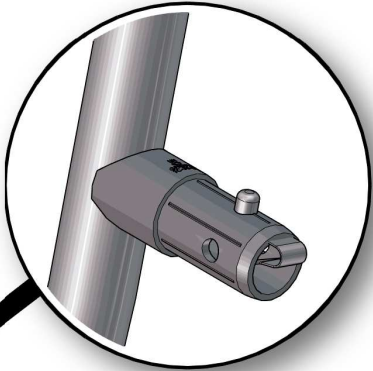

Parts Included		
Part Label	Qty	Part Code
FABRIC GRAPHIC	x1	WV10-01-G
LN114 BOLT	x2	LN114 BOLT
90 DEGREE ELBOW JOINT FOR 30MM TUBING	x2	TC-30-90
1270MM X 30MM TUBE	x6	WV10-01-T1
30MM CURVED TUBE WITH PART T AND 90B LEFT SIDE	x1	WV10-01-T2-L
30MM CURVED TUBE WITH PART T AND 90B RIGHT SIDE	x1	WV10-01-T2-R
R2250 (1163MM ARC) CURVED TUBE	x4	WV10-01-T2
(2) 128MM TUBES SWAGED WITH PART TC-30-T	x2	WV10-01-T7
(2) 128MM TUBES SWAGED WITH PART TC-30-X	x1	WV10-01-T5
STEEL PLATE FOR WVC	x2	WVC-PLATE-STD

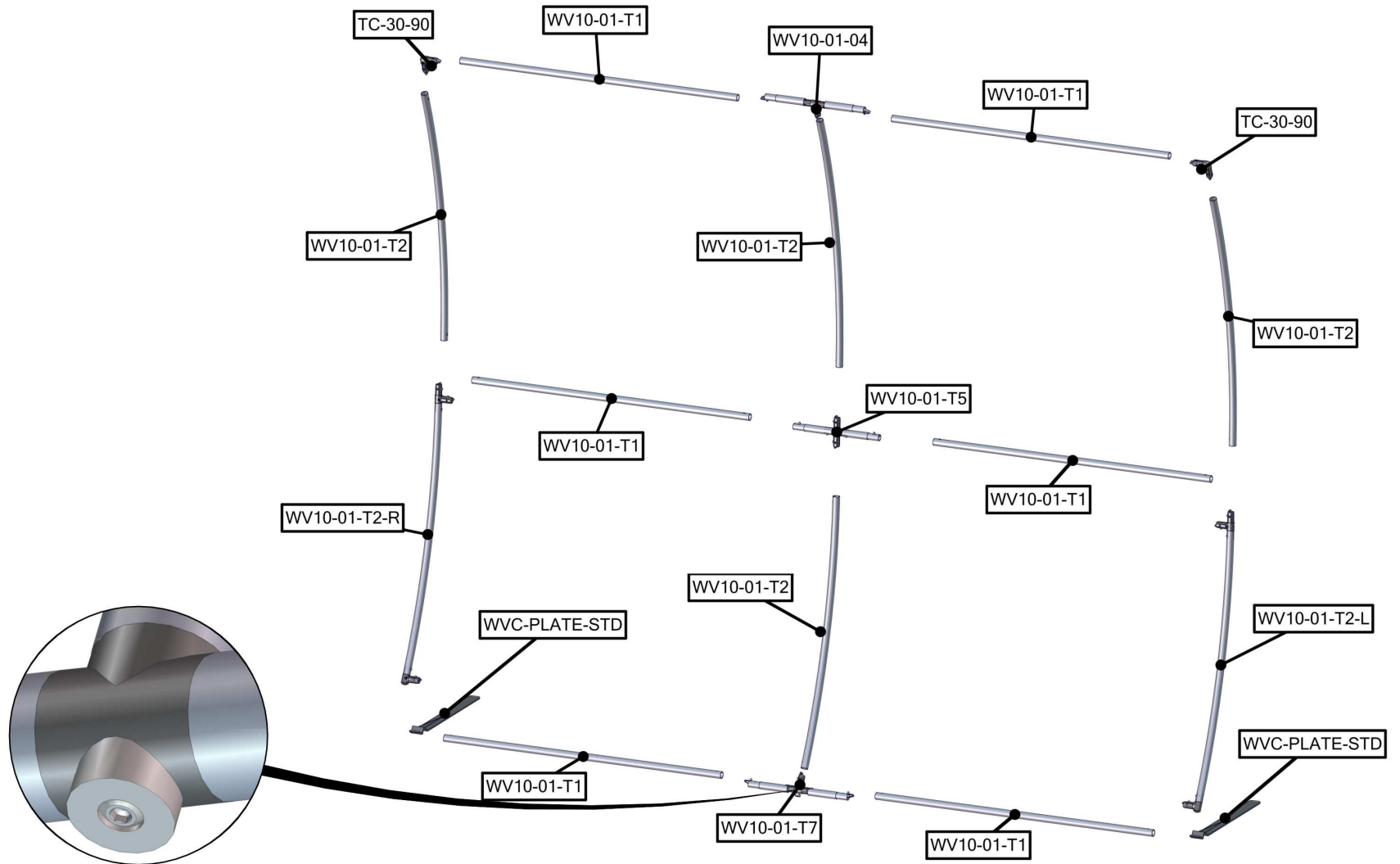

STEP 1: ASSEMBLE FRAME

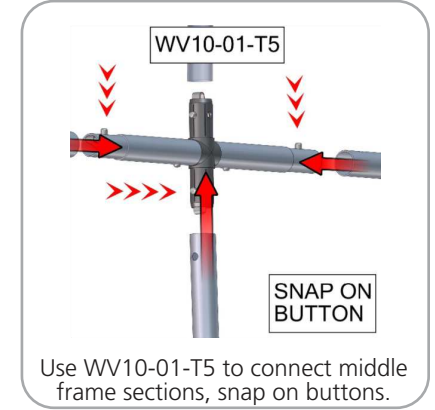
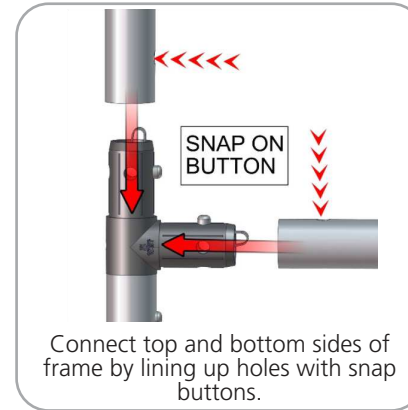
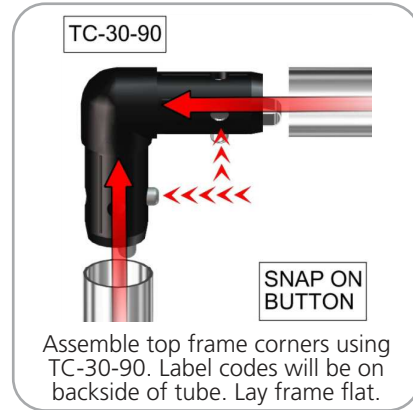
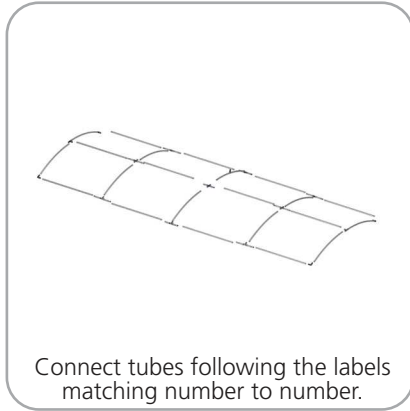

STEP 2: ATTACH FEET



STEP 3: APPLY GRAPHIC

