

# formulate VC6

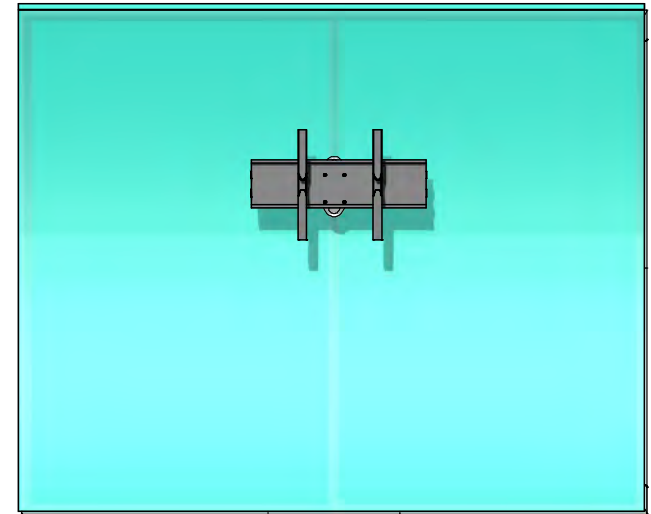
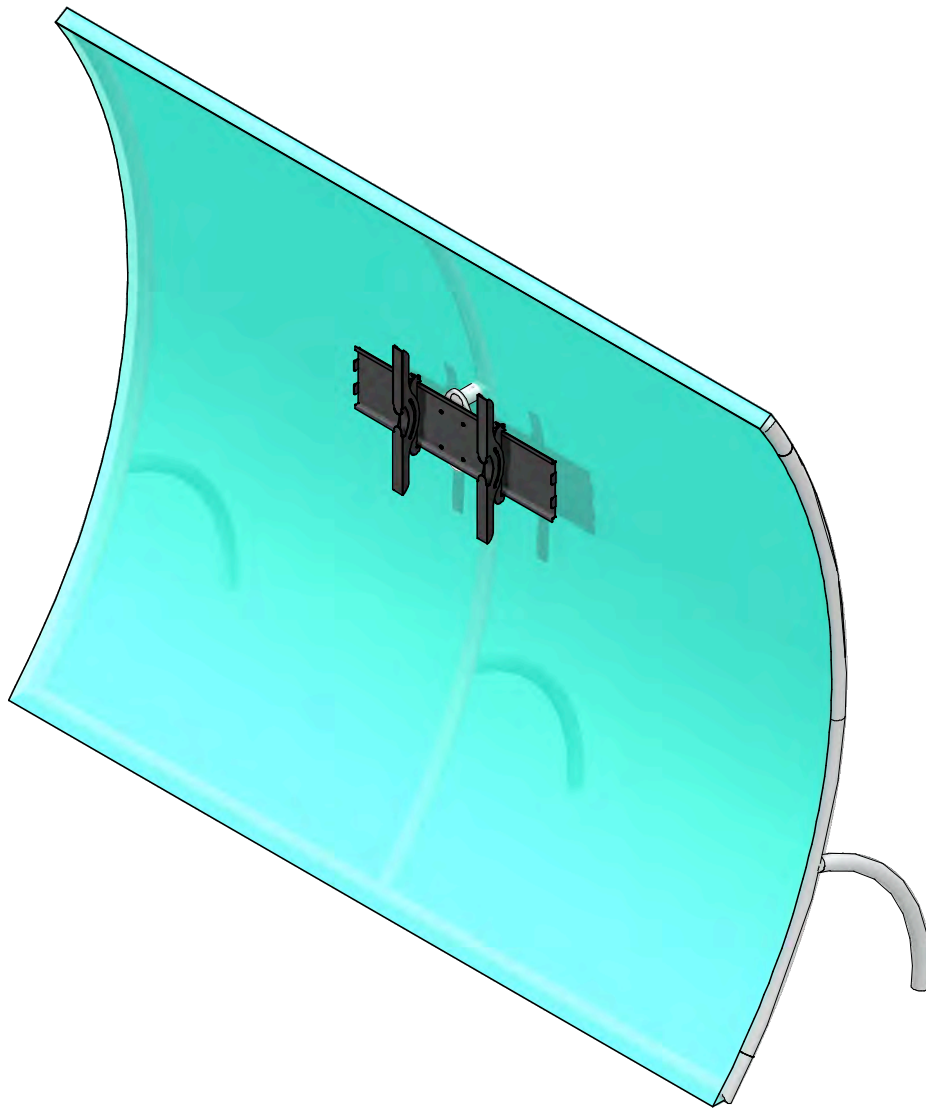

# formulate VC6

## Frame Assembly

Assemble frame as shown

### SET UP INSTRUCTIONS:

1. CONNECT BOTTOM AND TOP RAILS FOLLOWING THE LABELS
2. CONNECT SIDE RAILS
3. CLEAN THE FRAME AND PLACE THEM ON CLEAN PLACE
4. CAREFULLY REMOVE FABRIC COVER FROM BAGS
5. PLACE COVER AROUND THE BOTTOM OF THE FRAME
6. PULL COVER CAREFULLY UP TO THE TOP
7. CLOSE ALL ZIPPERS
8. ADJUST FABRIC AROUND THE FRAME

### BREAK DOWN INSTRUCTIONS:

REVERSE SET-UP STEPS TO BREAKDOWN FRAME

### FABRIC CARE INSTRUCTIONS:

1. UNZIP COVER ZIPPERS
2. CAREFULLY REMOVE FABRIC COVER
3. CLOSE ALL ZIPPERS
4. FOLD OR ROLL NEATLY
5. PLACE FABRIC IN COVER BAG

### PART LIST:

PER UNIT

- 15 50MM DIA. TUBE SECTIONS
- 13 ES-50 EXPANDING SPIGOT
- 1 5MM HEX KEY
- 1 FABRIC COVER

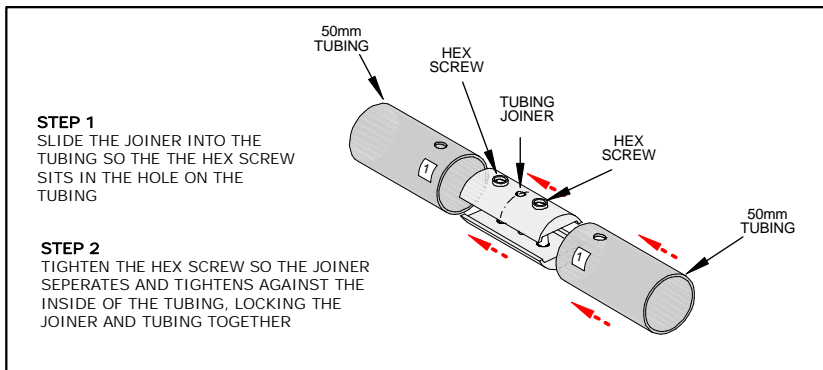
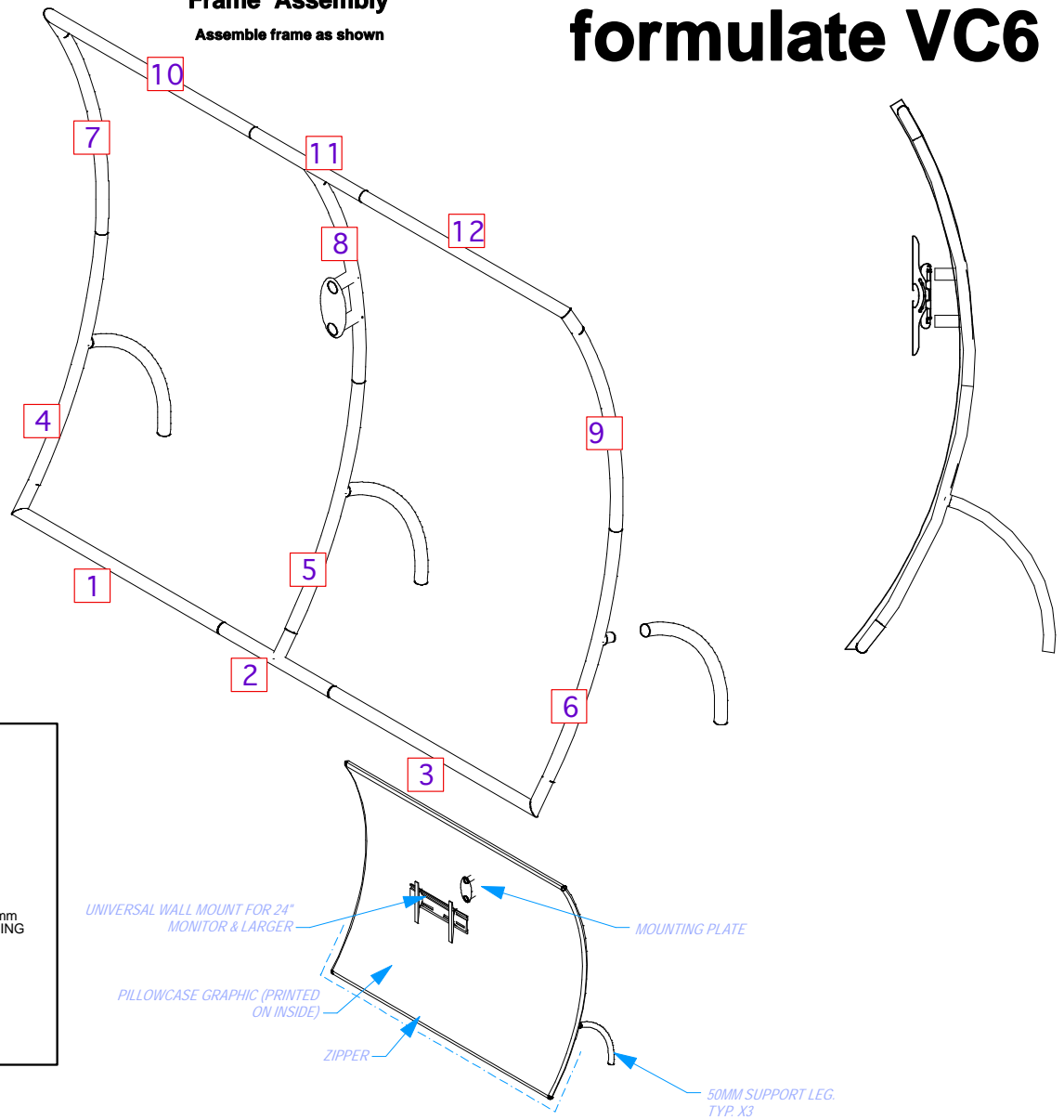

# LARGE MONITOR TO PLATE

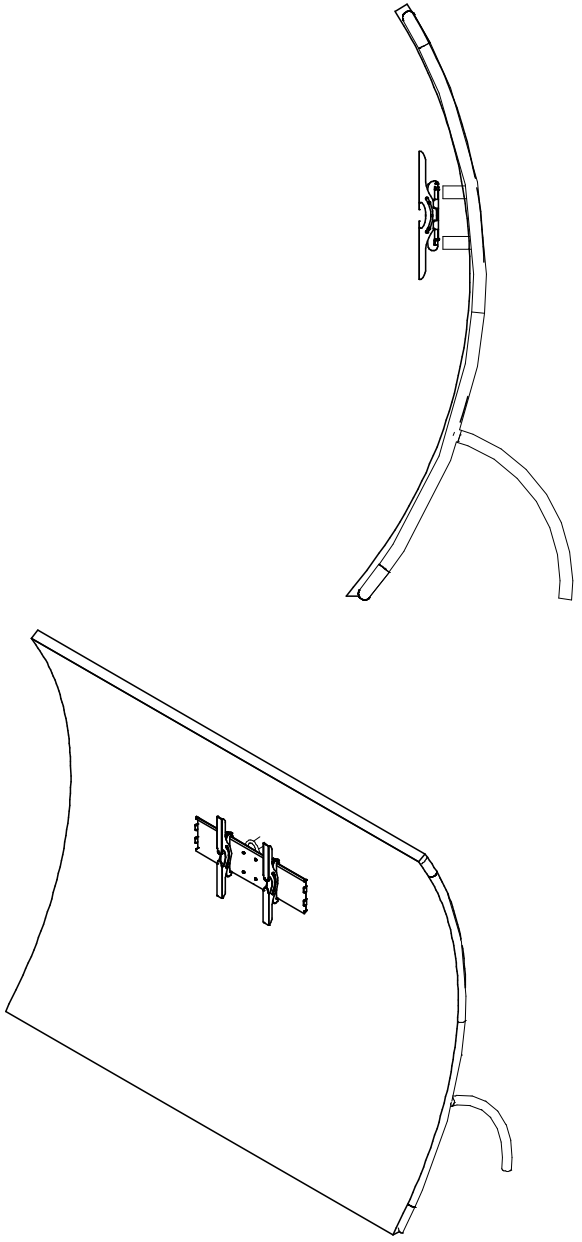
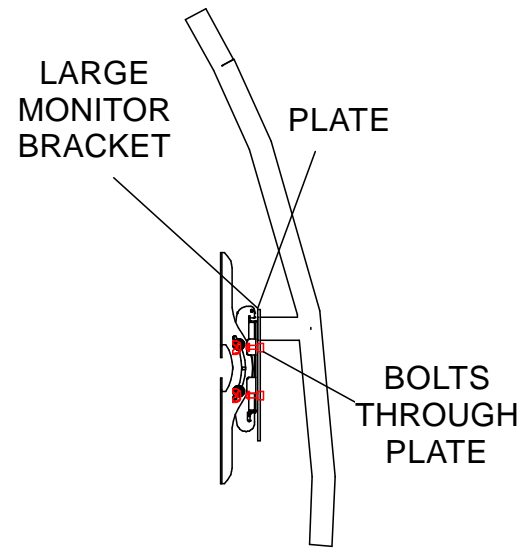
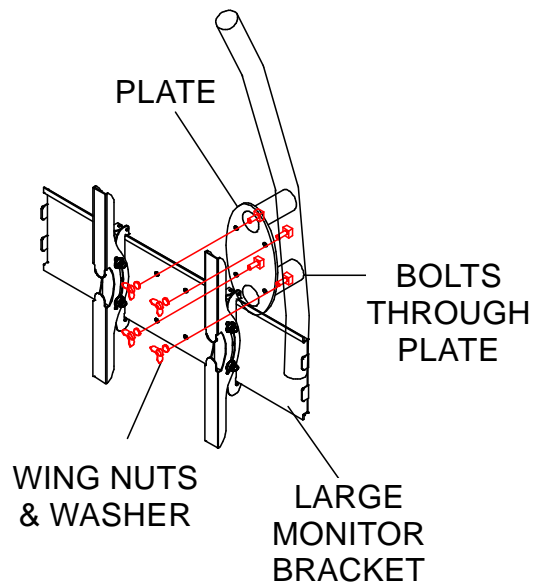

# formulate VC6

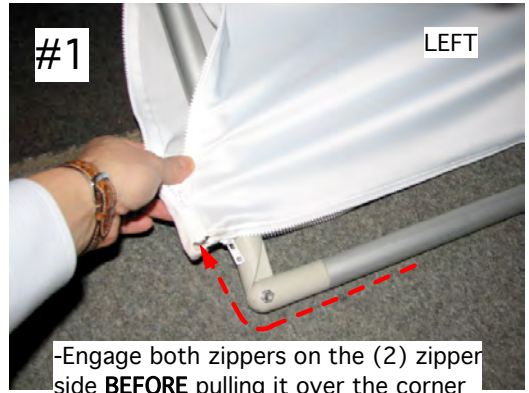

#1 LEFT  
-Engage both zippers on the (2) zipper side **BEFORE** pulling it over the corner of the frame.

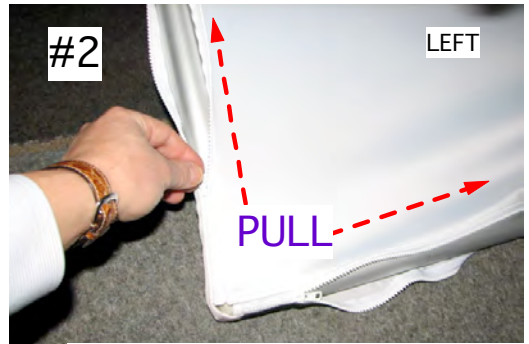

#2 LEFT  
-Pull zippered corner over corner of the frame, **DO NOT ZIP** any more until the end.

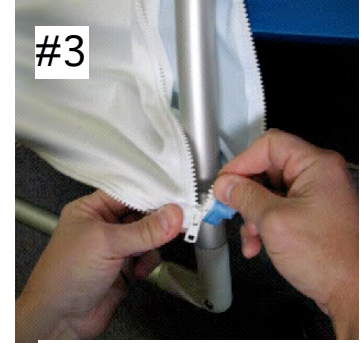

#3 RIGHT  
-Engage zipper on **SINGLE ZIPPER SIDE** BEFORE pulling it over the corner frame

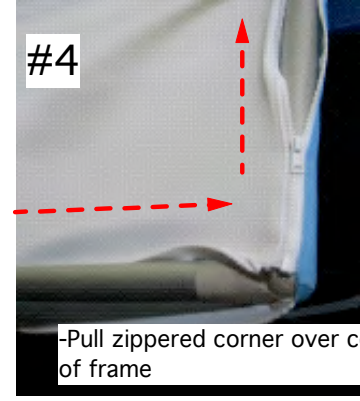

#4 RIGHT  
-Pull zippered corner over corner of frame

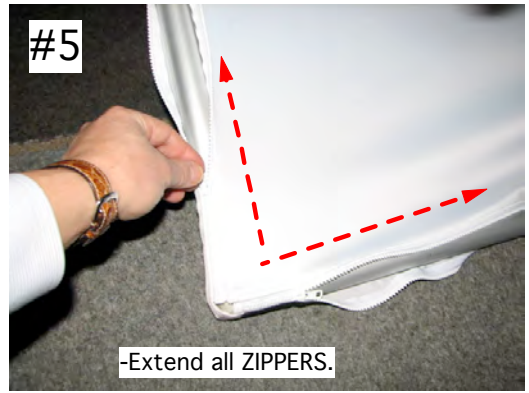

#5  
-Extend all ZIPPERS.

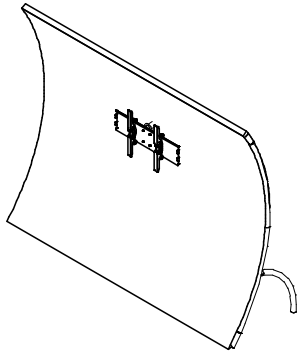

## Fabric Cover Assembly

### Wave Vertical Curve

#### Fabric COVER assembly

- Step 3. Stretch fabric over frame.
- When working with fabric use gloves or clean hands and keep fabric away from dirty surfaces.
- Pull fabric over frame. Start all zippers before pulling over the frame. See detail. Work to keep the zippers evenly aligned along the bottom tube.

- (1) LEFT ZIPPER [VERTICAL]
- (2) BOTTOM ZIPPER [HORIZONTAL]
- (3) RIGHT ZIPPER [VERTICAL]

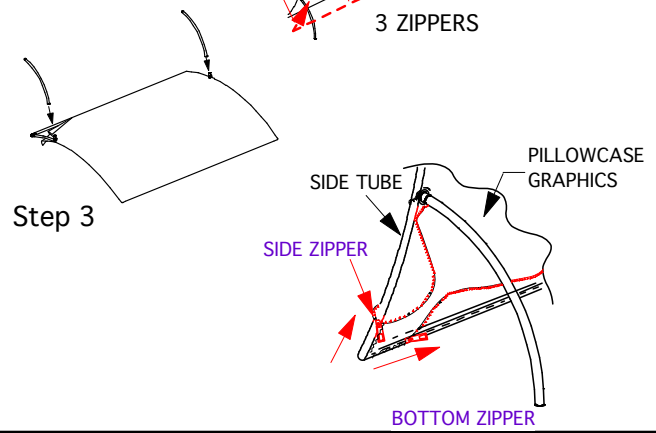

- Add legs to back of unit

Step 4. Stand unit upright.

- Adjust leveling feet on back of legs if needed,

## Packing

All tubes should be put at the bottom



Fabric should be folded and put into smaller zippered bag.



Pack fabric bag last and unpack first.



Hardware box.[All spigots]



**INTERNAL DIMS 48.25"L X 24"W X 14"H**  
**EXTERNAL DIMS 51.5"L X 29"W X 14.5"H**

**OCH2**



**CASE # 1**

## Lighting

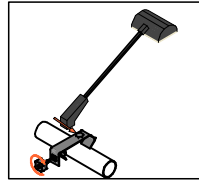

Lights can be attached directly to the top of the frame using a L10 T50 CLIP

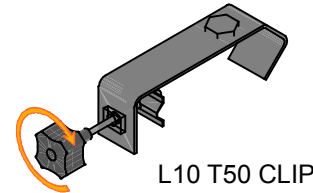

L10 T50 CLIP

## Graphic Header



TC-50

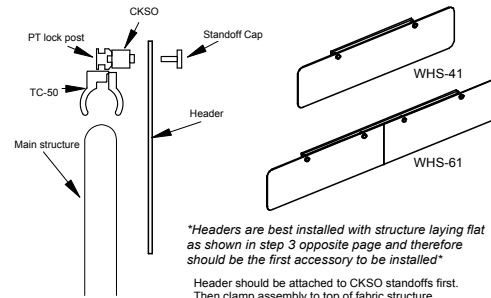

*"Headers are best installed with structure laying flat as shown in step 3 opposite page and therefore should be the first accessory to be installed"*

Header should be attached to CKSO standoffs first. Then clamp assembly to top of fabric structure.

## Shelf Support

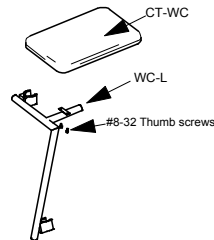

Side counter supports should be attached to side of main frame so that top of support is 39" from ground. Then attach counter top to support with thumb screws.

WC-R, not shown, attaches to right side of frame.

## Literature Holder

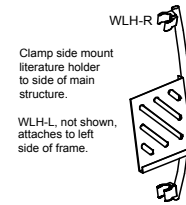

Clamp side mount literature holder to side of main structure.

WLH-L, not shown, attaches to left side of frame.

# formulate VC6

## Accessories

Accessories should be installed after fabric structure is assembled and fabric is put on frame. If using header, install header first.