

Vector Frame Kit 09

VF-K-09

The innovative, contemporary and clean appearance of the Vector Frame™ line of exhibit kits will captivate your audience. Kits feature push-fit fabric graphics, easy-to-assemble extrusion frames, accent lighting, tables, counters, literature accessories, monitor mounts and interior LED edge lighting where indicated.

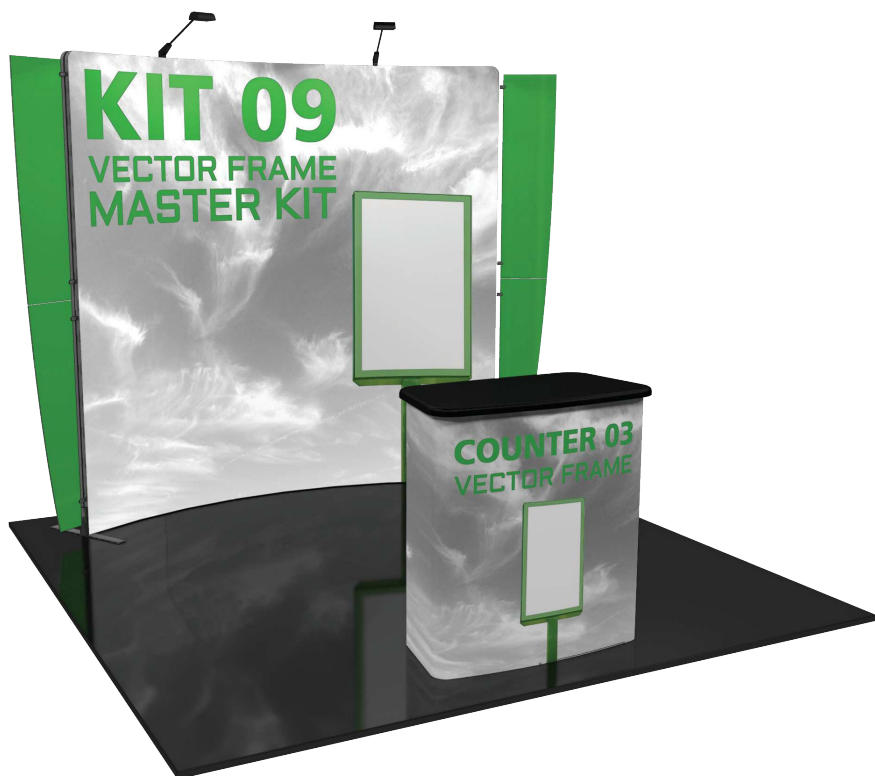

features and benefits:

- 50mm silver extrusion frame
- Single-sided SEG dye-sublimated fabric graphics
- Counter available in four thermoform finishes, shown below
- Kit includes frame, five fabric graphics, two 120 watt lights, counter and two wheeled molded cases
- Lifetime hardware warranty against manufacturer defects

dimensions:

Hardware	Graphic
<p>Assembled Unit: 117" w x 102" h x 23" d 2972mm(w) x 2591mm(h) x 584mm(d)</p> <p>Counter: 38.5" w x 40.5" h x 19.875" d 978mm(w) x 1029mm(h) x 505mm(d)</p>	<p>Total visual area: Center graphic panel: 99.3" w x 94.5" h 2522mm(w) x 2400mm(h)</p> <p>Top accent wings: 11.811" w x 45.27" h 300mm(w) x 1150mm(h)</p> <p>Bottom accent wings: 10.62" w x 45.27" h 270mm(w) x 1150mm(h)</p>
<p>Shipping Dimensions - ships in 2 cases: 1 OCH2 case: 52" l x 30" w x 15" h 1320mm(l) x 760mm(w) x 380mm(h)</p> <p>1 OCE case: 66" l x 18" w x 18" h 1676mm(l) x 457mm(w) x 457mm(h)</p> <p>Approximate shipping weight (entire kit): 162.54 lbs / 73.7 kgs</p>	<p>Counter: Front (wraps around counter): 82.17" w x 39.38" h 2087mm(w) x 1000.25mm(h)</p> <p>Back door graphic: 14.92" w x 39.38" h 379mm(w) x 1000.25mm(h)</p> <p>Please be sure to include a 2" bleed around the perimeter.</p> <p>Refer to related graphic templates for more information</p>

additional information:

Graphic material:
Dye-sublimated fabric

Tabletop color options:



silver



black



mahogany



natural

Lights Included:
Lumina 200 120 watt floodlight, curved arm, black finish, 19.5" from end to end

Counter holds max weight
100 lbs / 45.4 kgs

We are continually improving and modifying our product range and reserve the right to vary the specifications without prior notice. All dimensions and weights quoted are approximate and we accept no responsibility for variance. E&OE. See Graphic Templates for graphic bleed specifications.

Parts Included:

Code	Qty	Description
VF-K-9-A-G	x1	300MM (11.81")W X 1150MM (45.27")H PVC GRAPHIC
VF-K-9-B-G	x1	300MM (11.81")W X 1150MM (45.27")H PVC GRAPHIC
VF-K-9-C-G	x1	2522MM (99.3") X 2400MM (94.5")H FABRIC GRAPHIC W/FCE-2 ALL SIDES
VF-K-9-D-G	x1	300MM (11.81")W X 1150MM (45.27")H PVC GRAPHIC
VF-K-9-E-G	x1	300MM (11.81")W X 1150MM (45.27")H PVC GRAPHIC
F52	x4	8R PHFC2 EXTRUSION WITH LOCK ONE SIDE - WITH IB2 LOCK HOLES ONE SIDE
F34	x4	1155MM (45.47") PHFC2 EXTRUSION - WITH IB2 HOLE ONE SIDE - WITH LOCK ONE END
SW-FOOT	x2	VECTOR FRAME SUPPORT FOOT
IB2	x5	PH INLINE CONNECTOR
CB9-R	x2	50MM ROUND PHCF2 CORNER BRACKET
CB9-S	x2	50MM SQUARE PHCF2 CORNER BRACKET
LUM-200-ORL-B LN-3P-LT-FXT	x2	BLACK 200W HALOGEN LIGHT FIXTURE ETL APPROVED
VE-70	x2	1155MM (45.47") PH EXTRUSION WITH IB2 HOLE ONE SIDE - WITH LOCK ONE END
PANEL CLAMP	x8	7MM PLASTIC MOLDED PANEL CLAMP

VF-K-09

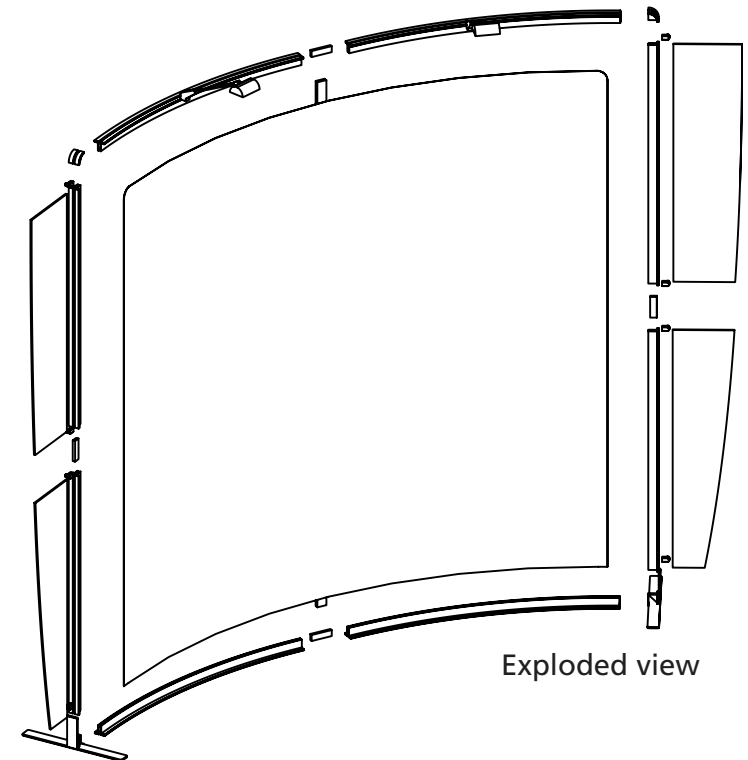
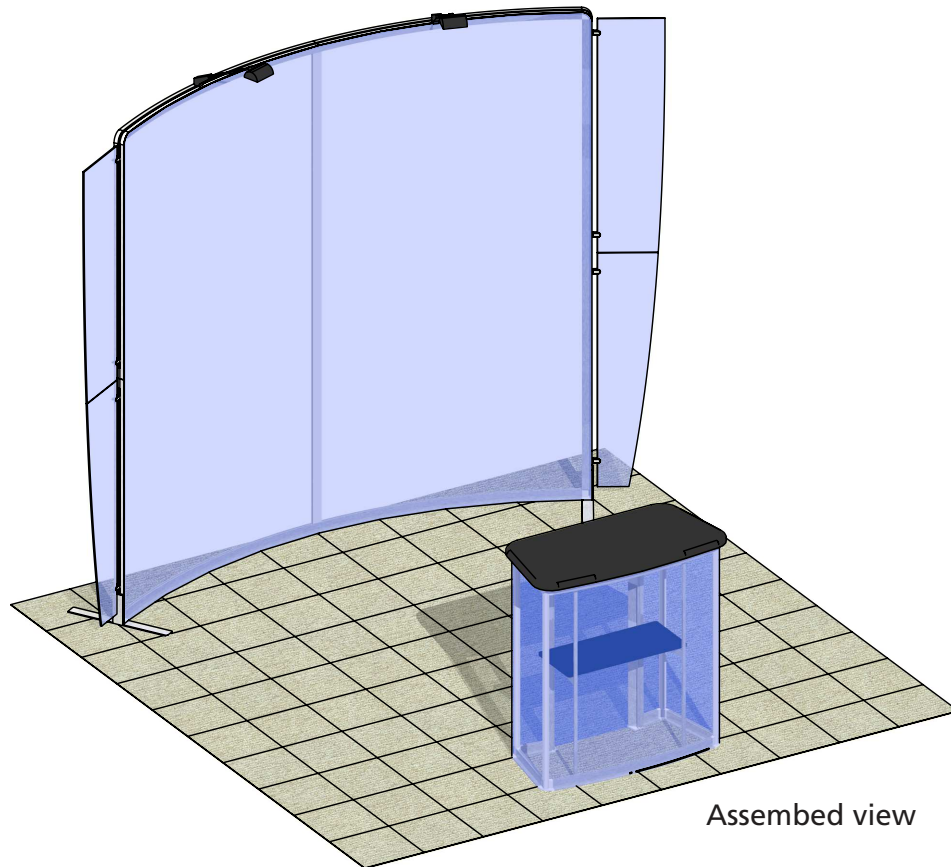
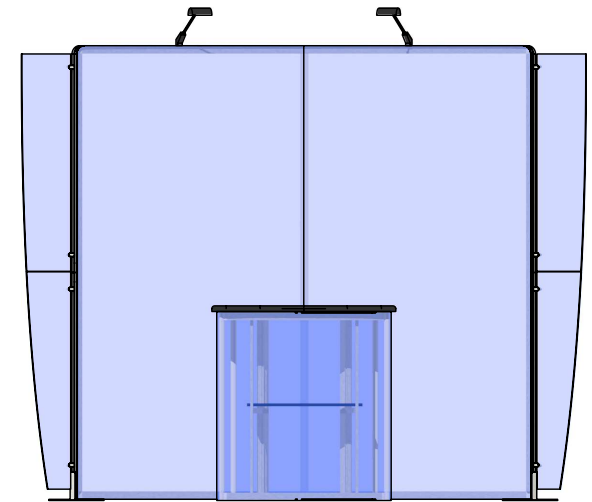

Step 1: Assemble Center Frame

Arrange pieces on the floor as shown in the diagram below. Assemble frame by securing CB9-R's on the top and CB9-S's on the bottom to the F52 and F34s. When locking be sure to turn each cam a little bit and then go back and tighten to the proper tension. Take care to turn locks only half a turn. Slide the IB2 into the extrusion to connect sides. Tighten to the proper tension to lock extrusions together. To adhere foot to frame, loosen thumbscrews from foot. Slide extrusion into LN-100 groove. Tighten to the proper tension to secure supporting feet.

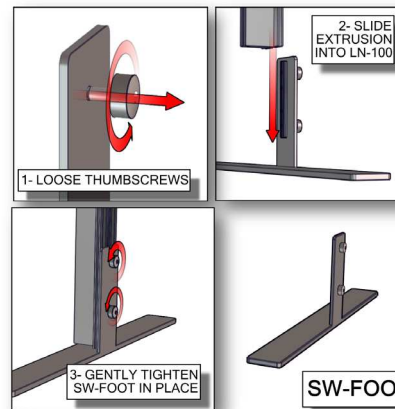
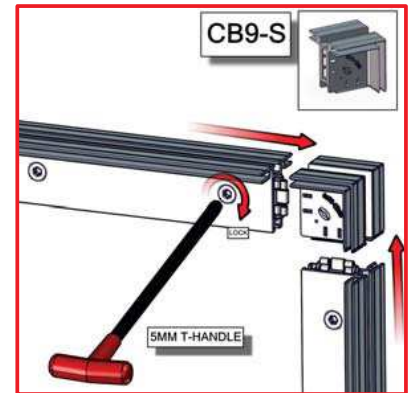
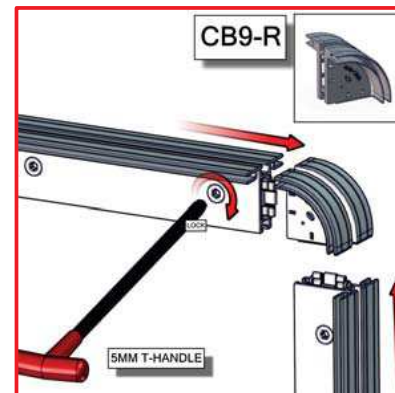
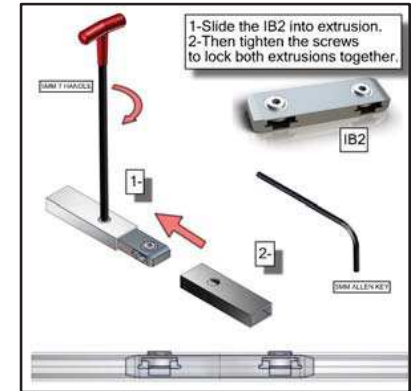
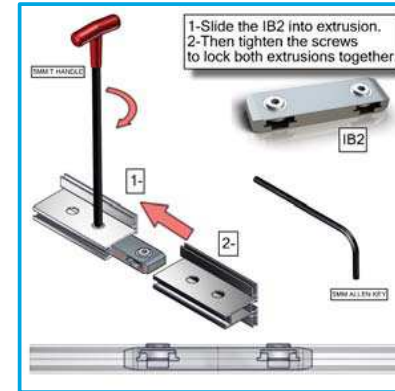
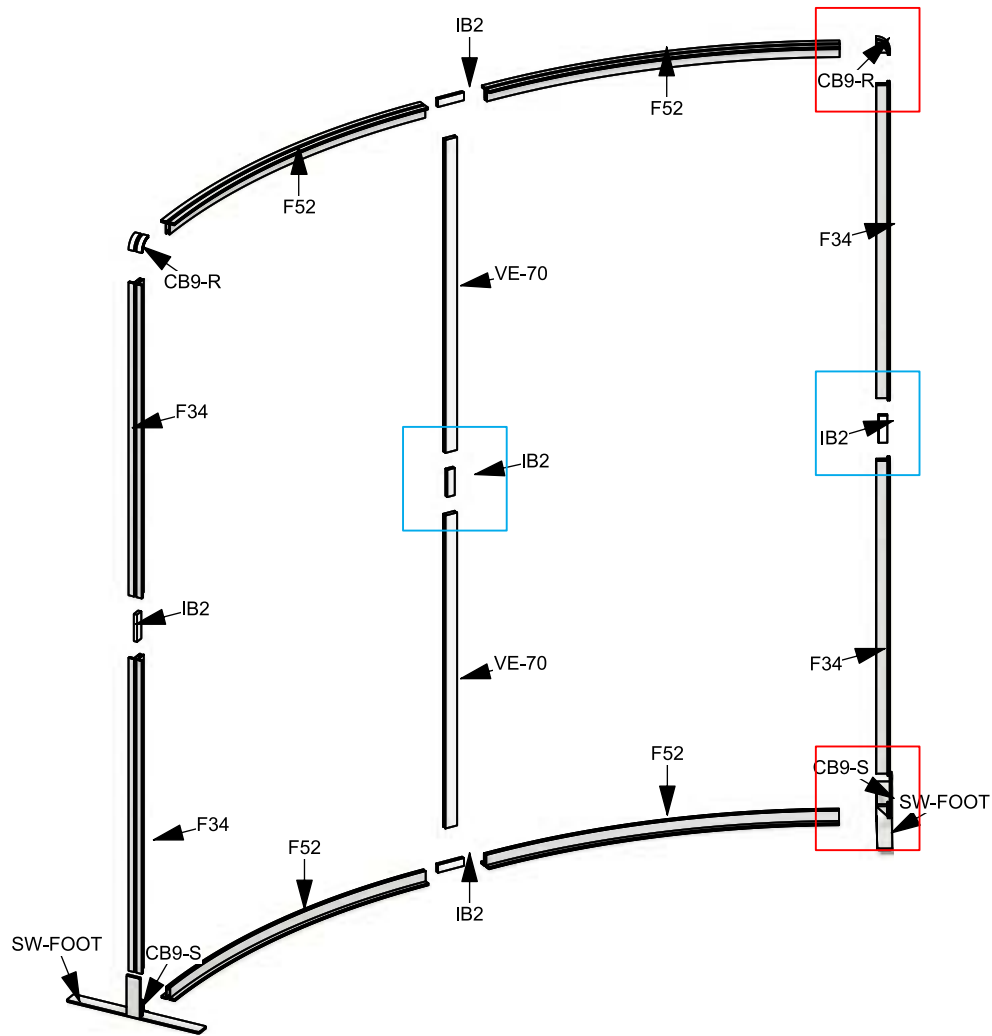

Step 2: Apply Center Panel Graphics

Install graphic(s) by pressing the FCE-2 edge of graphic into the channel of the extrusion. Start in upper left corner and insert in remaining corners, then push graphic into each side. Assure graphic is tightly inserted. When taking graphics off, take care to gently pull by attached pull tab.

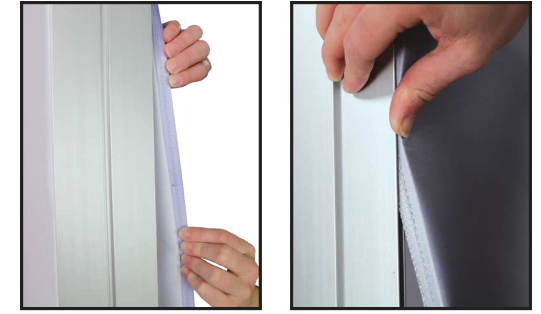
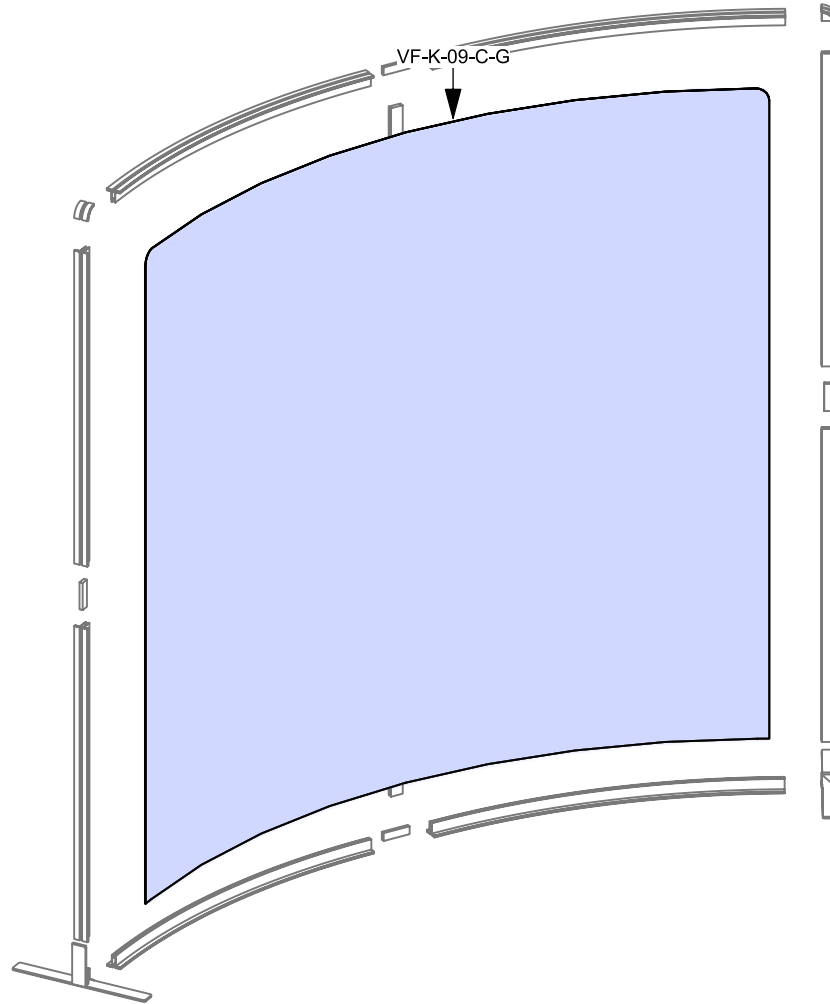

FCE-2 TO PHFC2

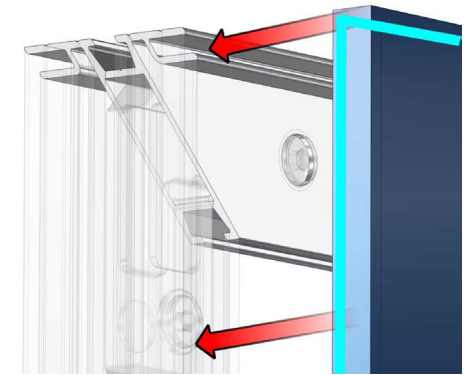

FCE-2 TO PHFC2

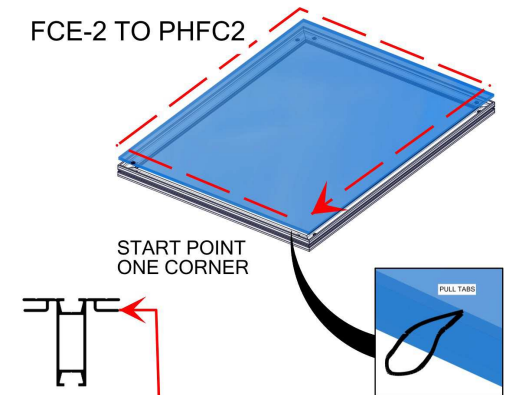

Install graphic by pressing the FCE-2 into the channels of PHFC2 extrusion. To pull graphics out of the channels, use tabs on the front side

Step 3: Attach Accent Wings & Lights

To attach accent wings, screw panel clamp clockwise, into the channel until it is tight. Loosen the thumbscrew. Place rigid sintra graphics into place and tighten thumbscrew to secure. Slide light clip onto each light. Then slide light into the extrusion channel at an angle and gently lower down and repeat for each light.

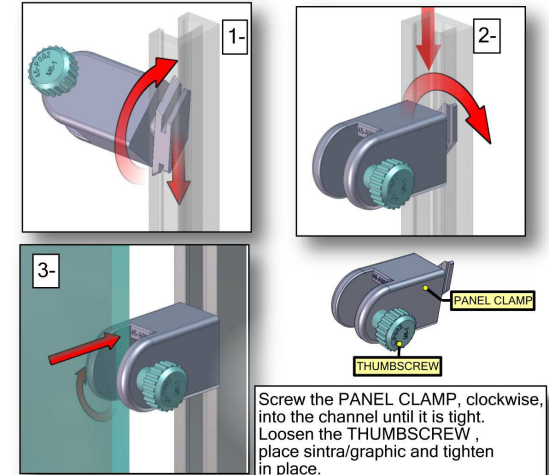
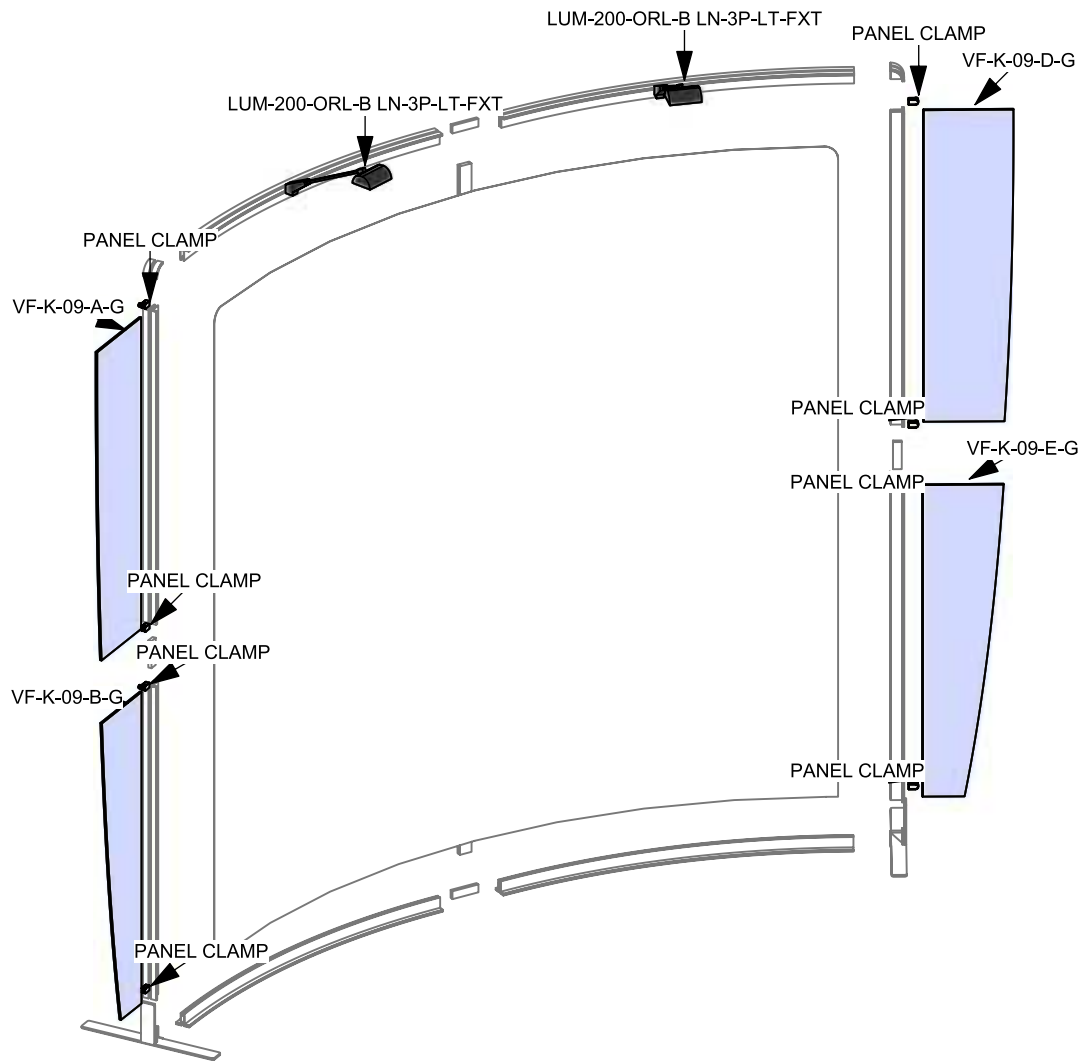

Over-tightening can cause to strip

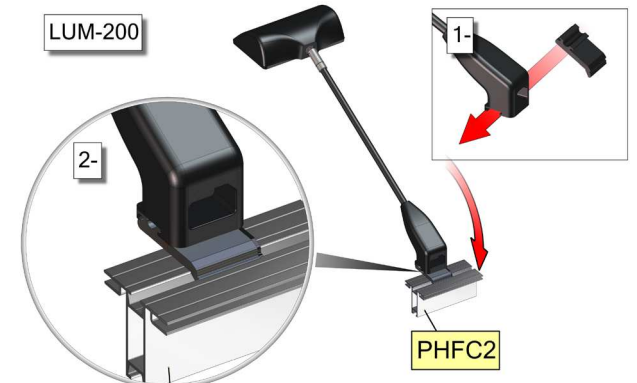

1- Slide light clip onto the LIGHT.
2- Then slide the LIGHT into the channel at an angle and then gently lower down.

Parts Included:

Code	Qty	Description
F54	x2	8R X 20 DEGREE PHFC2 EXTRUSION - WITH CAM LOCKS BOTH ENDS
F43	x4	300MM (11.81") PHFC2 EXTRUSION WITH LOCKS TWO ENDS
F48	x4	100MM (3.94") PHFC2 EXTRUSION WITH LOCKS TWO ENDS
F24	x2	986MM (38.32") PMFC2-90 EXTRUSION - WITH IB2 LOCK HOLES BOTH SIDES
CB10-R	x8	50MM ROUND PHCF2 CORNER BRACKET
VFC-03-CT	x1	COUNTERTOP FOR VECTOR COUNTER VFC-03
VFC-03-CT-S	x1	INTERNAL SHELF FOR VECTOR COUNTER VFC-03
VFC-03-B-G	x1	362MM (14.92")W X 1000MM (39.38")H FABRIC GRAPHIC W/FCE-2 ALL SIDES
VFC-03-A-G	x1	2087MM (82.17")W X 1000MM (39.38")H FABRIC GRAPHIC W/FCE-2 ALL SIDES
TUBE-30-910	x4	910MM (35.82") X 30MM TUBE WITH ES30 HOLES BOTH ENDS
PMFC2-90 CAP	x4	PMFC2 90 DEGREE EXTRUSION CAP
VE-80	x4	288MM (11.34") PH1 EXTRUSION WITH LOCKS BOTH SIDES
PE-1000	x2	1000MM (39.38") PE EXTRUSION

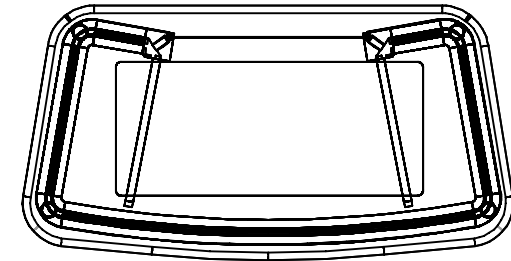

Overhead view

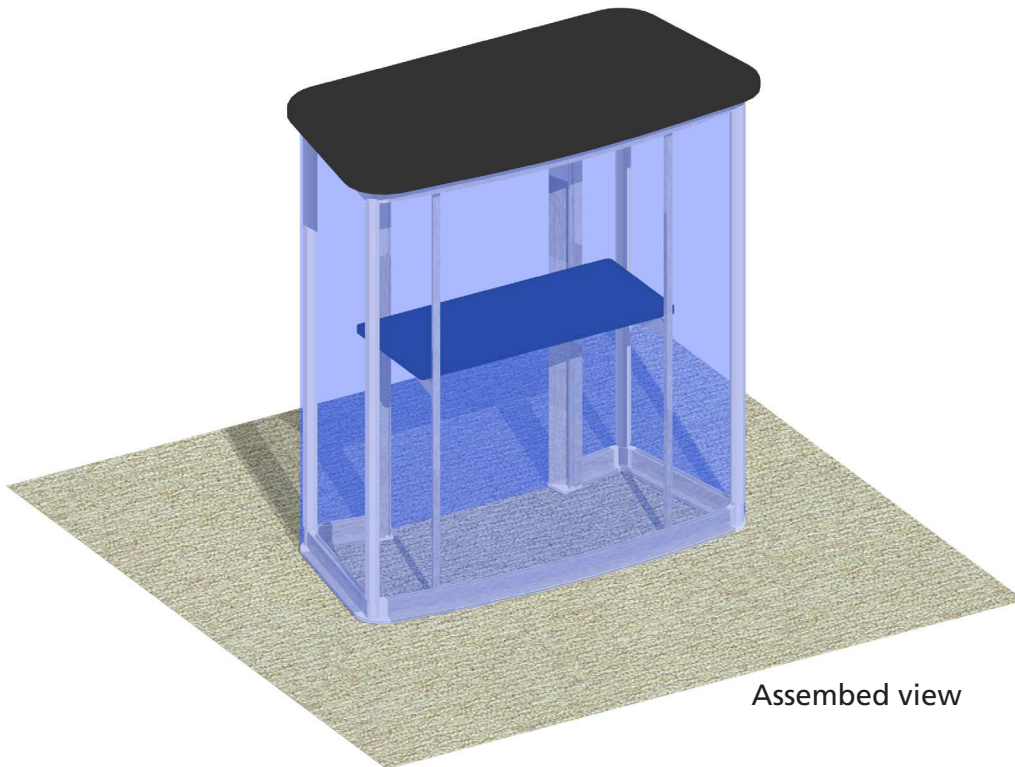

Assembled view

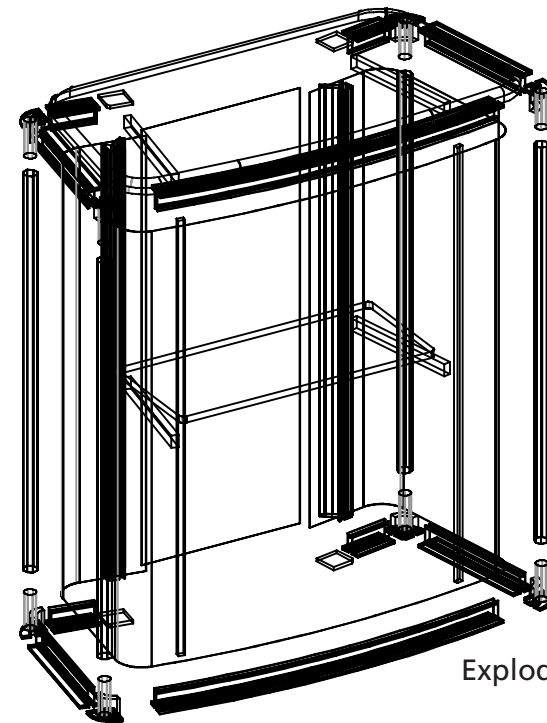

Exploded view

Step 1: Assemble Counter Frame

Arrange pieces on the floor as shown in the diagram below. Assemble frame sides by securing CB10-R to F43 and TUBE-30-910. Continue frame assembly by locking F48s, F54s and F24s to extrusion. When locking be sure to turn each cam a little bit and then go back and tighten to the proper tension. Take care to turn locks only a quarter turn, so as to not strip the locks by over tightening.

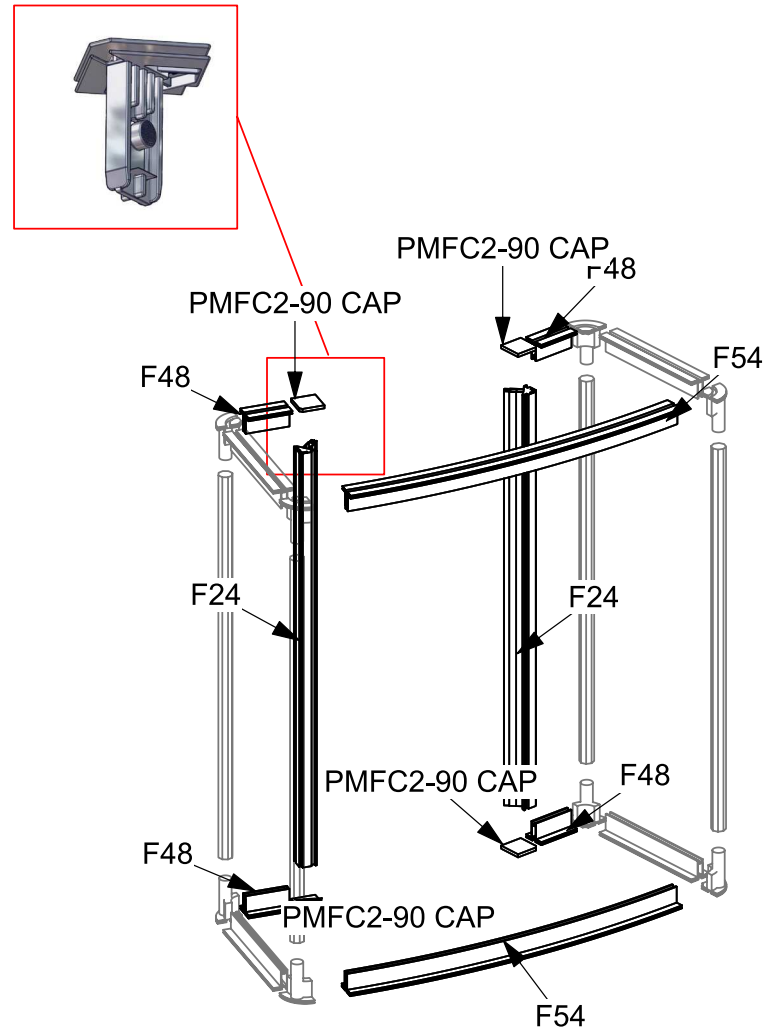
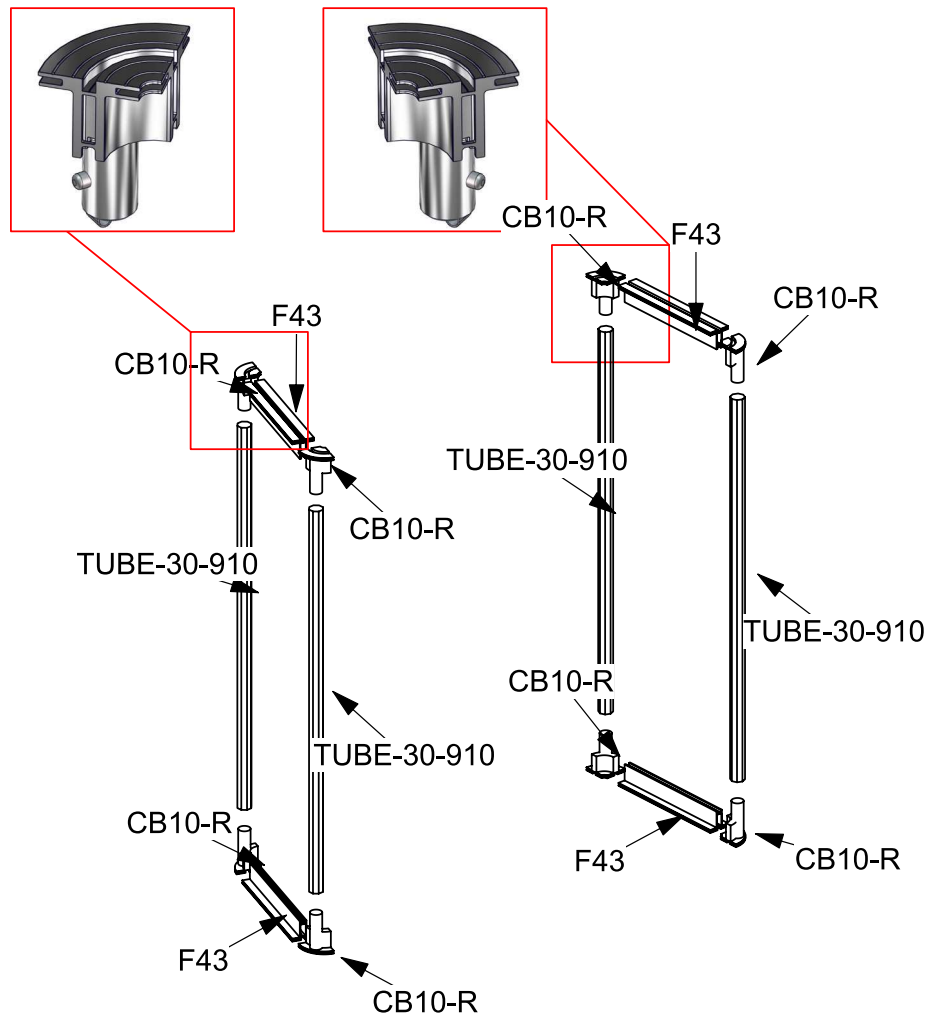
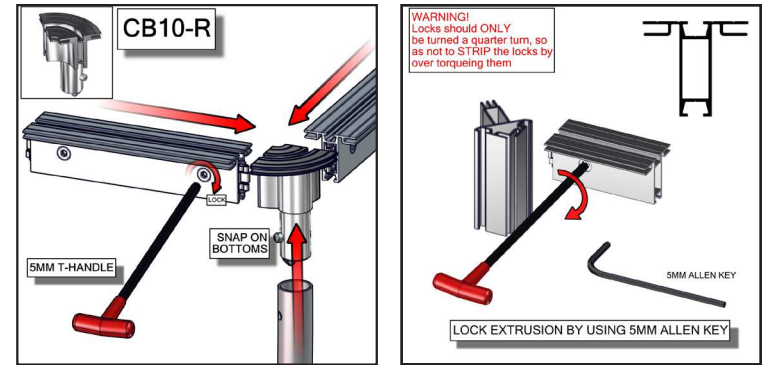

Step 2: Install Internal Shelf, Apply Graphics & Attach Countertop

To install internal shelf, secure VE-80 and PE-1000 and install VFC-03-CT-S. Then, apply push-fit fabric graphic(s) by pressing the FCE-2 edge of graphic into the channel of the extrusion. Start in upper left corner, go across the top and then down the sides to the bottom. Repeat for each side. Assure each graphic is tightly inserted. When taking graphics off, take care to gently pull by attached pull tab. Next, gently place the countertop onto the completed frame.

