

Hybrid Pro Modular Kit 14

HP-K-14

Hybrid Pro™ Modular exhibits and counters are a perfect solution for the serious exhibitor. Exhibits feature heavy-duty aluminum extrusion frames and push-fit fabric graphics. Count on making an unforgettable impact with Hybrid Pro Modular exhibit kits, counters, and accessories.



* foreground counter not included

We are continually improving and modifying our product range and reserve the right to vary the specifications without prior notice. All dimensions and weights quoted are approximate and we accept no responsibility for variance. E&OE. See Graphic Templates for graphic bleed specifications.

features and benefits:

- Silver aluminum extrusion frame
- Single-sided SEG dye-sublimated push-fit fabric graphic
- Easy step-by-step instructions
- Kit includes frame, two fabric graphic panels, three counters, three medium monitor mounts, four 200 LED floodlights, one OCH2 molded case and one SCRATCH case
- Lifetime hardware warranty against manufacturer defects

dimensions:

Hardware

Assembled unit:
225.13" w x 94.75" h x 41.69" d
5718.3mm(w) x 2406.7mm(h) x 1058.93mm(d)

Counters:
25.5" w x 39.2" h x 15.1" d approx.
647.7mm(w) x 995.68mm(h) x 383.54mm(d)

Counter holds max weight 50 lbs / 22.68 kgs

Shipping

Shipping dimensions - ships in 2 cases:
1 OCH2 case: 52" l x 30" h x 15" d
1320.8mm(l) x 762mm(h) x 381mm(d)

1 SCRATCH case: 59" l x 57" h x 34" d
1498.6mm(l) x 1447.8mm(h) x 863.6mm(d)

Approximate shipping weight (entire kit):
464 lbs / 210.5 kgs

Graphic

Total visual area:
Panels A, B: 118" w x 94.375" h
2997mm(w) x 2397mm(h)

Counter sides: 11" w x 35.81" h
279.4(w) x 909.57mm(h)

Counter Door: 17.53" w x 32.18" h
445.26mm(w) x 817.372mm(h)

Please be sure to include a 2" bleed around the perimeter.

Refer to related graphic templates for more information



ZZZ FDPHOEDFNGLVSD\

additional information:

Fabric material: Dye-sublimated fabric and UV printed on 6mm white Sintra

Tabletop color options:

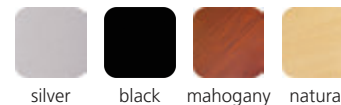

silver black mahogany natural

Lights Included: Lumina 200 LED floodlight, straight arm and adjustable head, black finish, 19.5" from end to end

Each medium monitor bracket holds 24-40" LCD, maximum weight: 50 lbs / 22.68 kgs

*Foreground counter and monitors not included

R-HP-K-14

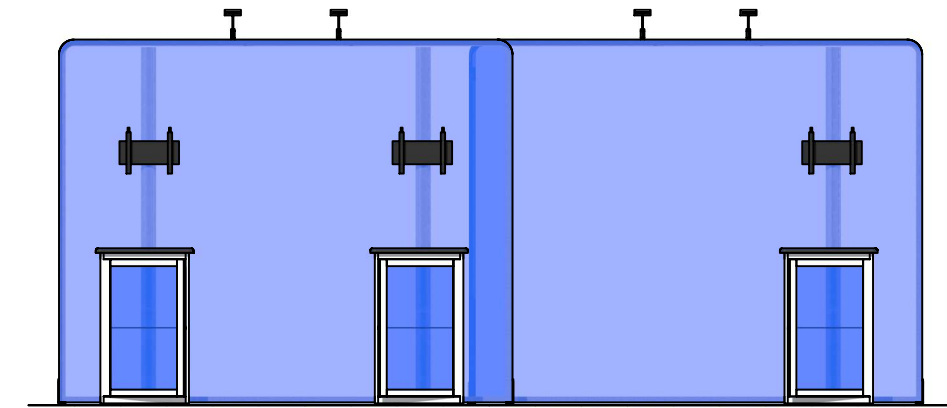
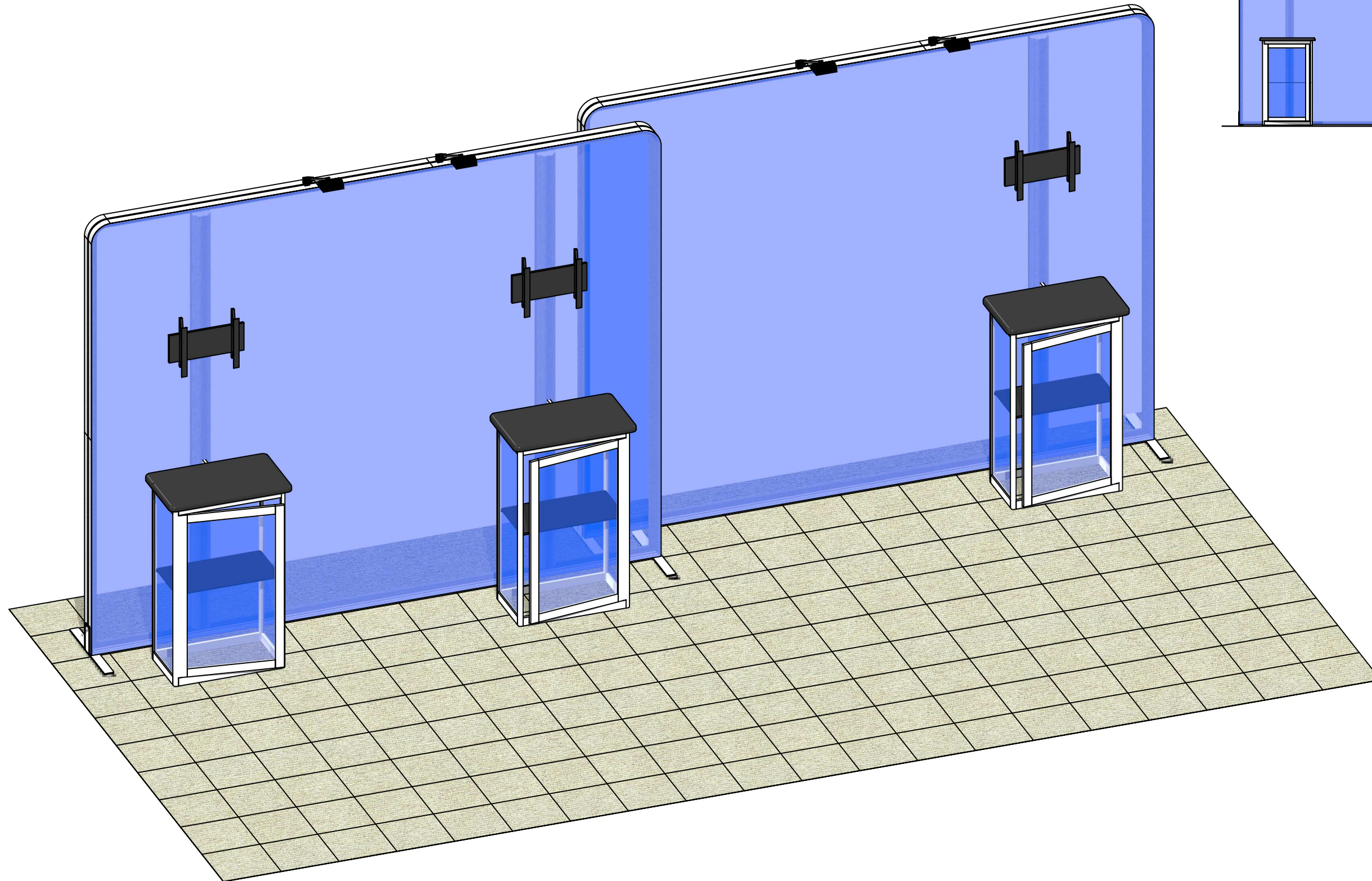

Code	#	Description
INTERNAL SHELF	3	292MM X 553 (11 1/2" X 21 3/4") INTERNAL SHELF FOR V-CU-CAB-01
R50	12	280MM (11") PH WITH SLIDE LOCK AT BOTH ENDS
R54	6	922MM X 292MM (36 5/16" X 11 1/2") SIDE SINTRA/FOAMEX
R53	3	581MM X 1000MM (22 7/8" X 39 3/8") FRONT FRAME W/GFX INFILL
R52	3	581MM X 1000MM (22 7/8" X 39 3/8") CABINET DOOR W/GFX INFILL
V-SS1	12	SHELF SUPPORT
V-CW-CT-01	3	384MM X 646MM (15 1/8" X 25 7/16") HYBRID RECTANGLE TOP
SW-FOOT	4	SMARTWALL SUPPORT FOOT
R27	8	1200MM (47.24") PHFC4 EXTRUSION WITH MITRE CUT 1 END FOR CB9 ONE END-IB2 HOLES ONE END
R45	8	1100MM (43.31") PHFC4 EXTRUSION WITH IB2 LOCK HOLES ONE SIDE-LOCK ONE SIDE
CB9	4	CB9 CORNER BRACKET
IB2	12	INLINE BRACKET CONNECTOR
CB100-R	4	100MM ROUND PHFC4 CORNER BRACKET
R46	4	600MM (23.62") PHFC4 EXTRUSION WITH IB2 HOLES BOTH ENDS
GRAPHIC A	1	94.5"H X 118.11"W SINGLE SIDED DYESUB GRAPHIC W/FCE-2 ON PERIMETER
R22	6	1155MM (45.47") 100MM PM4R8 ROUND EXTRUSION WITH LOCKS 1 END WITH PH2 STOP AT 305MM
R14	3	300MM (11.81") PM4D CONNECTOR WITH TENSION GLIDES
GRAPHIC B	1	94.5"H X 118.11"W SINGLE SIDED DYESUB GRAPHIC W/FCE-2 ON PERIMETER
L10T LIGHT	4	200W HALOGEN LIGHT FIXTURE (ETL APPROVED) **WITH NIMTRUSS CLIP
R48	3	100MM (3.94") PH1 EXTRUSION WITH LOCKS 2 ENDS

BOM

R-HP-K-14

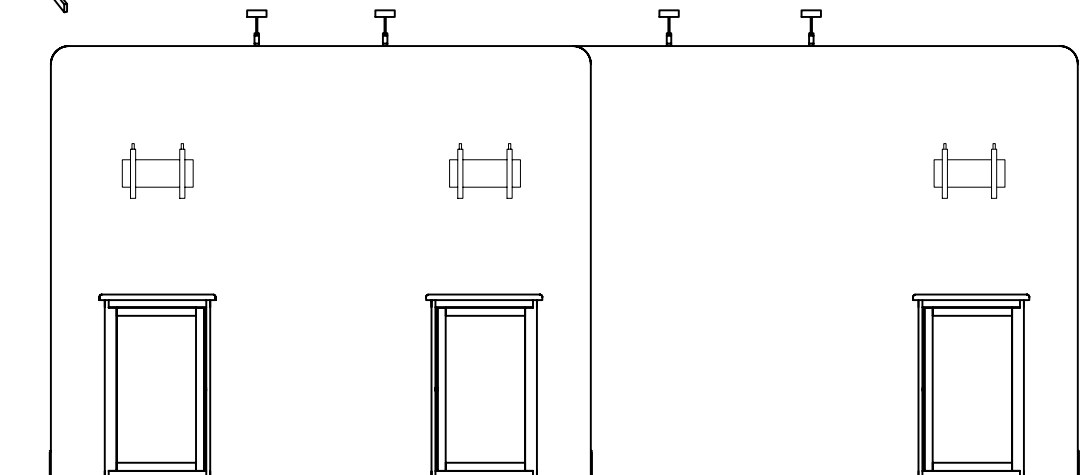
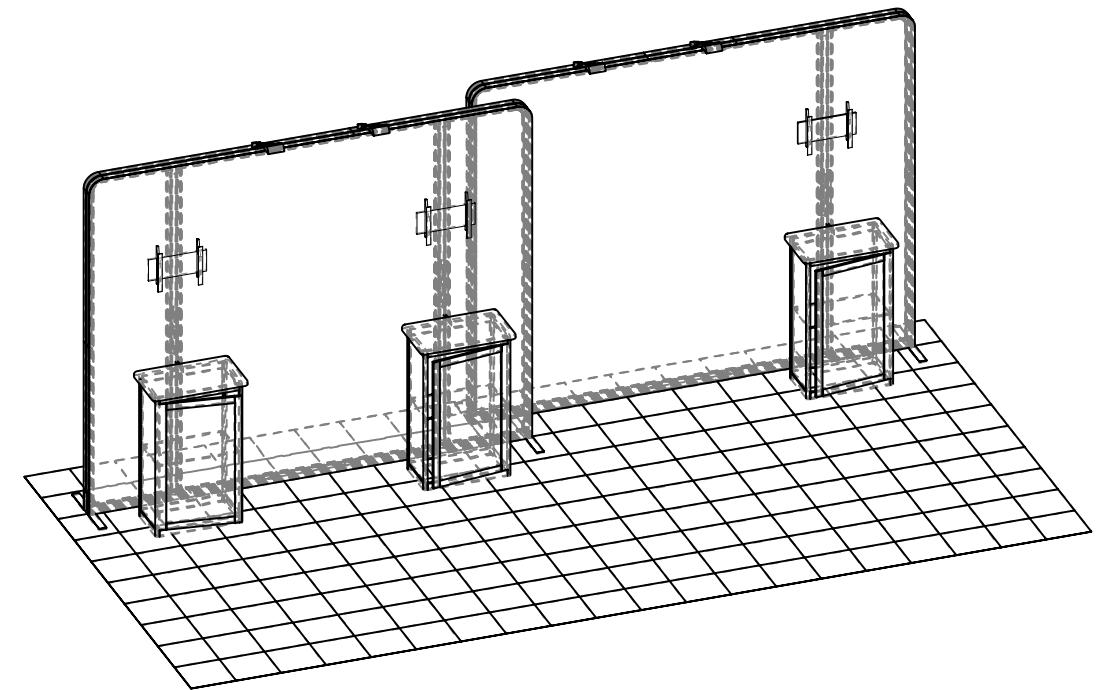
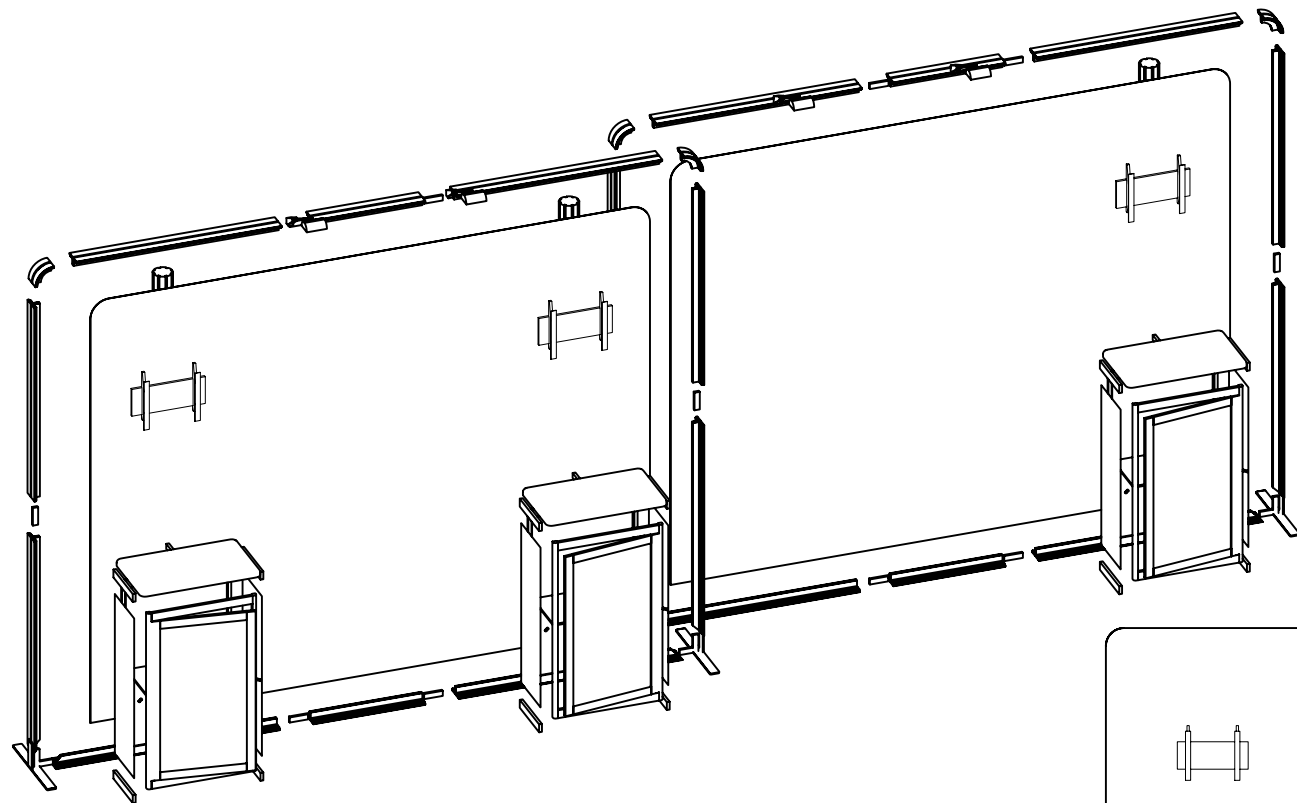
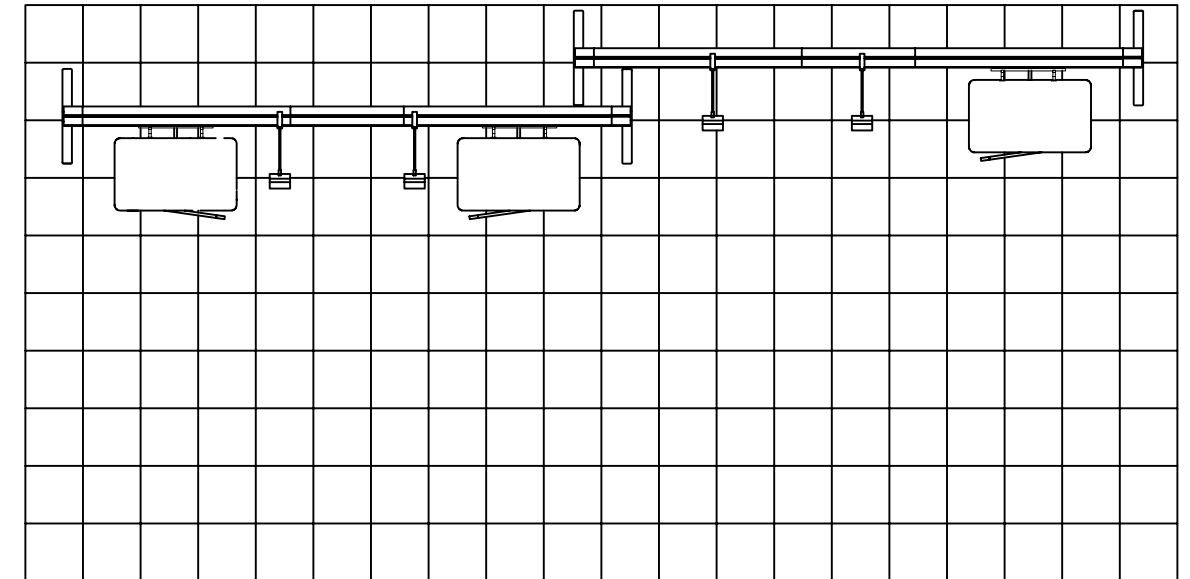

1. Redesign of this exhibit without approval by manufacturer may result in dangerous and unsafe structures. Manufacturer disclaims any responsibility for redesigned exhibits it does not approve in writing.

2. Parts and components such as panels and extrusions are manufactured to metric sizing. Where ever possible sizes have been noted in feet and inches as well as in metric. Below is the imperial to metric sizing table as reference. "Nominal" refers to approximate size.

- 2400mm = (94 1/2")
- 2100mm = (82 5/8")
- 1800mm = (70 7/8")
- 1500mm = (59")
- 1200mm = (47 1/4")
- 900mm = (35 1/2")
- 600mm = (23 5/8")
- 300mm = (11 7/8")

- ☒ Phone Line / Fax
- ☒ Internet connection
- ☒ Outlet
- ☒ Main Drop (point of distrution)

--- Wire running under carpet

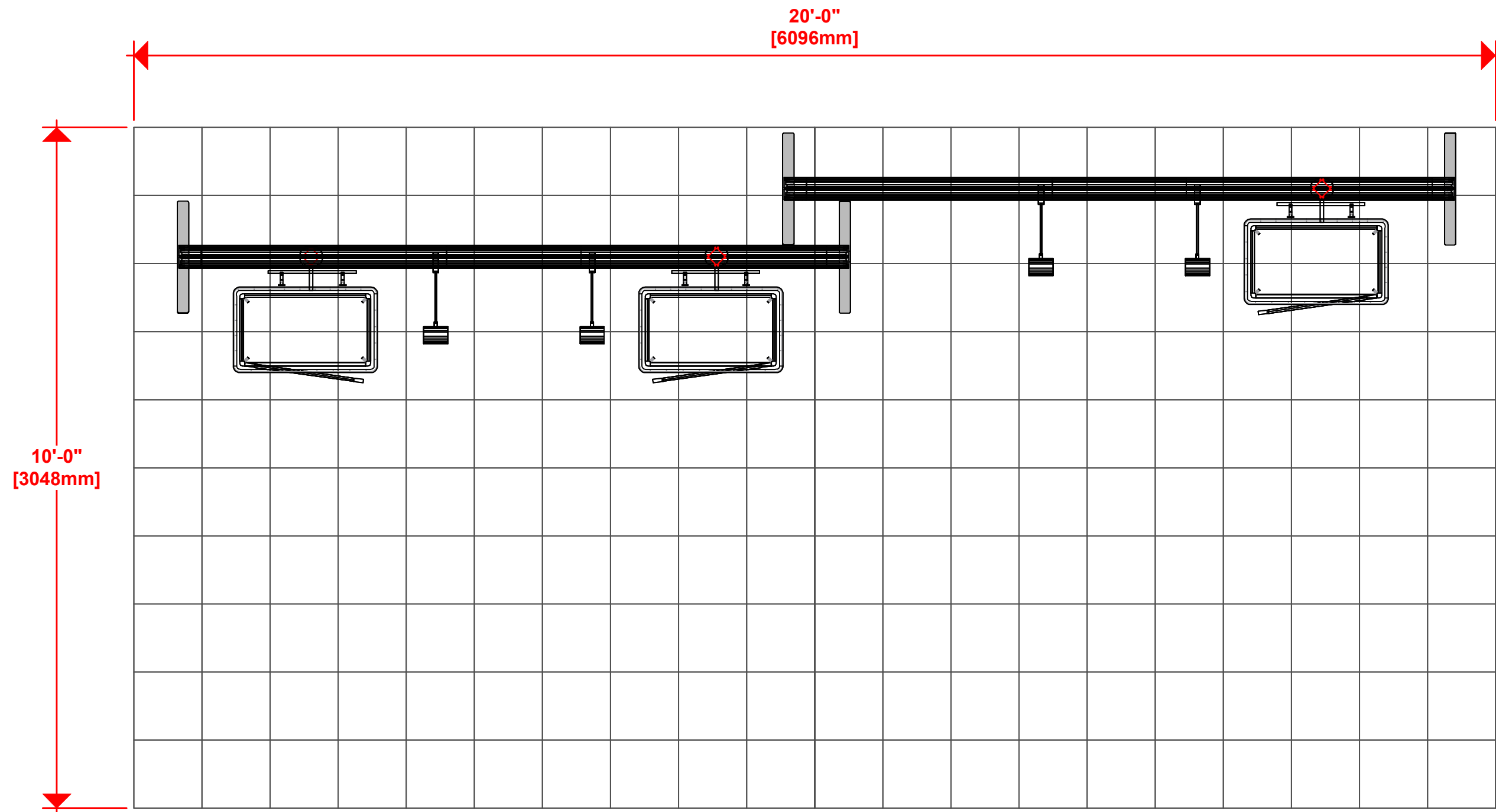

(4) LED L10S LIGHTS = 50W PER STICK

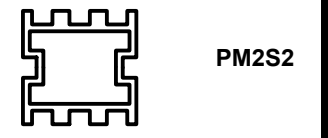

PM2S2

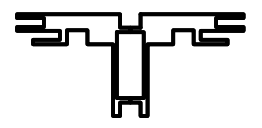

PHFC4

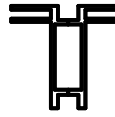

PHFC2



PH



PH4SC

HYBRID PRO RENTAL KIT

Title: SET-UP INSTRUCTIONS

EP

Code	#	Description
SW-FOOT	2	SMARTWALL SUPPORT FOOT
R10	4	1200MM (47.24") PHFC4 EXTRUSION WITH MITRE CUT 1 END FOR CB9 ONE END-IB2 HOL
R45	4	1100MM (43.31") PHFC4 EXTRUSION WITH IB2 LOCK HOLES ONE SIDE-LOCK ONE SIDE
CB9	2	CB9 CORNER BRACKET
IB2	6	INLINE BRACKET CONNECTOR
CB9R100	2	100MM ROUND PHCF4 CORNER BRACKET
R46	2	600MM (23.62") PHFC4 EXTRUSION WITH IB2 HOLES BOTH ENDS
R12	4	1155MM (45.47") 100MM PM4R8 ROUND EXTRUSION WITH LOCKS 1 END WITH PH2 STOP
R14	2	300MM (11.81") PM4D CONNECTOR WITH TENSION GLIDES
LN-100	2	JOINING BAR

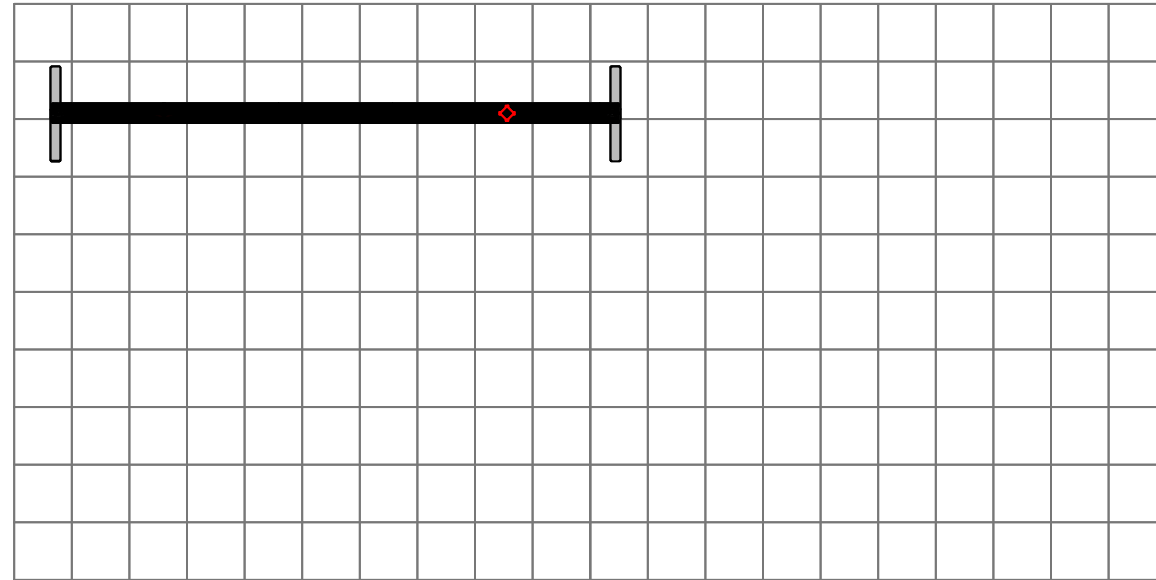

1. Redesign of this exhibit without approval by manufacturer may result in dangerous and unsafe structures. Manufacturer disclaims any responsibility for redesigned exhibits it does not approve in writing.

2. Parts and components such as panels and extrusions are manufactured to metric sizing. Where ever possible sizes have been noted in feet and inches as well as in metric. Below is the imperial to metric sizing table as reference. "Nominal" refers to approximate size.

2400mm = (94 1/2")	Phone Line / Fax
2100mm = (82 5/8")	Internet connection
1800mm = (70 7/8")	Outlet
1500mm = (59")	Main Drop (point of distrution)
1200mm = (47 1/4")	
900mm = (35 1/2")	
600mm = (23 5/8")	
300mm = (11 7/8")	

--- Wire running under carpet

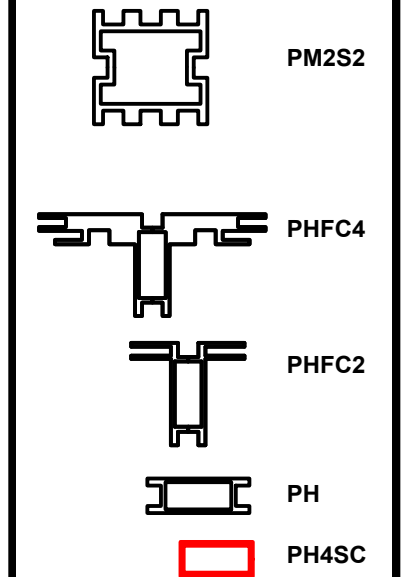
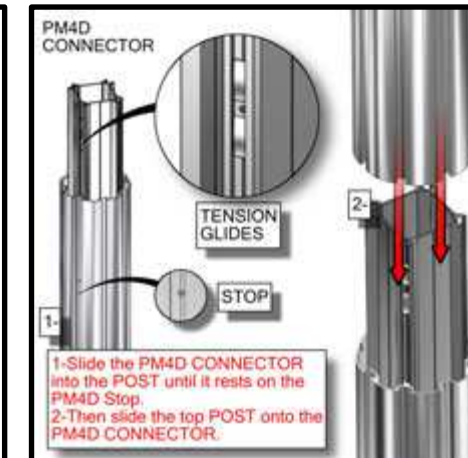
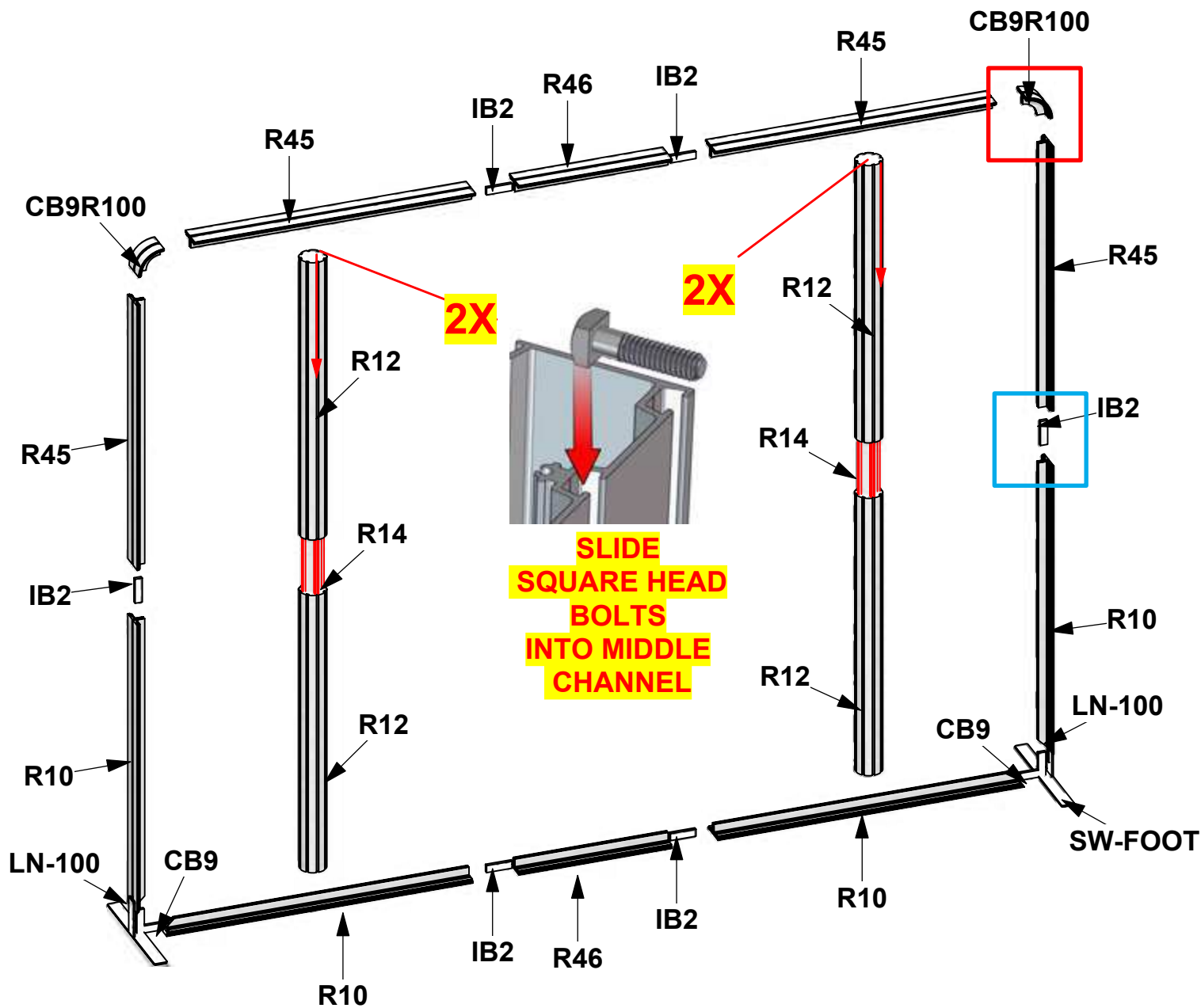

HYBRID PRO RENTAL KIT

Title: SET-UP INSTRUCTIONS

Code	#	Description
SW-FOOT	2	SMARTWALL SUPPORT FOOT
R10	4	1200MM (47.24") PHFC4 EXTRUSION WITH MITRE CUT 1 END FOR CB9 ONE END-IB2
R45	4	1100MM (43.31") PHFC4 EXTRUSION WITH IB2 LOCK HOLES ONE SIDE-LOCK ONE SI
CB9	2	CB9 CORNER BRACKET
IB2	6	INLINE BRACKET CONNECTOR
CB9R100	2	100MM ROUND PHCF4 CORNER BRACKET
R46	2	600MM (23.62") PHFC4 EXTRUSION WITH IB2 HOLES BOTH ENDS
R12	2	1155MM (45.47") 100MM PM4R8 ROUND EXTRUSION WITH LOCKS 1 END WITH PH2 S
R14	1	300MM (11.81") PM4D CONNECTOR WITH TENSION GLIDES
LN-100	2	JOINING BAR

1. Redesign of this exhibit without approval by manufacturer may result in dangerous and unsafe structures. Manufacturer disclaims any responsibility for redesigned exhibits it does not approve in writing.

2. Parts and components such as panels and extrusions are manufactured to metric sizing. Where ever possible sizes have been noted in feet and inches as well as in metric. Below is the imperial to metric sizing table as reference. "Nominal" refers to approximate size.

2400mm = (94 1/2")	Phone Line / Fax
2100mm = (82 5/8")	Internet connection
1800mm = (70 7/8")	Outlet
1500mm = (59")	Main Drop (point of distrution)
1200mm = (47 1/4")	
900mm = (35 1/2")	
600mm = (23 5/8")	
300mm = (11 7/8")	

--- Wire running under carpet

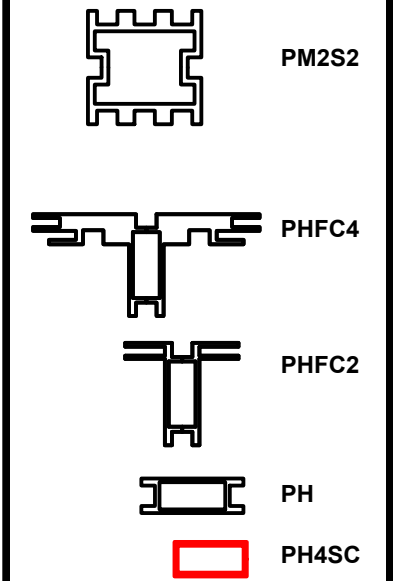
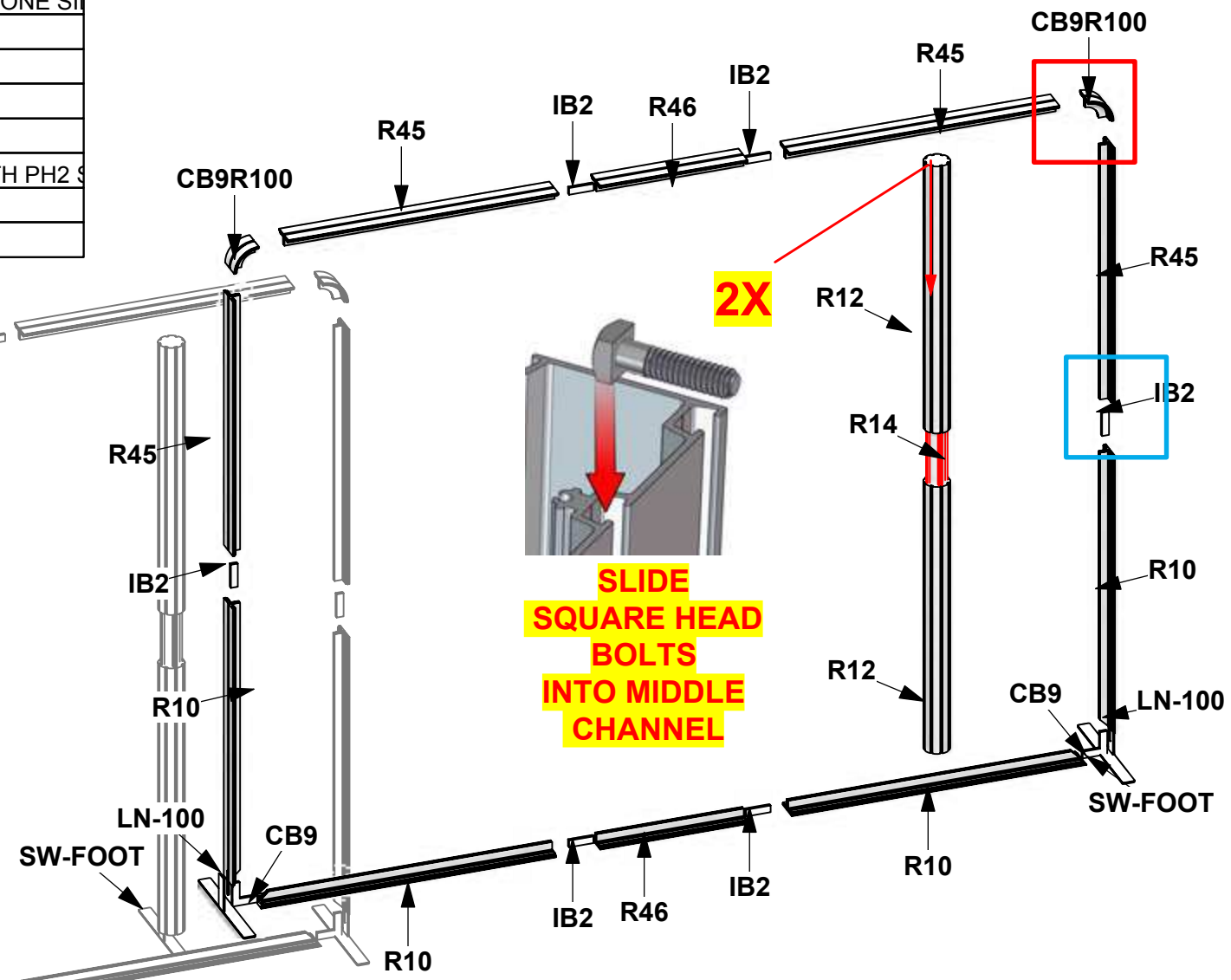
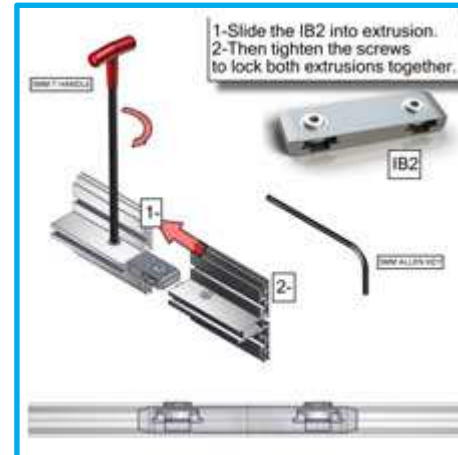
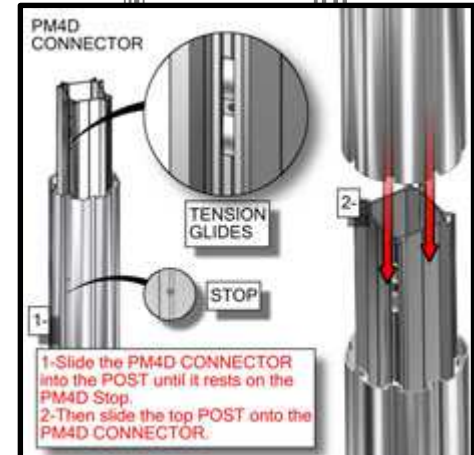
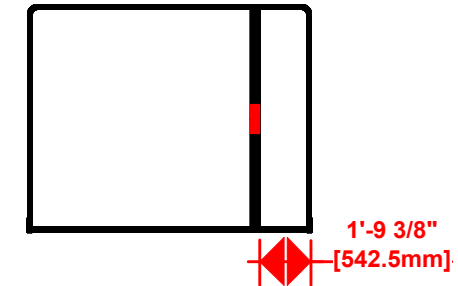

HYBRID PRO RENTAL KIT

Title: SET-UP INSTRUCTIONS

Code	#	Description
GRAPHIC A	1	94 1/2" (H) X 118 1/8" (W) SINGLE SIDED DYESUB GRAPHIC W/ FCE-2 (SEG) ON
MM-MB	3	MEDIUM MONITOR BRACKET FOR MONITORS 15"-40"
R48	3	100MM (3.94") PH1 EXTRUSION WITH LOCKS 2 ENDS
GRAPHIC B	1	94 1/2" (H) X 118 1/8" (W) SINGLE SIDED DYESUB GRAPHIC W/ FCE-2 (SEG) ON

1. Redesign of this exhibit without approval by manufacturer may result in dangerous and unsafe structures. Manufacturer disclaims any responsibility for redesigned exhibits it does not approve in writing.

2. Parts and components such as panels and extrusions are manufactured to metric sizing. Where ever possible sizes have been noted in feet and inches as well as in metric. Below is the imperial to metric sizing table as reference. "Nominal" refers to approximate size.

2400mm = (94 1/2")	Phone Line / Fax
2100mm = (82 5/8")	Internet connection
1800mm = (70 7/8")	Outlet
1500mm = (59")	Main Drop (point of distrution)
1200mm = (47 1/4")	
900mm = (35 1/2")	
600mm = (23 5/8")	
300mm = (11 7/8")	

--- Wire running under carpet

FCE-2 TO PHFC4

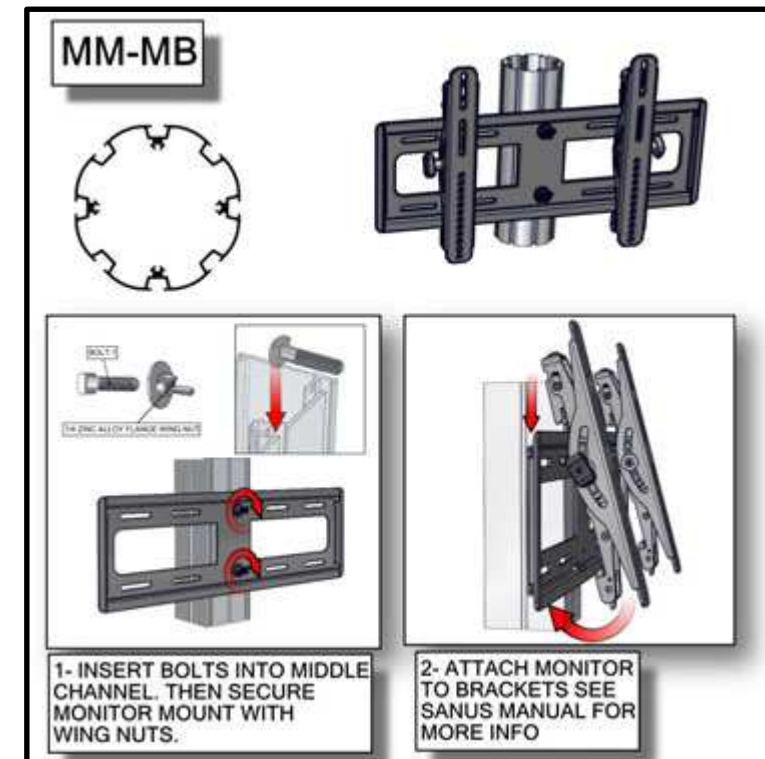
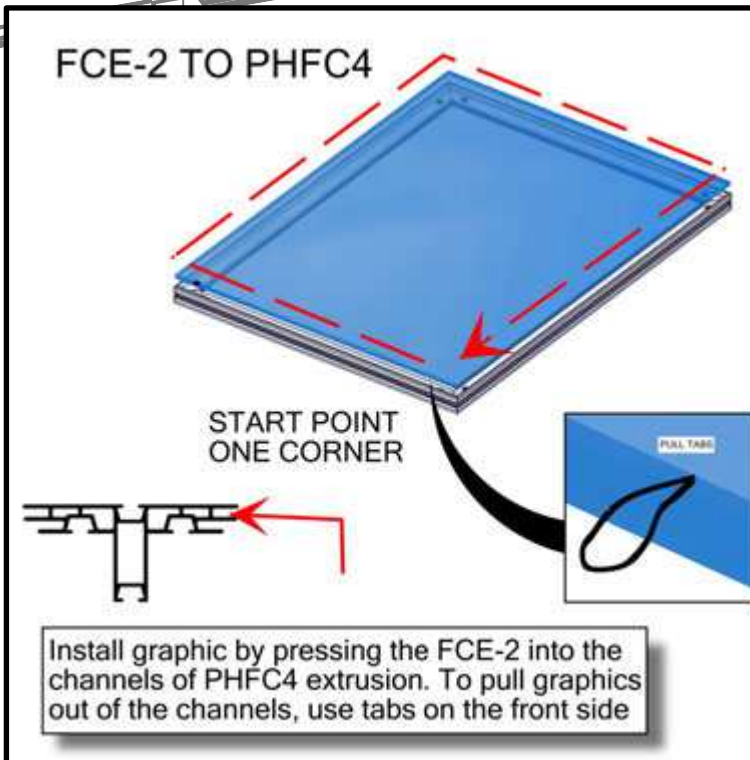
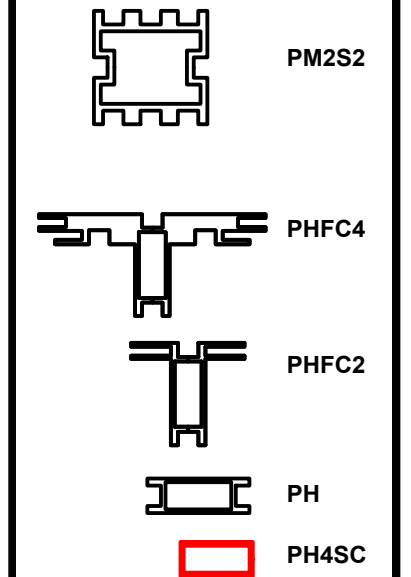
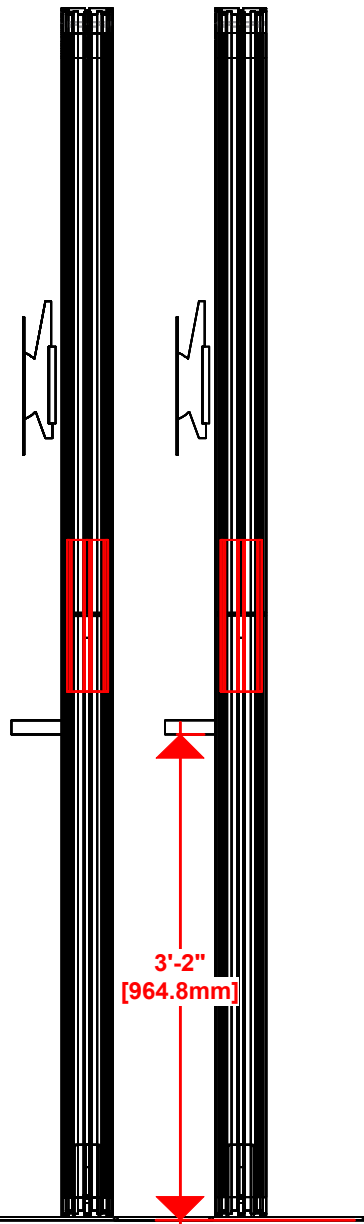
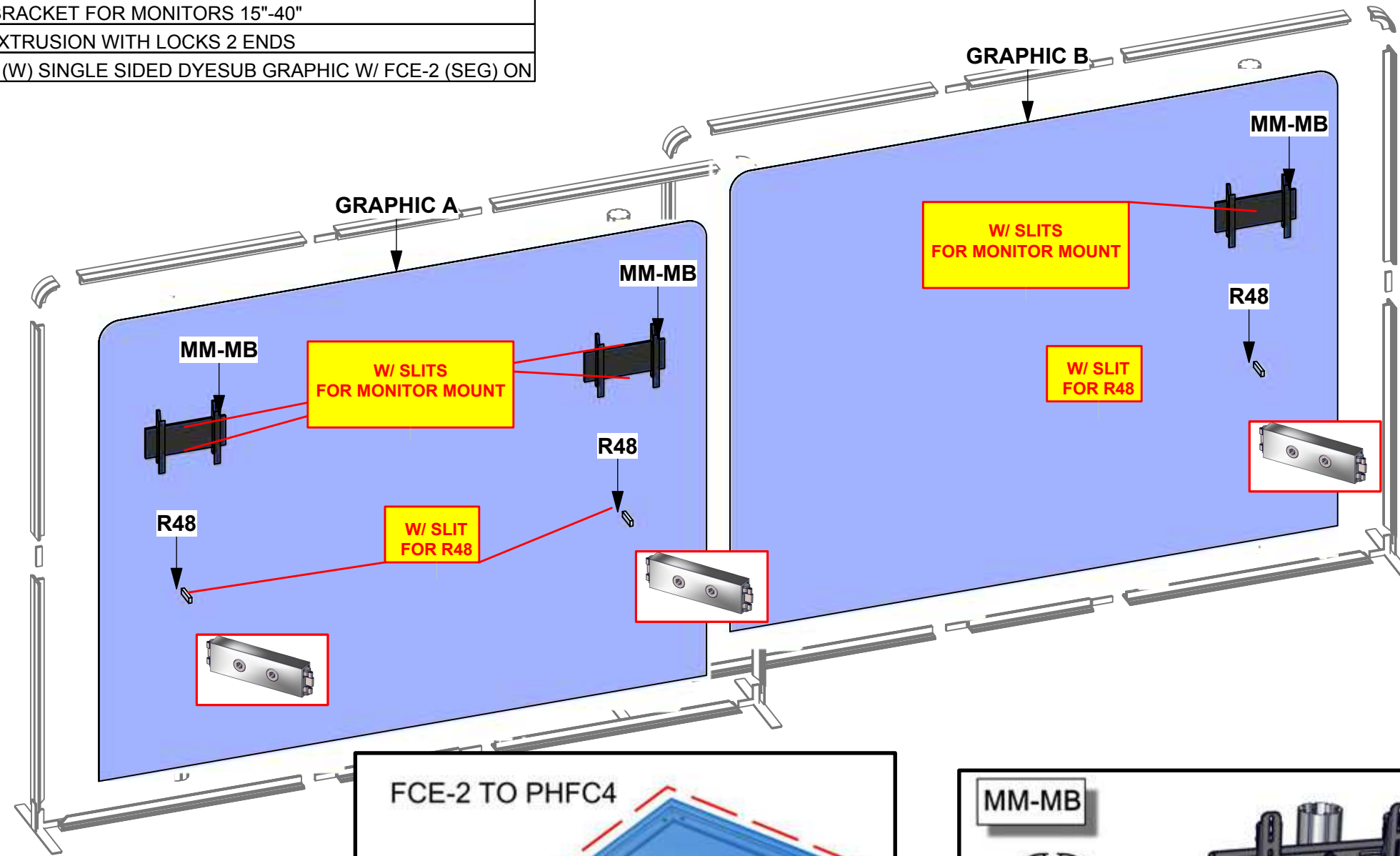
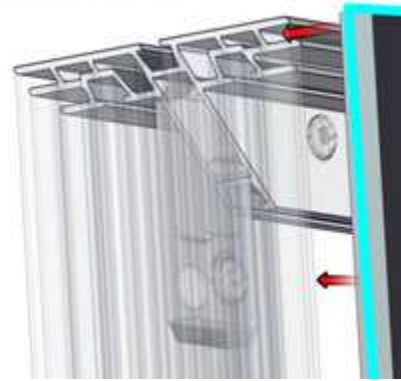

HYBRID PRO RENTAL KIT

Title: SET-UP INSTRUCTIONS

Code	#	Description
LEDL10S	4	LED SPOTLIGHT,3M,UL PLUG W/TRANSFORMER SILVER

1. Redesign of this exhibit without approval by manufacturer may result in dangerous and unsafe structures. Manufacturer disclaims any responsibility for redesigned exhibits it does not approve in writing.

2. Parts and components such as panels and extrusions are manufactured to metric sizing. Where ever possible sizes have been noted in feet and inches as well as in metric. Below is the imperial to metric sizing table as reference. "Nominal" refers to approximate size.

2400mm = (94 1/2")	Phone Line / Fax
2100mm = (82 5/8")	Internet connection
1800mm = (70 7/8")	Outlet
1500mm = (59")	Main Drop (point of distrution)
1200mm = (47 1/4")	
900mm = (35 1/2")	
600mm = (23 5/8")	
300mm = (11 7/8")	

--- Wire running under carpet

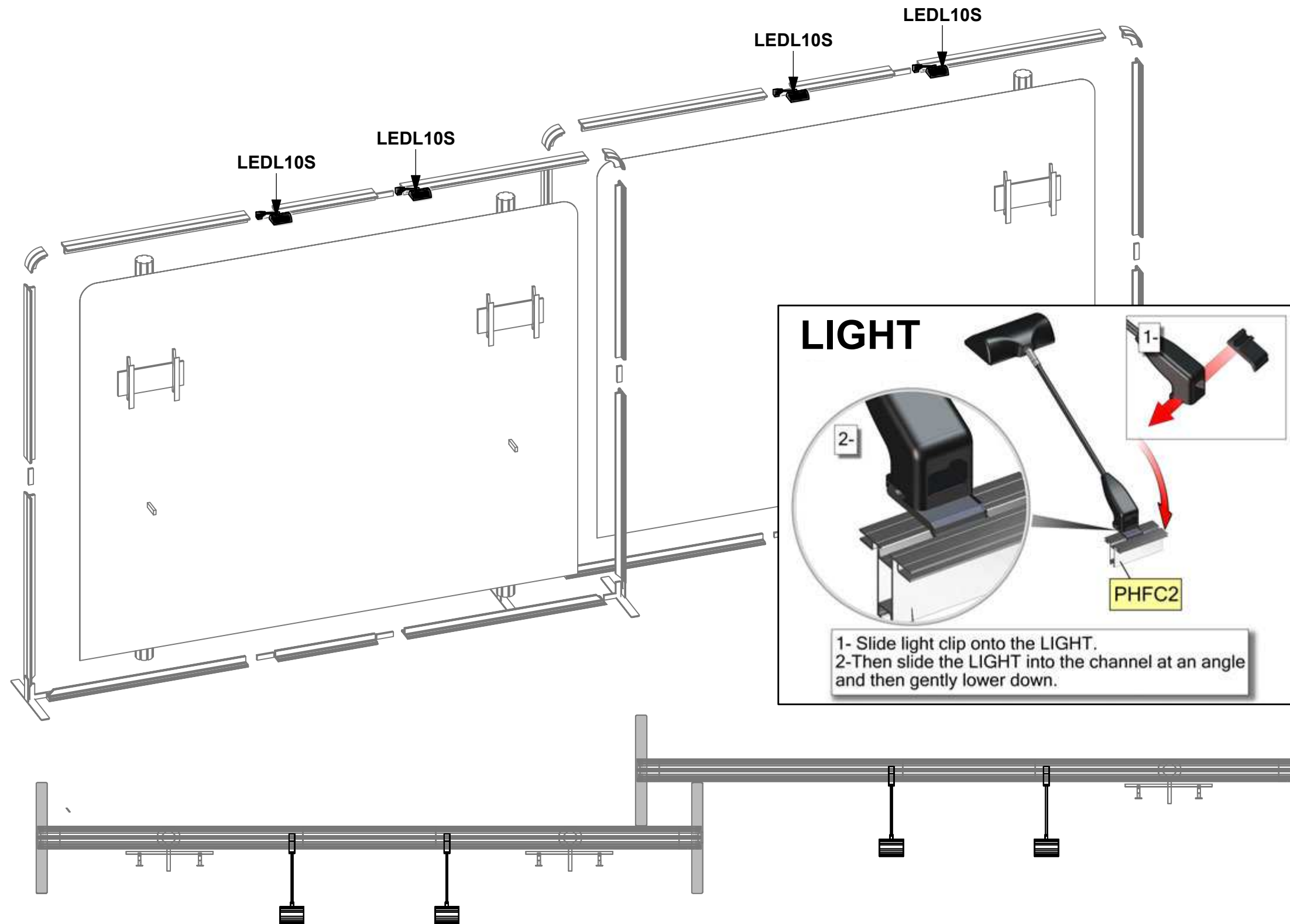

	PM2S2
	PHFC4
	PHFC2
	PH
	PH4SC

HYBRID PRO RENTAL KIT

Title: SET-UP INSTRUCTIONS

Code	#	Description
R50	6	280MM (11") PH WITH SLIDE LOCK AT BOTH ENDS
R53	3	581MM X 1000MM (22 7/8" X 39 3/8") FRONT FRAME W/GFX INFILL W/SLIT
R52	3	581MM X 1000MM (22 7/8" X 39 3/8") CABINET DOOR W/GFX INFILL
GRAPHIC D	1	922MM X 292MM (36 5/16" X 11 1/2") SIDE SINTRA/FOAMEX

1. Redesign of this exhibit without approval by manufacturer may result in dangerous and unsafe structures. Manufacturer disclaims any responsibility for redesigned exhibits it does not approve in writing.

2. Parts and components such as panels and extrusions are manufactured to metric sizing. Where ever possible sizes have been noted in feet and inches as well as in metric. Below is the imperial to metric sizing table as reference. "Nominal" refers to approximate size.

- 2400mm = (94 1/2") Phone Line / Fax
 - 2100mm = (82 5/8") Internet connection
 - 1800mm = (70 7/8") Outlet
 - 1500mm = (59") Main Drop (point of distrution)
 - 1200mm = (47 1/4")
 - 900mm = (35 1/2")
 - 600mm = (23 5/8")
 - 300mm = (11 7/8")
- Wire running under carpet

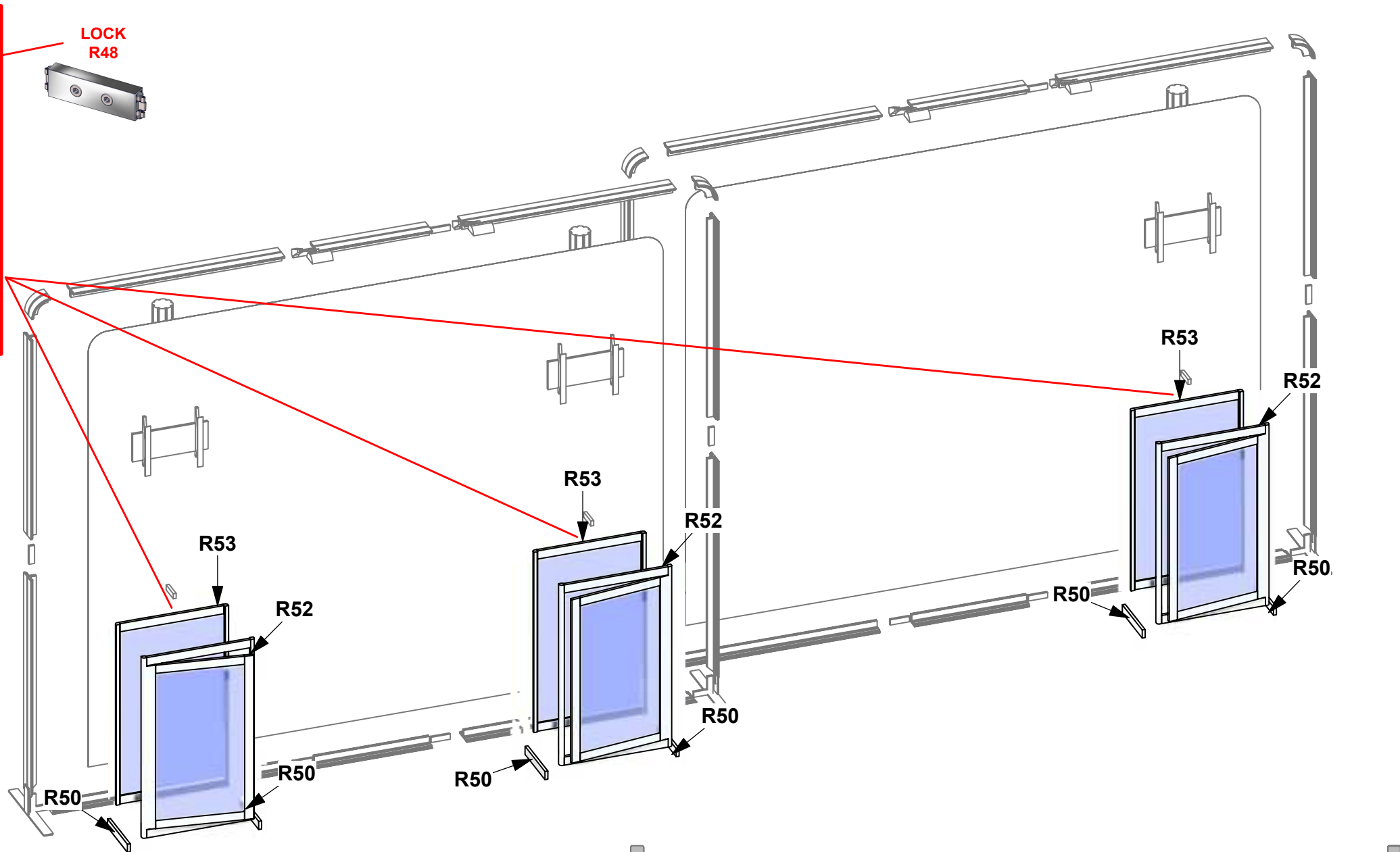
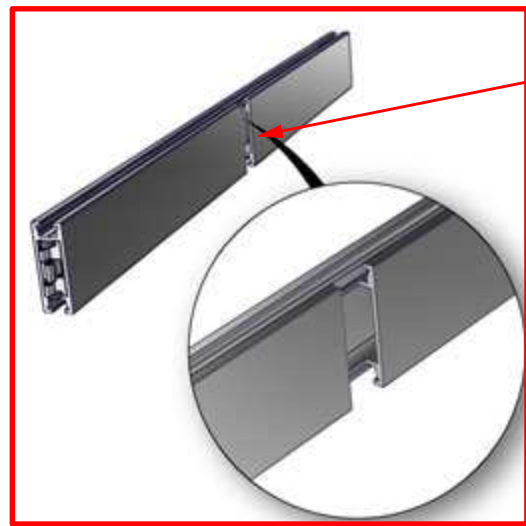

WARNING!
Locks should ONLY be turned a half (or quarter) turn so as not to STRIP the locks by over torquing them

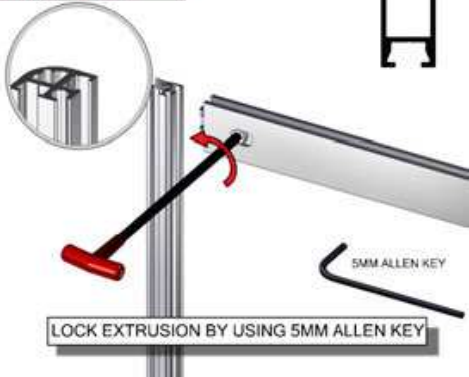

- PM2S2
- PHFC4
- PHFC2
- PH
- PH4SC

HYBRID PRO RENTAL KIT

Title: SET-UP INSTRUCTIONS

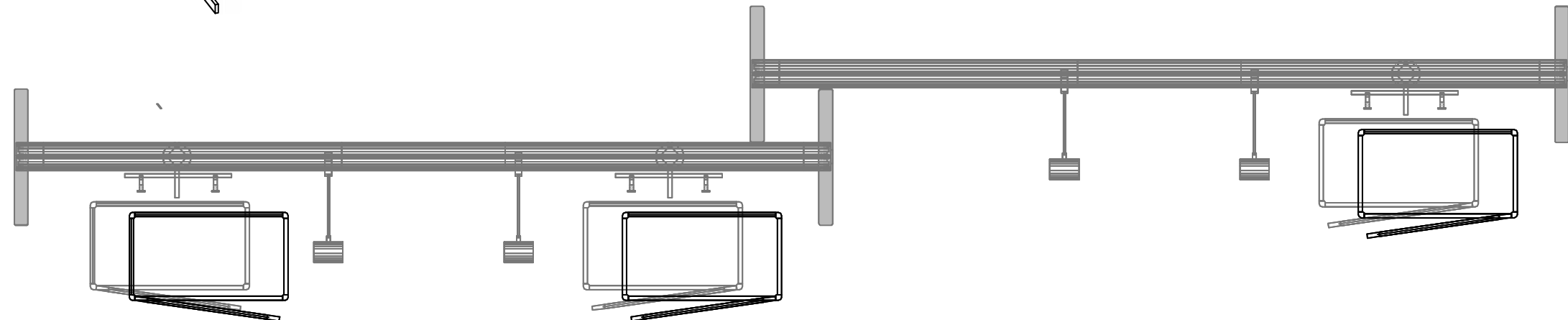

Code	#	Description
INT SHELF	3	292MM X 553 (11 1/2" X 21 3/4") INTERNAL SHELF FOR V-CU-CAB-01
R50	6	280MM (11") PH WITH SLIDE LOCK AT BOTH ENDS
GRAPHIC D	5	922MM X 292MM (36 5/16" X 11 1/2") SIDE SINTRA/FOAMEX
V-SS1	12	SHELF SUPPORT

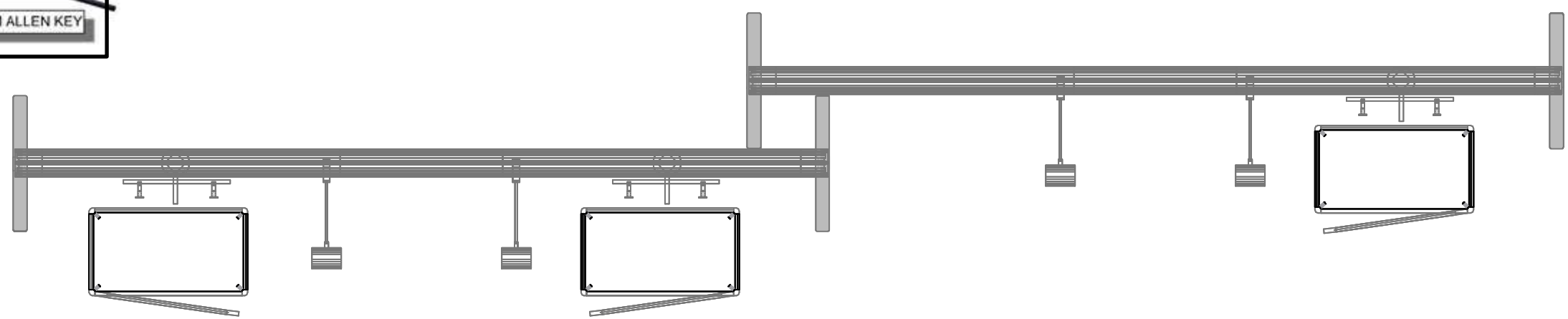
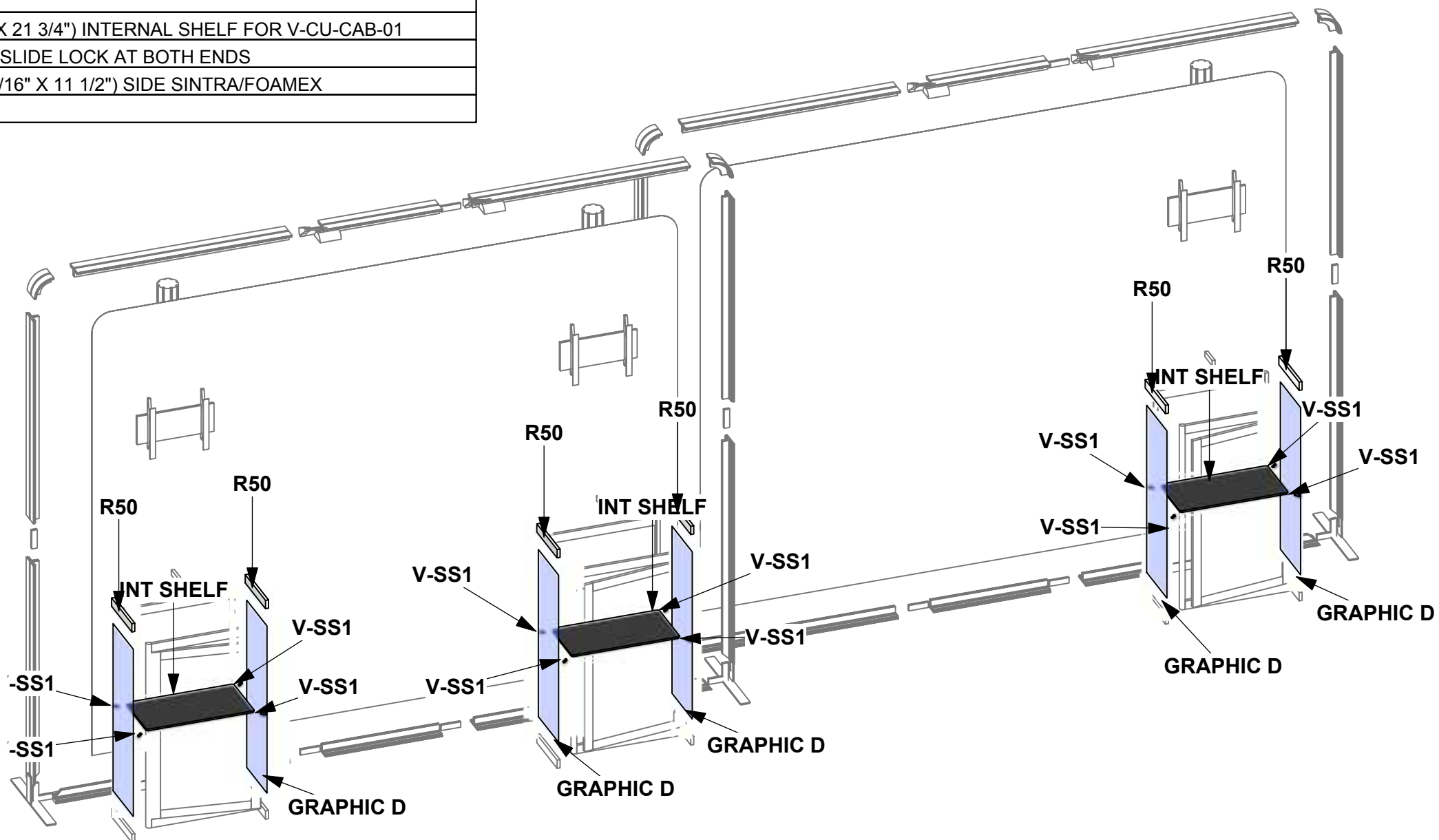
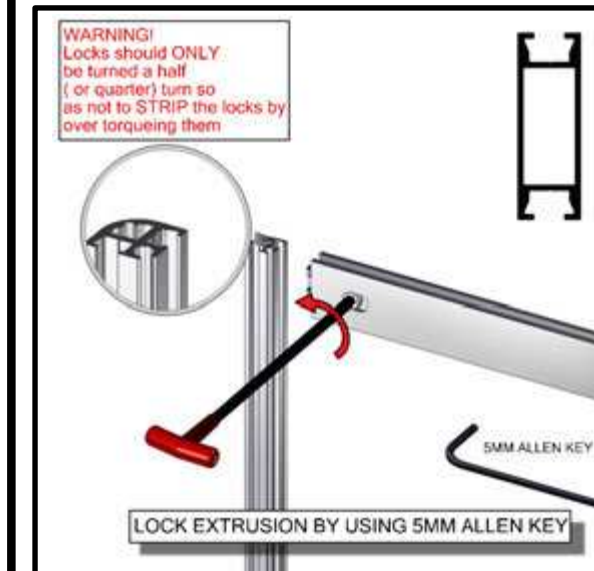
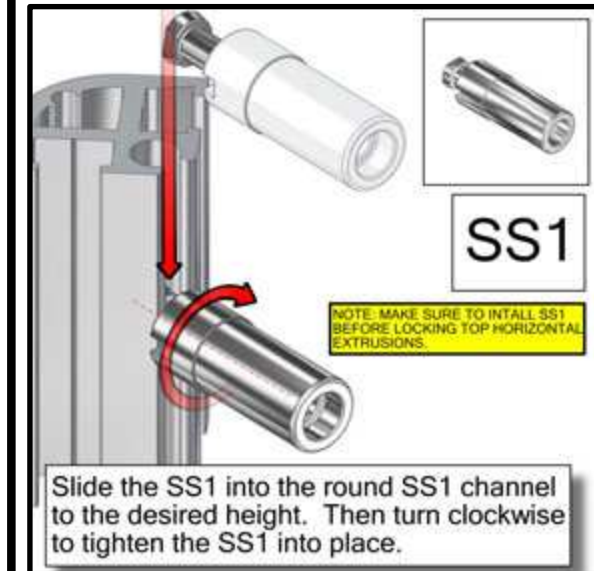

1. Redesign of this exhibit without approval by manufacturer may result in dangerous and unsafe structures. Manufacturer disclaims any responsibility for redesigned exhibits it does not approve in writing.

2. Parts and components such as panels and extrusions are manufactured to metric sizing. Where ever possible sizes have been noted in feet and inches as well as in metric. Below is the imperial to metric sizing table as reference. "Nominal" refers to approximate size.

2400mm = (94 1/2")	Phone Line / Fax
2100mm = (82 5/8")	Internet connection
1800mm = (70 7/8")	Outlet
1500mm = (59")	Main Drop (point of distrution)
1200mm = (47 1/4")	
900mm = (35 1/2")	
600mm = (23 5/8")	
300mm = (11 7/8")	

--- Wire running under carpet

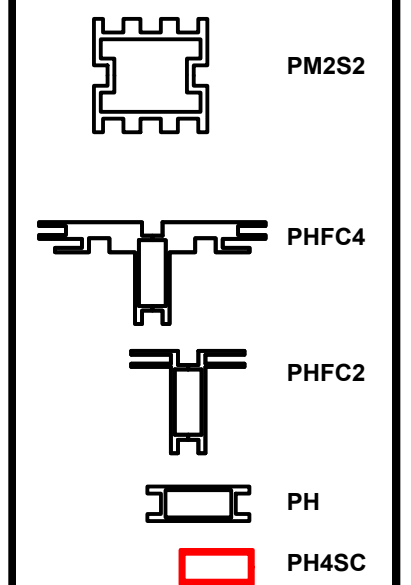

HYBRID PRO RENTAL KIT

Title: SET-UP INSTRUCTIONS

Code	#	Description
V-CW-CT-0	3	384MM X 646MM (15 1/8" X 25 7/16") HYBRID RECTANGLE TOP

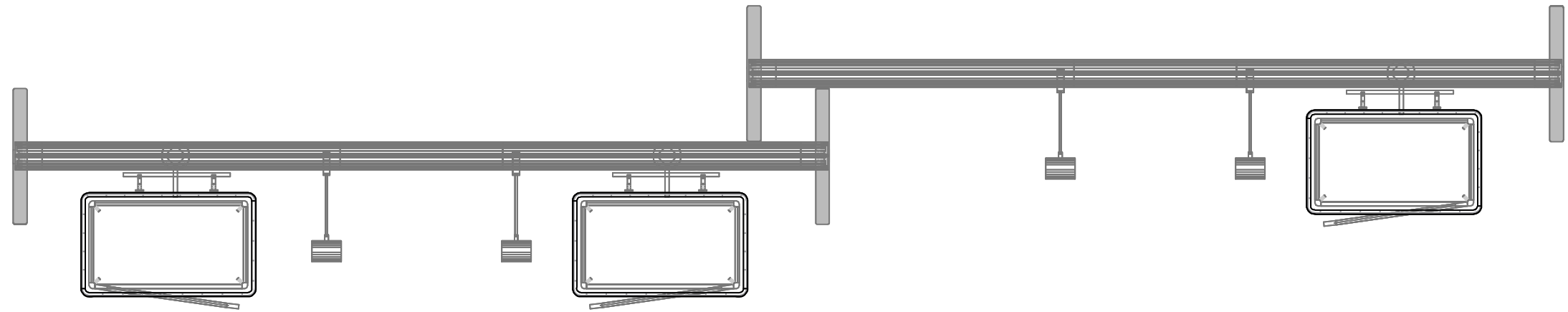
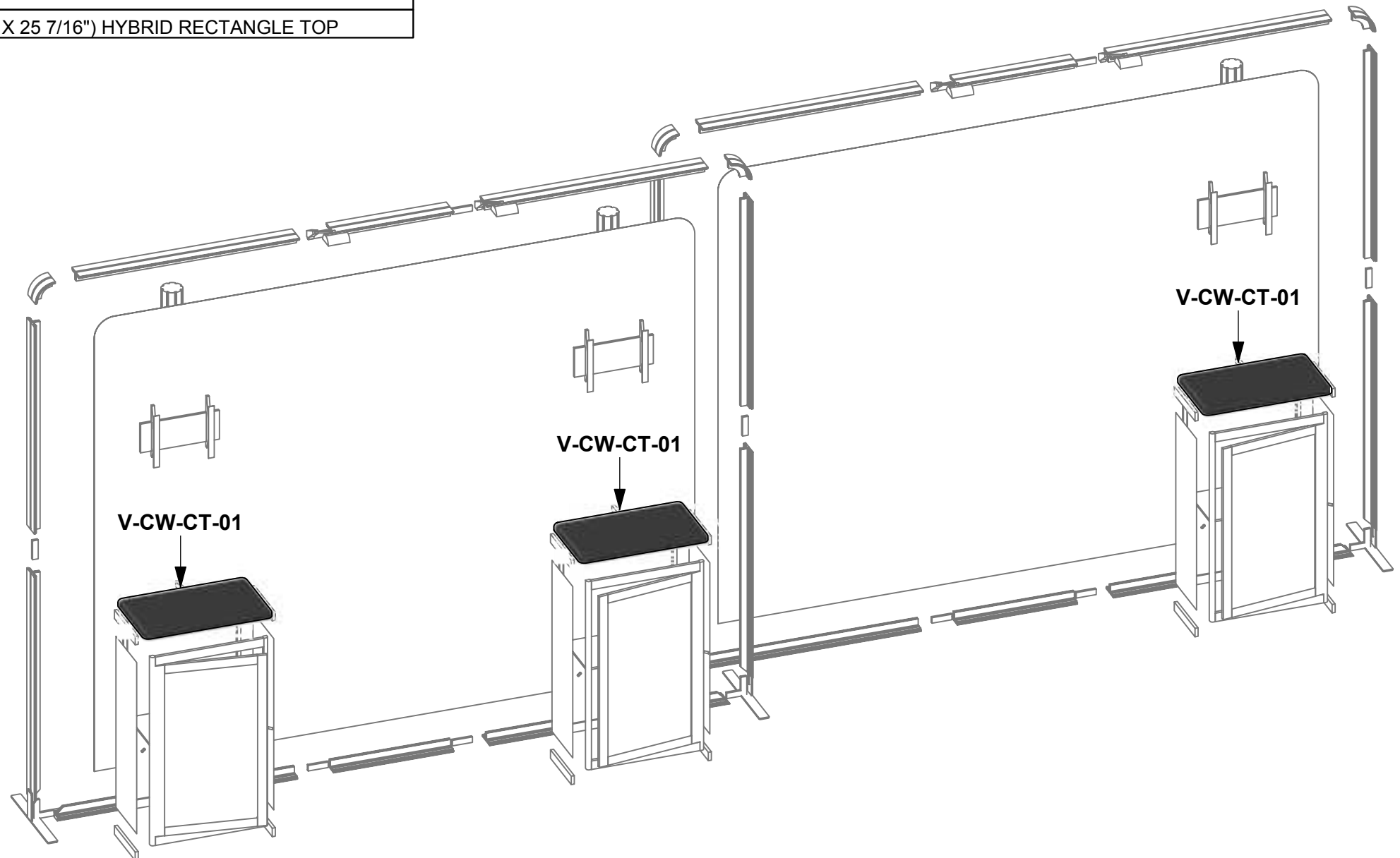

1. Redesign of this exhibit without approval by manufacturer may result in dangerous and unsafe structures. Manufacturer disclaims any responsibility for redesigned exhibits it does not approve in writing.

2. Parts and components such as panels and extrusions are manufactured to metric sizing. Where ever possible sizes have been noted in feet and inches as well as in metric. Below is the imperial to metric sizing table as reference. "Nominal" refers to approximate size.

2400mm = (94 1/2")	Phone Line / Fax
2100mm = (82 5/8")	Internet connection
1800mm = (70 7/8")	Outlet
1500mm = (59")	Main Drop (point of distrution)
1200mm = (47 1/4")	
900mm = (35 1/2")	
600mm = (23 5/8")	
300mm = (11 7/8")	

--- Wire running under carpet

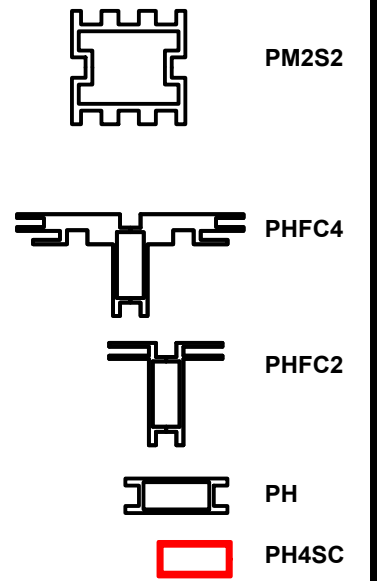

HYBRID PRO RENTAL KIT

Title: SET-UP INSTRUCTIONS

PACKING INSTRUCTIONS



2



4



1



3

HARDWARE BOX

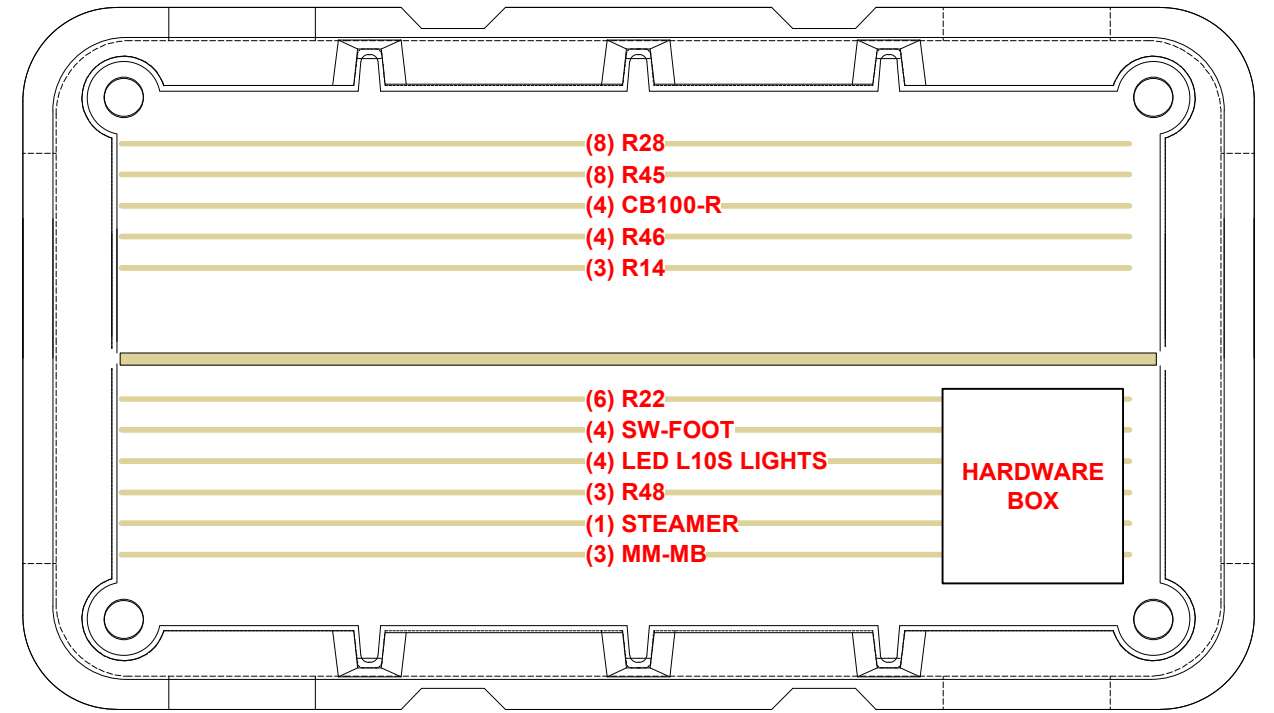

CASE # 1

LEGEND	
	GREY FOAM FOLDED TO FILL EMPTY SPACES OR USED AS PROTECTION
	1/8" CARDBOARD SPACER (PUT IN BETWEEN EVERY PANEL)
	DIVIDER
	1/4" WHITE FOAM (USED AS PROTECTION DOOR PANELS W/ LOCKS)

INTERNAL DIMS 49"L X 24.5"W X 51"H
 EXTERNAL DIMS 59"L X 34"W X 57"H

SCRATE



(3) R52



(3) INTERNAL SHELVES,
(3) R53



(3) V-CW-CT-01

CASE # 2

LEGEND		GREY FOAM FOLDED TO FILL EMPTY SPACES OR USED AS PROTECTION
		1/8" CARDBOARD SPACER (PUT IN BETWEEN EVERY PANEL)
		DIVIDER
		1/4" WHITE FOAM (USED AS PROTECTION DOOR PANELS W/ LOCKS)

