

# Hybrid Pro Modular Kit 11

## HP-K-11

Hybrid Pro™ Modular exhibits and counters are a perfect solution for the serious exhibitor. Exhibits feature heavy-duty aluminum extrusion frames and push-fit fabric graphics. Count on making an unforgettable impact with Hybrid Pro Modular exhibit kits, counters, and accessories.



\* foreground counters not included

## features and benefits:

- Silver aluminum extrusion frame
- Illuminated SEG push-fit graphic panel with interior top and bottom LED lighting
- Single-sided SEG dye-sublimated push-fit fabric graphics
- Easy step-by-step instructions
- Kit includes frame, two side/top white accents, four fabric graphic panels, one illuminated graphic panel, two pillowcase fabric graphics, two counters, two medium monitor mounts, one SCRATE and two woodcrates
- Lifetime hardware warranty against manufacturer defects

## dimensions:

### Hardware

Assembled unit:  
222.75" w x 94.75" h x 19.63" d  
5657.85mm(w) x 2406.65(h) x 498.6mm(d)

Backwall Counters:  
21.75" w x 38" h x 17.75" d approx.  
552.45mm(w) x 965.2mm(h) x 450.85mm(d)  
\*Support 50 lbs / 22.68 kgs each

### Shipping

Shipping dimensions - ships in 3 cases:  
1 SCRATE case: 59" l x 57" h x 34" d  
1498.6mm(l) x 1447.8mm(h) x 863.6mm(d)

2 WOODCRATES: 48" l x 30" h x 27" d  
1219.2mm(l) x 762mm(h) x 685.8mm(d)

Approximate shipping weight (entire kit):  
835 lbs / 379 kgs

### Graphic

Total visual area:  
Panels B & F: 35.3" w x 82.54" h  
Panels C & E: 23.49" w x 70.73" h  
Panel D (backlit): 94.375" w x 94.375" h

Top (outside D): 61.93" w x 17.71" h  
Top (inside D): 60.722" w x 17.71" h

Side 1 (outside D): 90" w x 17.71" h  
Side 2 (inside D): 88.891" w x 17.71" h

\*We recommend that the inside be a pattern or solid color.

Please be sure to include a 2" bleed around the perimeter.



ZZZ FDPHOEDFNGLVSD\

## additional information:

Graphic material: Dye-sublimated fabric

Laminate cabinet with locking storage door and custom side/top laminate accent panel

Medium monitor bracket holds 26-40" LCD, maximum weight: 50lbs / 22.68 kgs

\*LCD monitors not included

\*Foreground counters not included

Laminate counter color options:

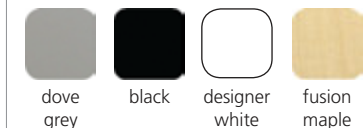

We are continually improving and modifying our product range and reserve the right to vary the specifications without prior notice. All dimensions and weights quoted are approximate and we accept no responsibility for variance. E&OE. See Graphic Templates for graphic bleed specifications.

R-HP-K-11

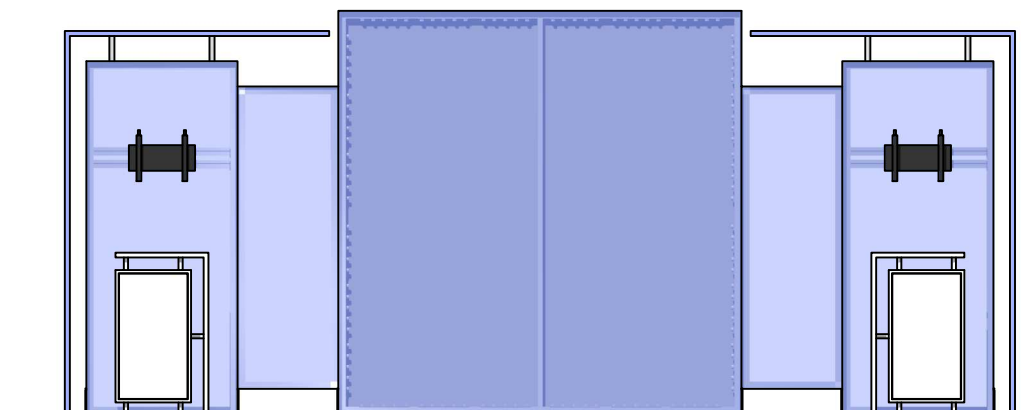
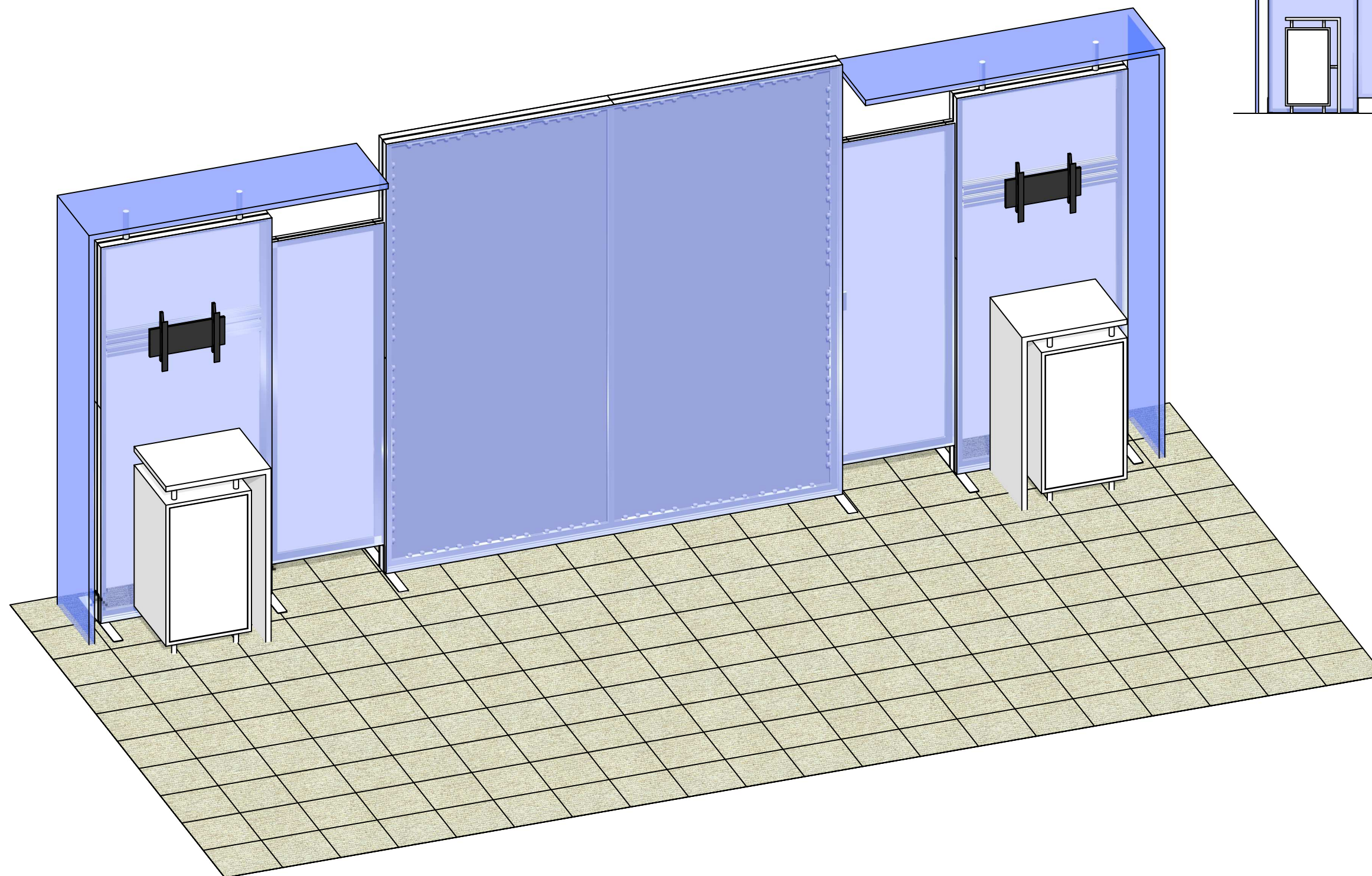

Code	#	Description
GRAPHIC B1	1	70 7/8" (H) X 23 5/8" (W) SINGLE SIDED DYESUB GRAPHIC W/ FCE-2 (SEG) ON PERIMETER
GRAPHIC B2	1	70 7/8" (H) X 23 5/8" (W) SINGLE SIDED DYESUB GRAPHIC W/ FCE-2 (SEG) ON PERIMETER
SW-FOOT	6	SMARTWALL SUPPORT FOOT
R10	12	1200MM (47.24") PHFC4 EXTRUSION WITH MITRE CUT 1 END FOR CB9 ONE END-IB2 HOLES ONE END
CB9	12	CB9 CORNER BRACKET
IB2	13	INLINE BRACKET CONNECTOR
R41	4	900MM (35.43") PHFC4 EXTRUSION WITH MITRE CUT 1 END FOR CB9 ONE END-IB2 HOLES ONE END
R26	4	900MM (35.43") PHFC4 EXTRUSION WITH MITRE CUT BOTH ENDS
GRAPHIC A1	1	82 11/16" (H) X 35 7/16" (W) SINGLE SIDED DYESUB GRAPHIC W/ FCE-2 (SEG) ON PERIMETER
GRAPHIC C	1	94 1/2" (H) X 94 1/2" (W) BACKLIT DYESUB GRAPHIC W/ FCE-2 (SEG) ON PERIMETER
MM-MB	2	MEDIUM MONITOR BRACKET FOR MONITORS 15"-40"
CKSO	4	1" X 1" STANDOFF
R42	4	810MM (31.89") 50MM PM2S 4 WAY SQUARE EXTRUSION WITH LOCKS 2 ENDS
R55	4	510MM (20.08") PHFC2 EXTRUSION WITH LOCKS 2 ENDS
GRAPHIC A2	1	82 11/16" (H) X 35 7/16" (W) SINGLE SIDED DYESUB GRAPHIC W/ FCE-2 (SEG) ON PERIMETER
UNPRINTED C	1	94 1/2" (H) X 94 1/2" (W) WHITE FABRIC W/ FCE-2 (SEG) ON PERIMETER
CB9-S	8	50MM SQUARE PHCF2 CORNER BRACKET
R43	8	855MM (33.66") PHFC2 EXTRUSION WITH LOCKS 2 ENDS WITH SIDE CAM LOCKS
LN-100	6	JOINING BAR
LED-WHT-DB-300	24	300MM (11.81") LENGTH LED LIGHTS FOR DIRECTIONAL BACKLIGHT
R7	2	1155MM (45.47") PH1 EXTRUSION WITH IB2 HOLE ONE SIDE-WITH LOCK 1 END
CUST FS	2	APPROX. 62" W X 90" H X 18" D CUSTOM L-SHAPED FABRIC STRUCTURE - FRAME ONLY

# BOM

R-HP-K-11

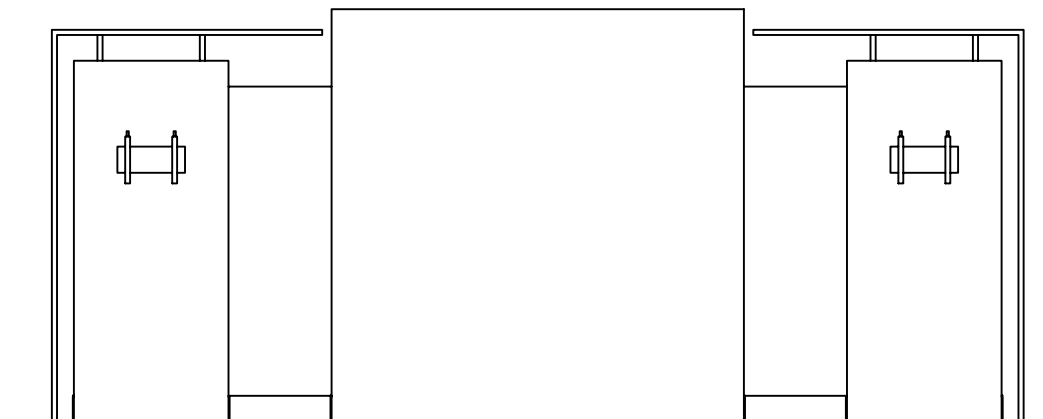
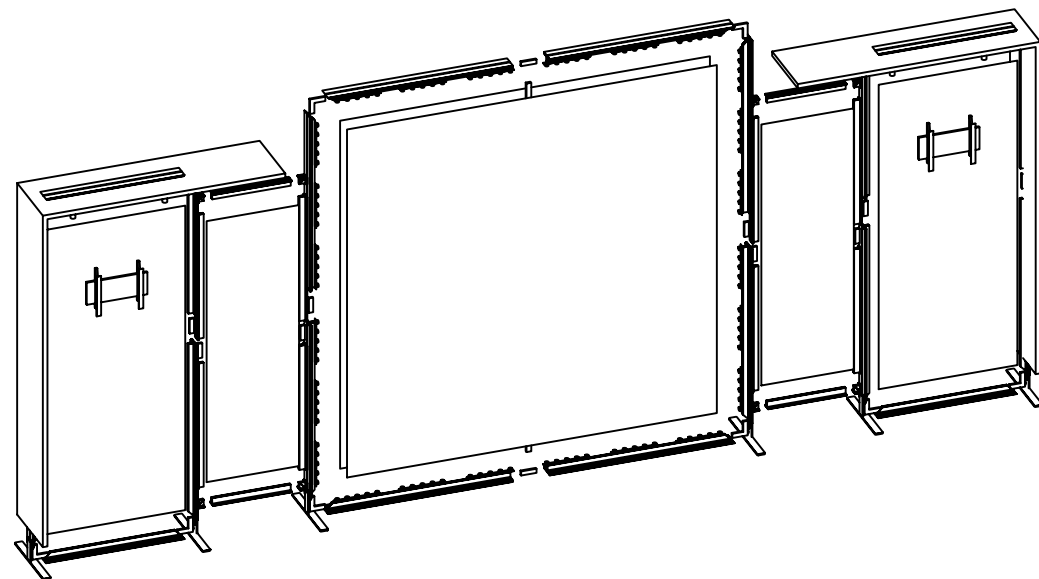
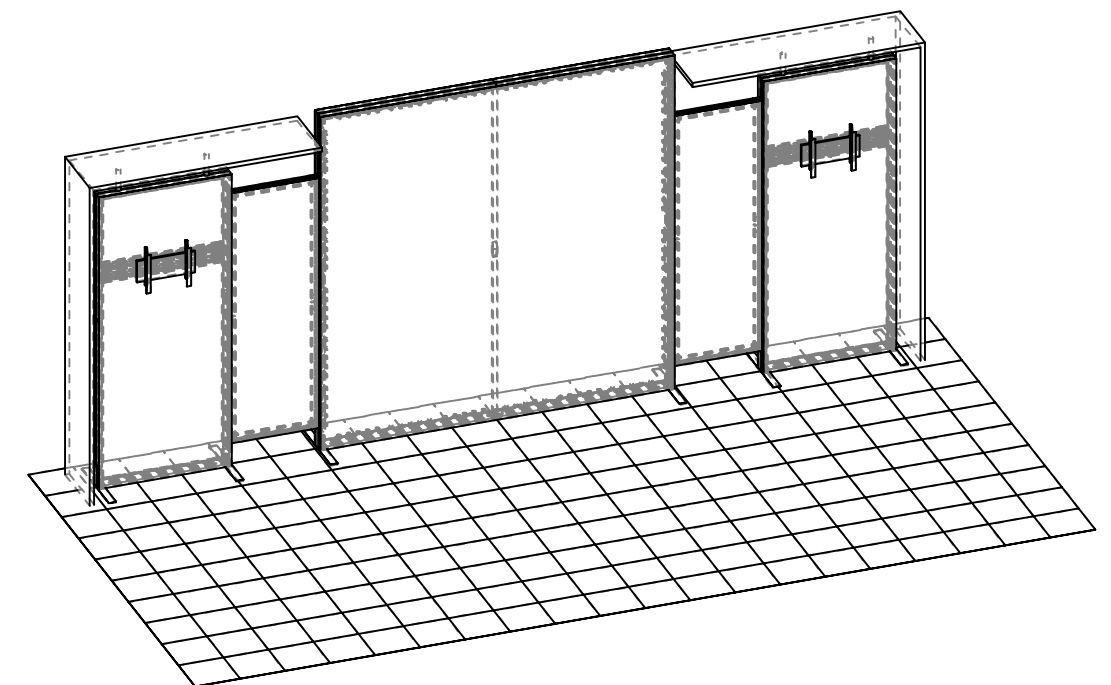
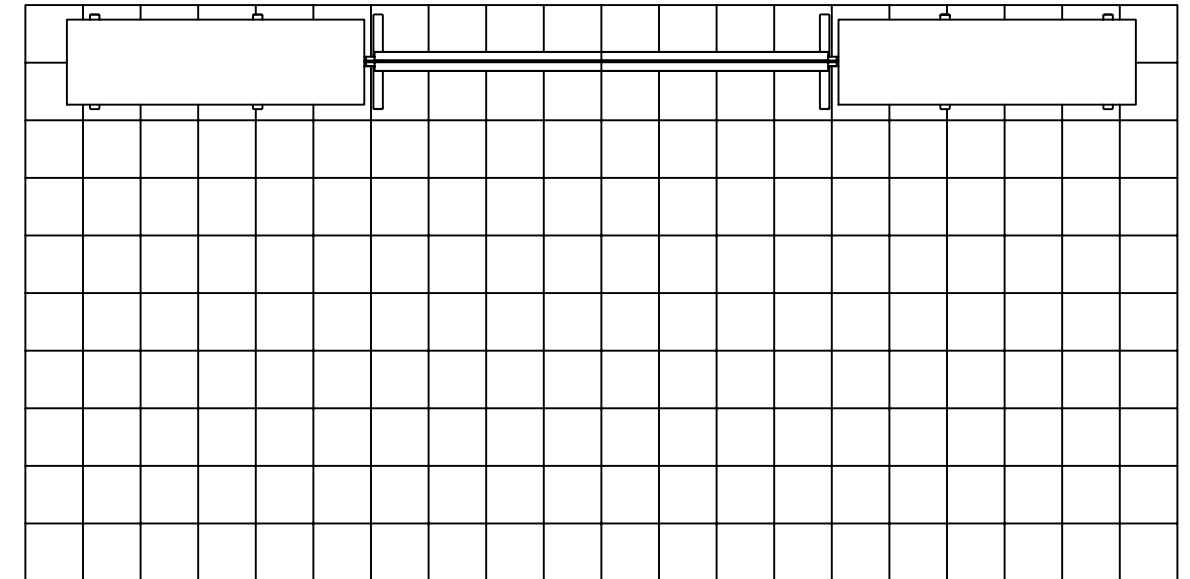



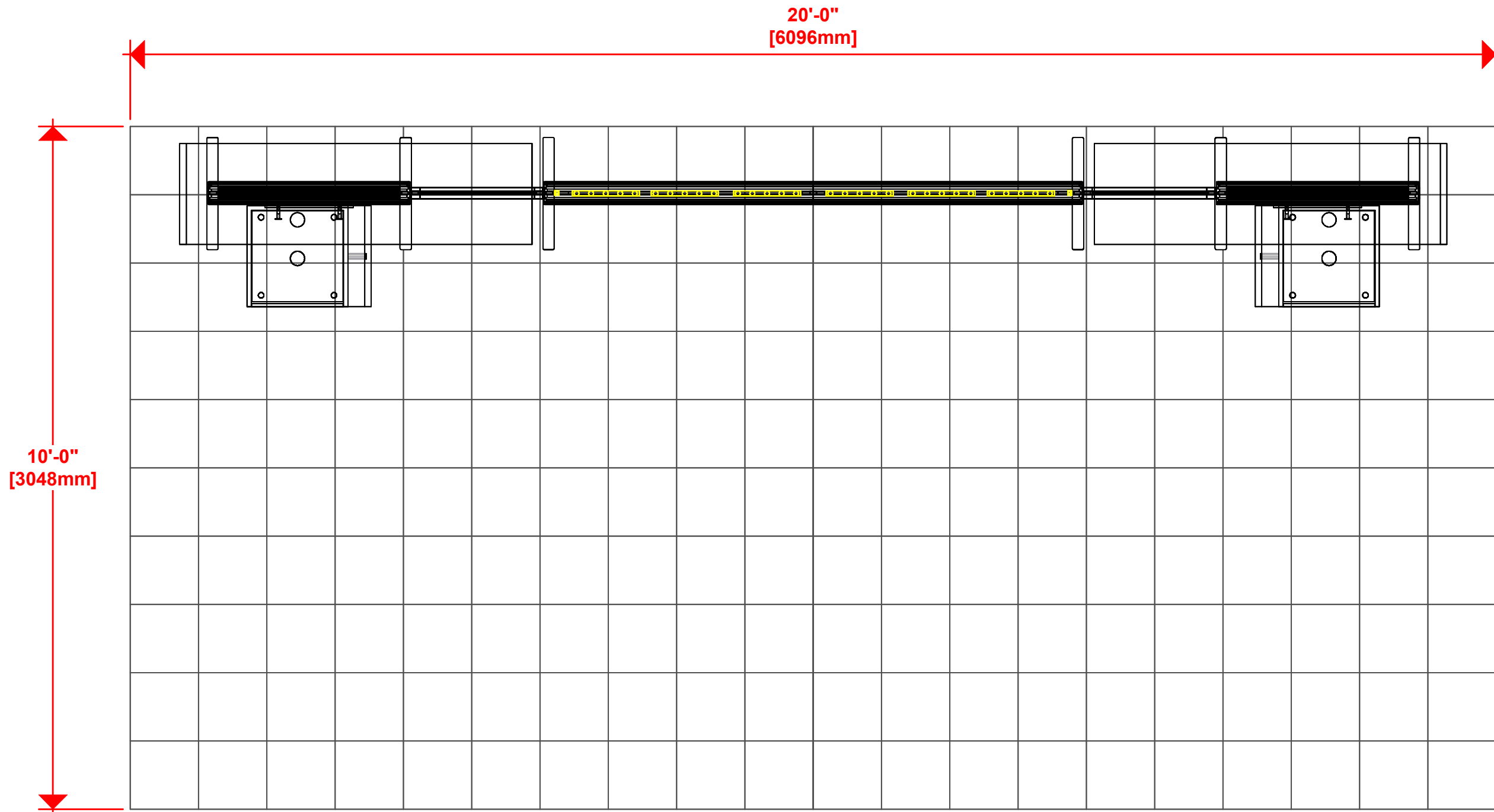

1. Redesign of this exhibit without approval by manufacturer may result in dangerous and unsafe structures. Manufacturer disclaims any responsibility for redesigned exhibits it does not approve in writing.

2. Parts and components such as panels and extrusions are manufactured to metric sizing. Where ever possible sizes have been noted in feet and inches as well as in metric. Below is the imperial to metric sizing table as reference. "Nominal" refers to approximate size.

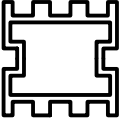
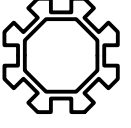
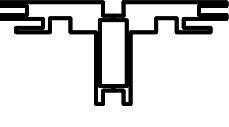
- |                    |                                   |
|--------------------|-----------------------------------|
| 2400mm = (94 1/2") | ☒ Phone Line / Fax                |
| 2100mm = (82 5/8") | ☒ Internet connection             |
| 1800mm = (70 7/8") | ☒ Outlet                          |
| 1500mm = (59")     | ☒ Main Drop (point of distrution) |
| 1200mm = (47 1/4") |                                   |
| 900mm = (35 1/2")  |                                   |
| 600mm = (23 5/8")  |                                   |
| 300mm = (11 7/8")  |                                   |
- Wire running under carpet ---



-  PM2S2
-  PM2R8
-  PHFC4
-  PHFC2
-  PH
-  PH4SC

**(24) LED-WHT-DB-300 LIGHTS = 24W PER STICK**

**HYBRID PRO RENTAL KIT**

Title: SET-UP INSTRUCTIONS

EP

**LED-WHT-DB-300 LIGHTS**

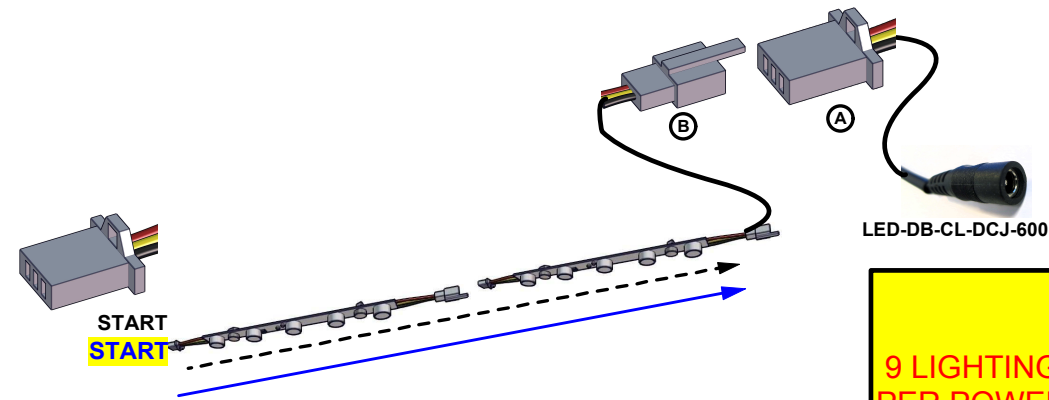
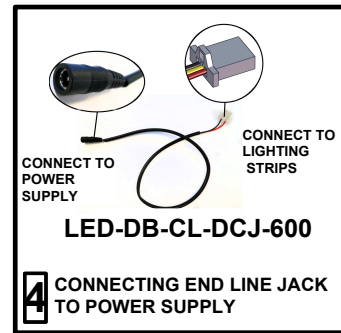
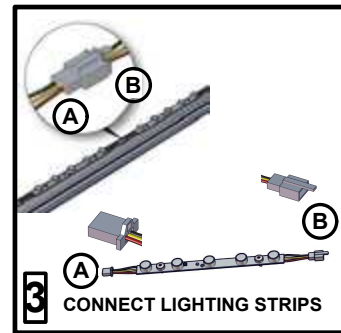
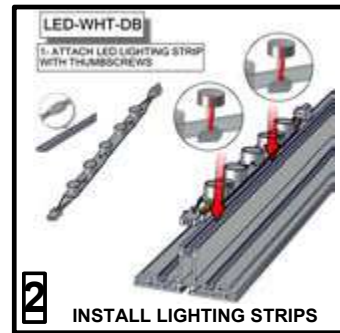
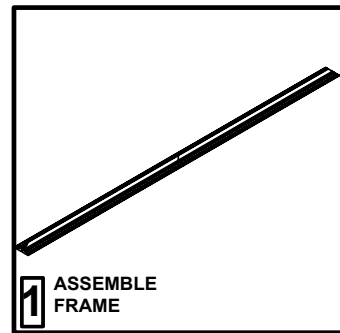

**IMPORTANT!**  
9 LIGHTING STRIPS MAXIMUM  
PER POWER SUPPLY

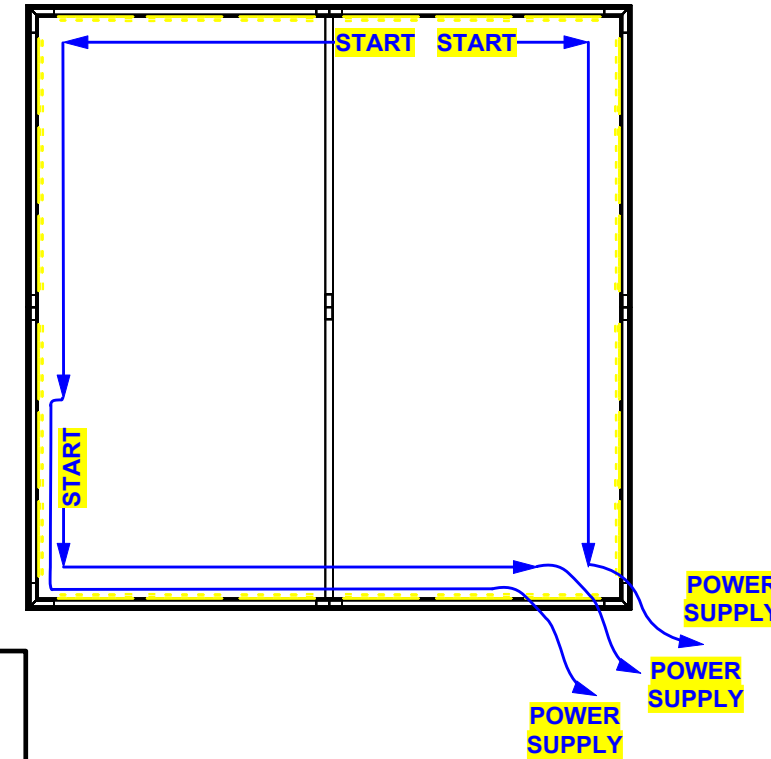

1. Redesign of this exhibit without approval by manufacturer may result in dangerous and unsafe structures. Manufacturer disclaims any responsibility for redesigned exhibits it does not approve in writing.

2. Parts and components such as panels and extrusions are manufactured to metric sizing. Where ever possible sizes have been noted in feet and inches as well as in metric. Below is the imperial to metric sizing table as reference. "Nominal" refers to approximate size.

2400mm = (94 1/2")	Phone Line / Fax
2100mm = (82 5/8")	Internet connection
1800mm = (70 7/8")	Outlet
1500mm = (59")	Main Drop (point of distrution)
1200mm = (47 1/4")	
900mm = (35 1/2")	
600mm = (23 5/8")	
300mm = (11 7/8")	

--- Wire running under carpet

	PM2S2
	PM2R8
	PHFC4
	PHFC2
	PH
	PH4SC

**END LINE CONNECTORS & POWER SUPPLY**

**EXTENSION CORDS**

**HARDWARE**

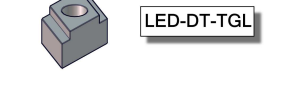
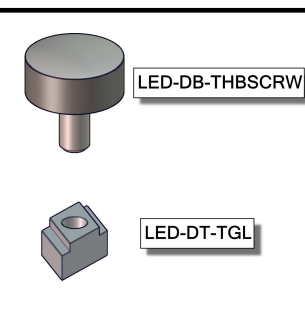
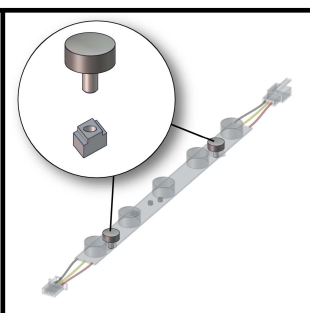
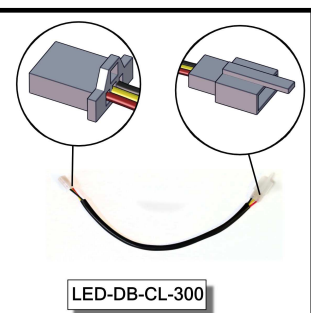
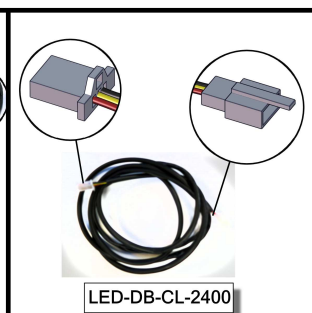
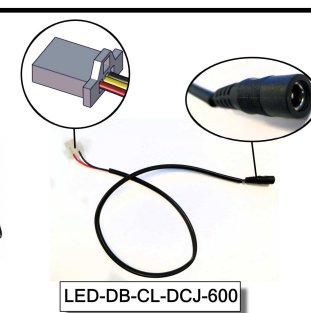

**HYBRID PRO RENTAL KIT**

Title: SET-UP INSTRUCTIONS

Code	#	Description
R10	8	1200MM (47.24") PHFC4 EXTRUSION WITH MITRE CUT 1 END FOR CB9 ONE END-IB2 H
CB9	4	CB9 CORNER BRACKET
IB2	5	INLINE BRACKET CONNECTOR
LED-WHT-DB-300	24	300MM (11.81") LENGTH LED LIGHTS FOR DIRECTIONAL BACKLIGHT
R7	2	1155MM (45.47") PH1 EXTRUSION WITH IB2 HOLE ONE SIDE-WITH LOCK 1 END

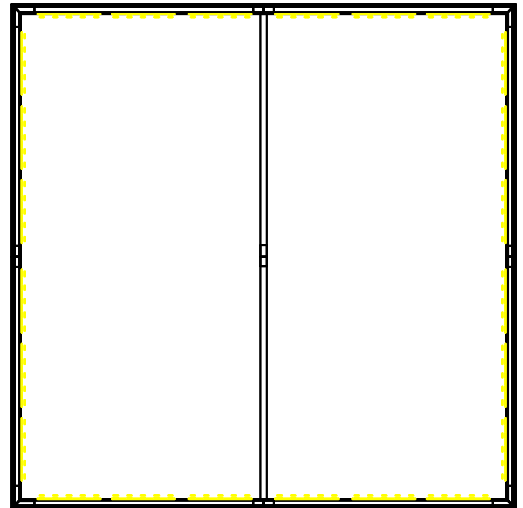
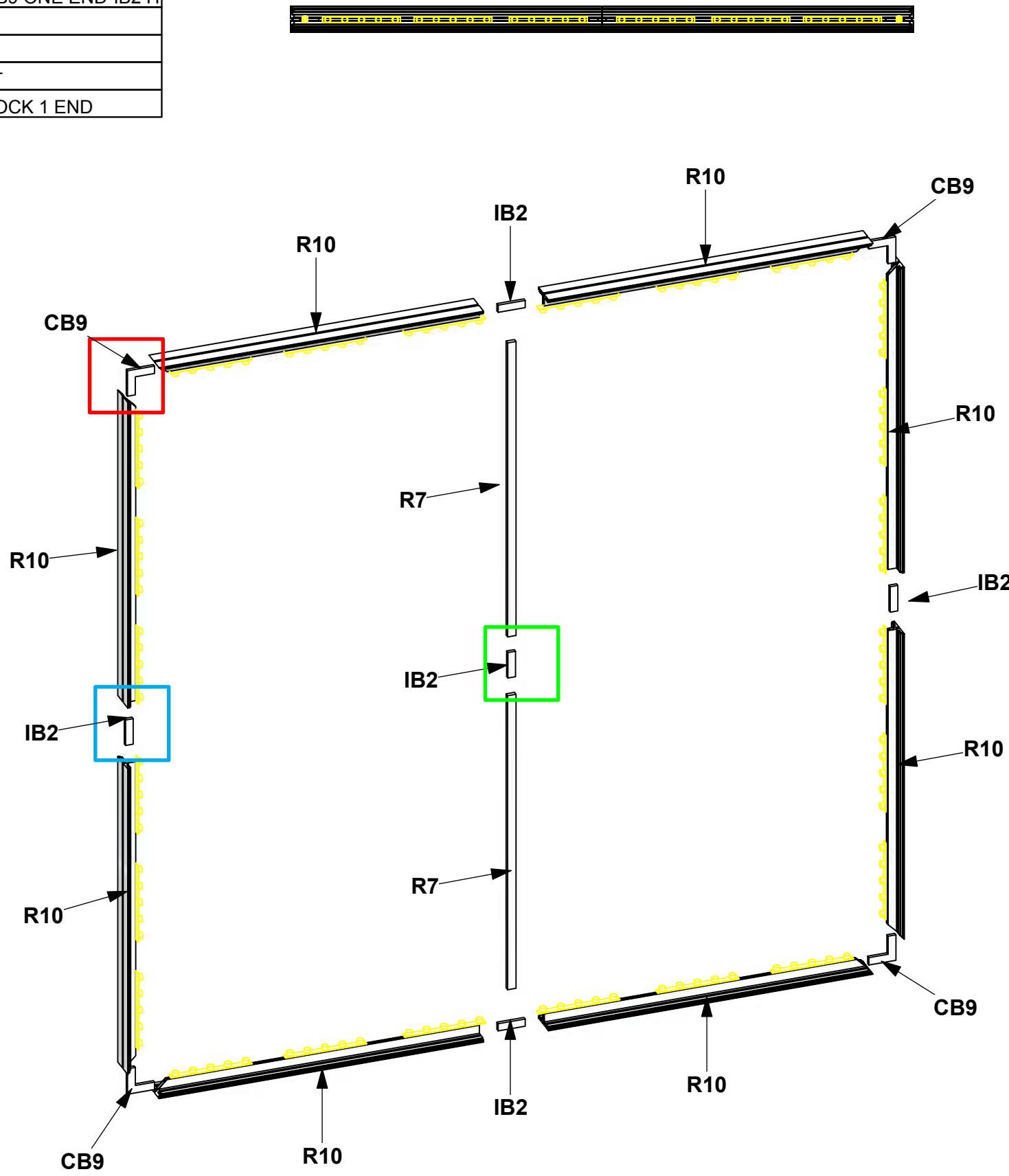
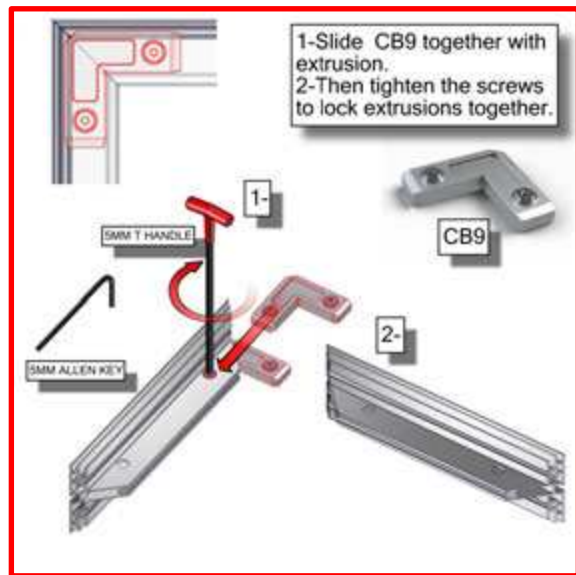

1. Redesign of this exhibit without approval by manufacturer may result in dangerous and unsafe structures. Manufacturer disclaims any responsibility for redesigned exhibits it does not approve in writing.

2. Parts and components such as panels and extrusions are manufactured to metric sizing. Where ever possible sizes have been noted in feet and inches as well as in metric. Below is the imperial to metric sizing table as reference. "Nominal" refers to approximate size.

2400mm = (94 1/2")	Phone Line / Fax
2100mm = (82 5/8")	Internet connection
1800mm = (70 7/8")	Outlet
1500mm = (59")	Main Drop (point of distrution)
1200mm = (47 1/4")	
900mm = (35 1/2")	
600mm = (23 5/8")	
300mm = (11 7/8")	

--- Wire running under carpet

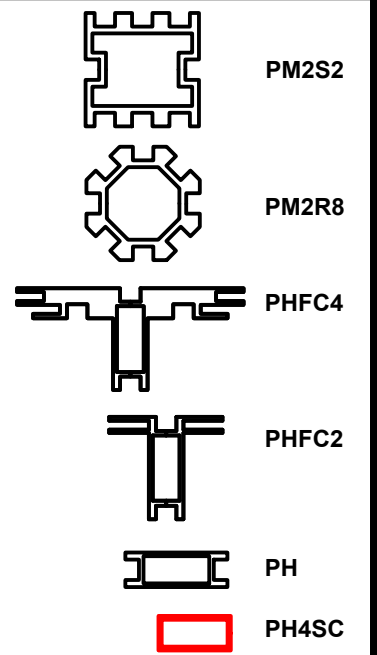

**HYBRID PRO RENTAL KIT**

Title: SET-UP INSTRUCTIONS

Code	#	Description
SW-FOOT	2	SMARTWALL SUPPORT FOOT
GRAPHIC C	1	94 1/2" (H) X 94 1/2" (W) BACKLIT DYESUB GRAPHIC W/ FCE-2 (SEG) ON PERIM
UNPRINTED C	1	94 1/2" (H) X 94 1/2" (W) WHITE FABRIC W/ FCE-2 (SEG) ON PERIMETER
LN-100	2	JOINING BAR

1. Redesign of this exhibit without approval by manufacturer may result in dangerous and unsafe structures. Manufacturer disclaims any responsibility for redesigned exhibits it does not approve in writing.

2. Parts and components such as panels and extrusions are manufactured to metric sizing. Where ever possible sizes have been noted in feet and inches as well as in metric. Below is the imperial to metric sizing table as reference. "Nominal" refers to approximate size.

2400mm = (94 1/2")	Phone Line / Fax
2100mm = (82 5/8")	Internet connection
1800mm = (70 7/8")	Outlet
1500mm = (59")	Main Drop (point of distrution)
1200mm = (47 1/4")	
900mm = (35 1/2")	
600mm = (23 5/8")	
300mm = (11 7/8")	

--- Wire running under carpet

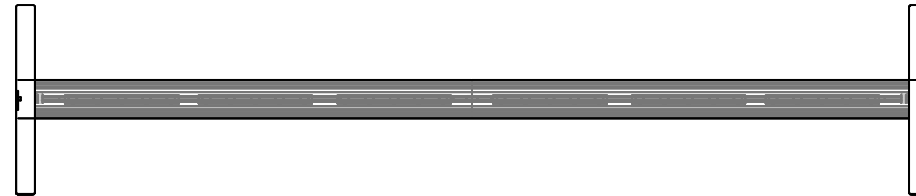

FCE-2 TO PHFC4

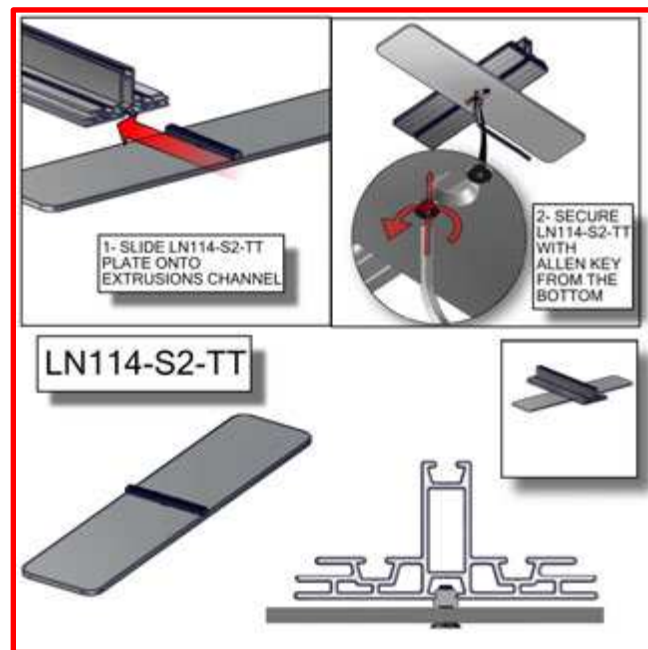
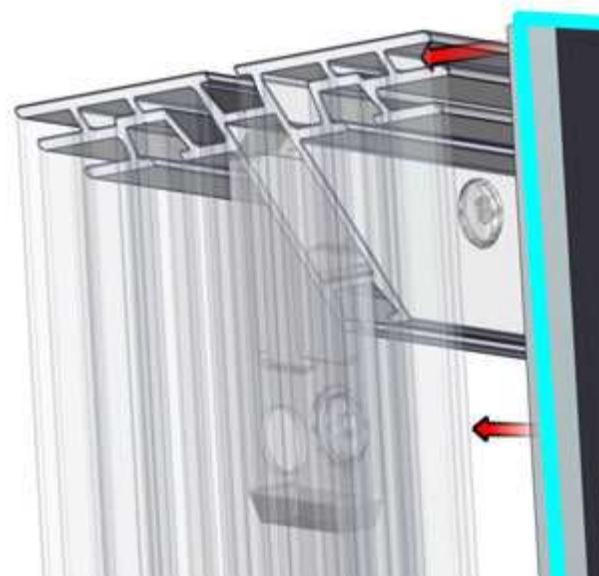

FCE-2 TO PHFC4

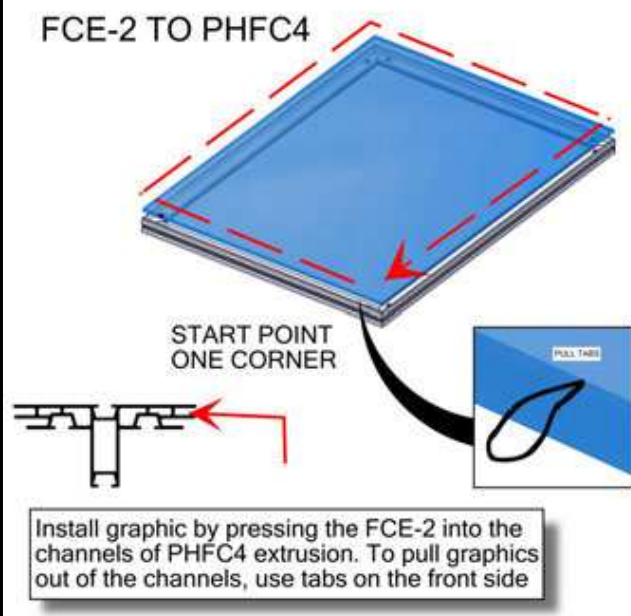

FCE-2 TO PHFC4

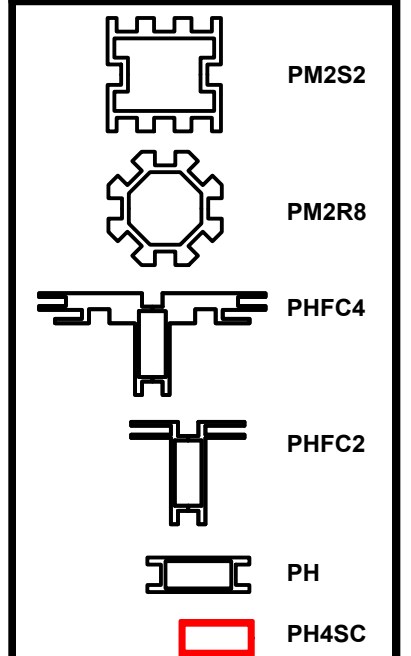
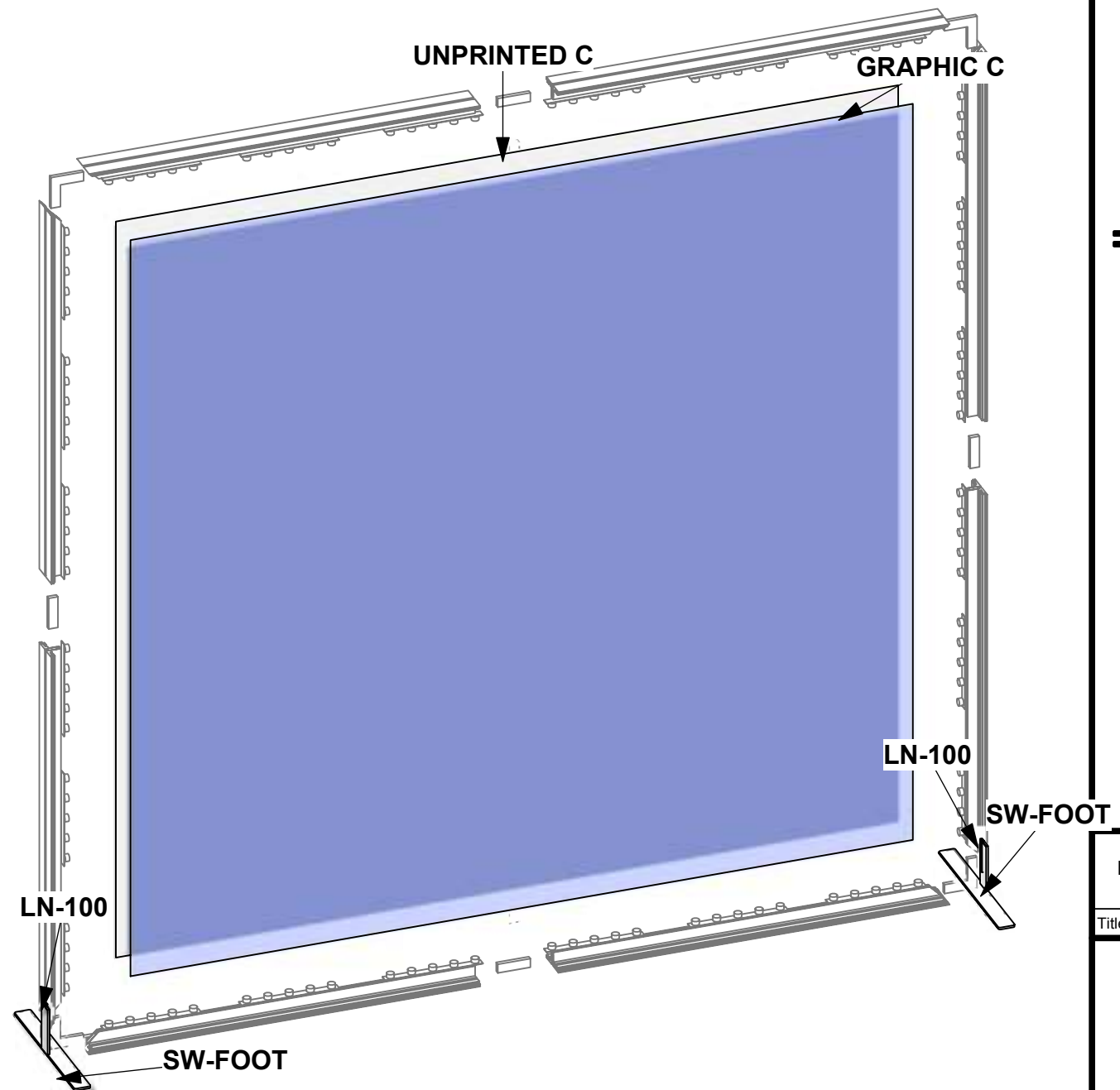
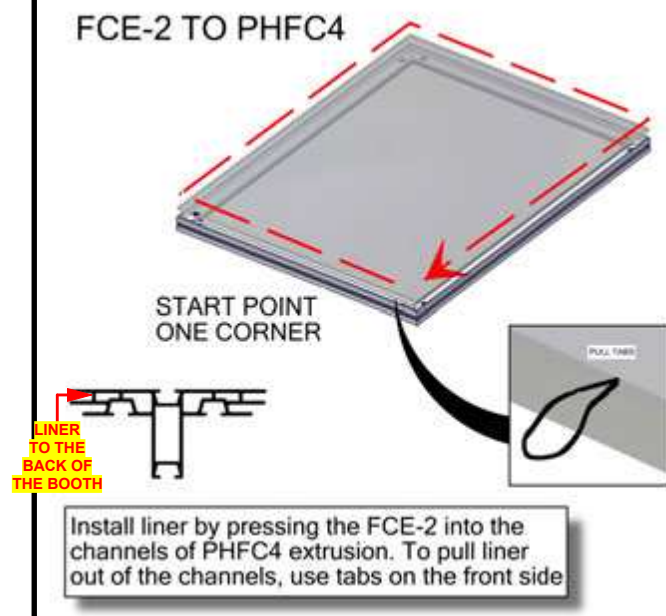

**HYBRID PRO RENTAL KIT**

Title: SET-UP INSTRUCTIONS

Code	#	Description
R55	4	510MM (20.08") PHFC2 EXTRUSION WITH LOCKS 2 ENDS
IB2	4	INLINE BRACKET CONNECTOR
CB9-S	8	50MM SQUARE PHCF2 CORNER BRACKET
R43	6	855MM (33.66") PHFC2 EXTRUSION WITH LOCKS 2 ENDS WITH

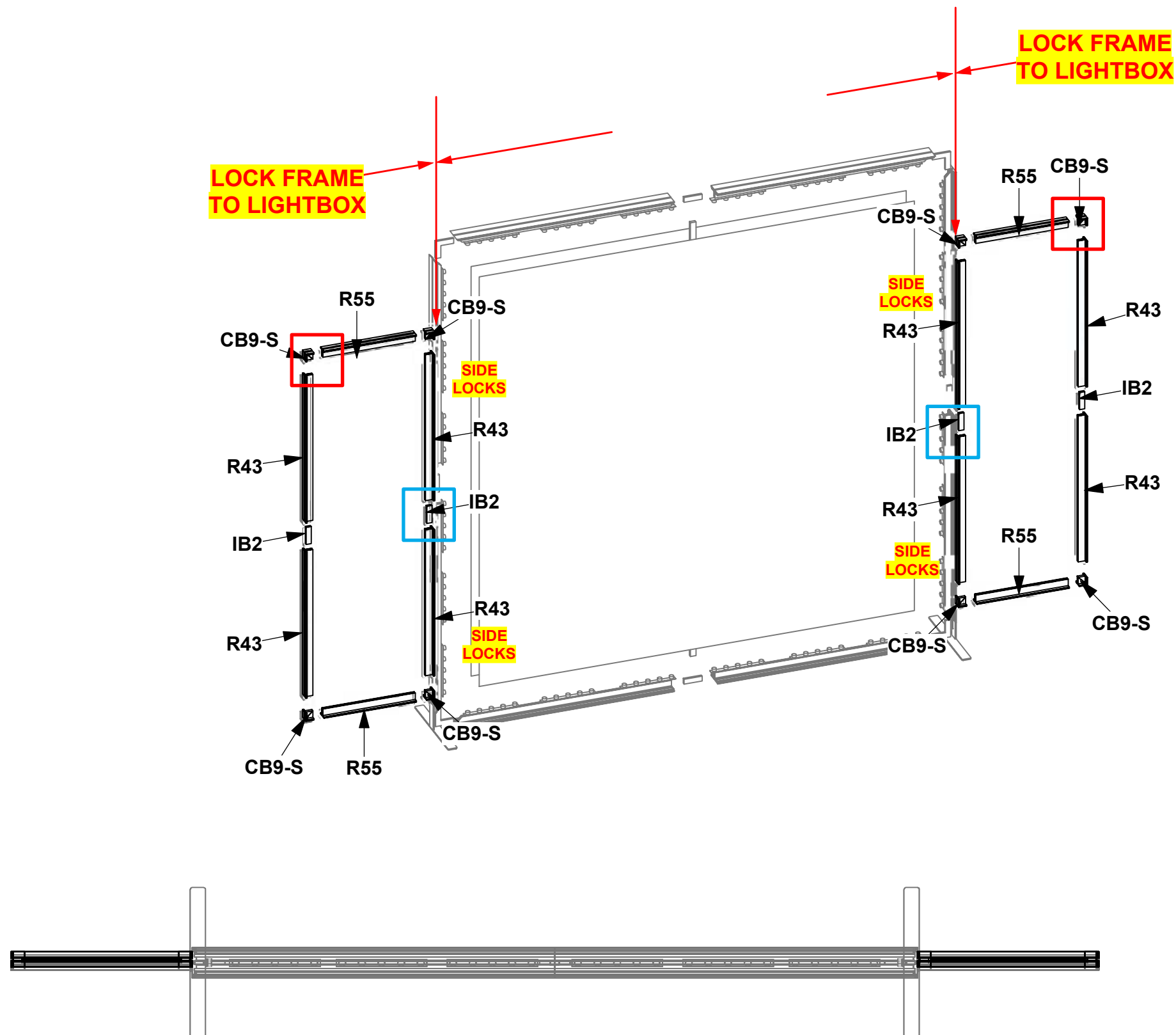
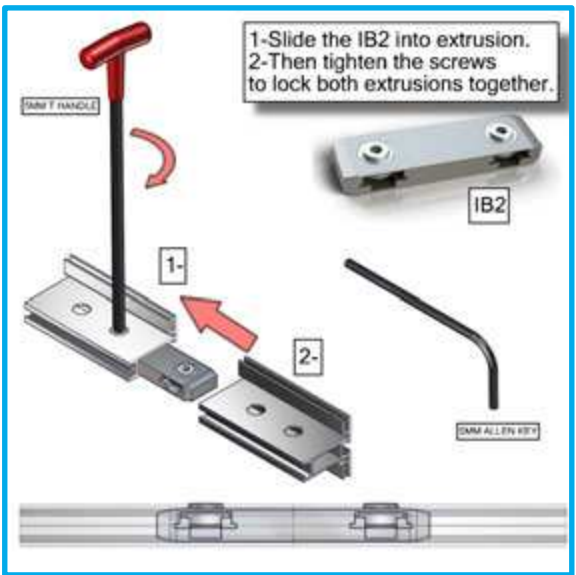
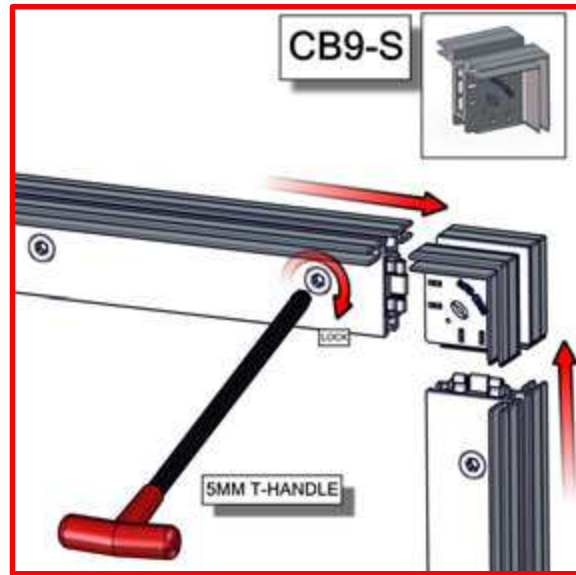

1. Redesign of this exhibit without approval by manufacturer may result in dangerous and unsafe structures. Manufacturer disclaims any responsibility for redesigned exhibits it does not approve in writing.

2. Parts and components such as panels and extrusions are manufactured to metric sizing. Where ever possible sizes have been noted in feet and inches as well as in metric. Below is the imperial to metric sizing table as reference. "Nominal" refers to approximate size.

2400mm = (94 1/2")	Phone Line / Fax
2100mm = (82 5/8")	Internet connection
1800mm = (70 7/8")	Outlet
1500mm = (59")	Main Drop (point of distrution)
1200mm = (47 1/4")	
900mm = (35 1/2")	
600mm = (23 5/8")	
300mm = (11 7/8")	

--- Wire running under carpet

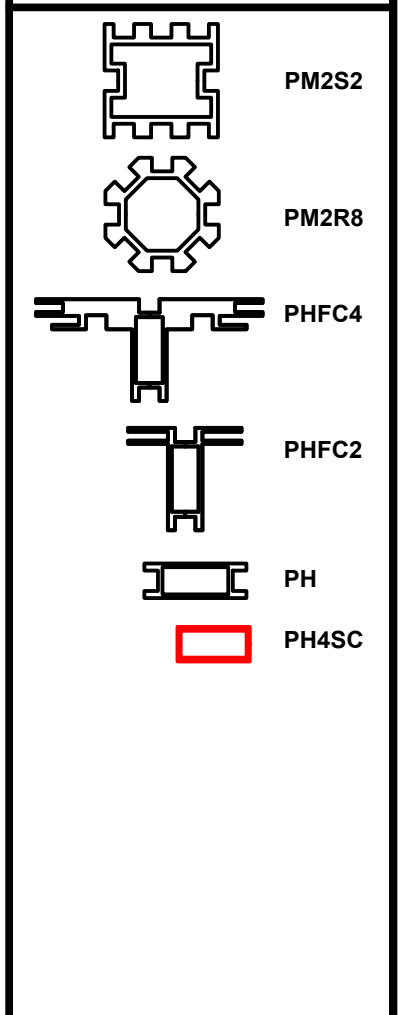

**HYBRID PRO RENTAL KIT**

Title: SET-UP INSTRUCTIONS



Code	#	Description
SW-FOOT	4	SMARTWALL SUPPORT FOOT
R10	4	1200MM (47.24") PHFC4 EXTRUSION WITH MITRE CUT 1 END FOR CB9 ONE END-IB2 HOLE
R41	4	900MM (35.43") PHFC4 EXTRUSION WITH MITRE CUT 1 END FOR CB9 ONE END-IB2 HOLES
CB9	8	CB9 CORNER BRACKET
R26	4	900MM (35.43") PHFC4 EXTRUSION WITH MITRE CUT BOTH ENDS
IB2	4	INLINE BRACKET CONNECTOR
R42	4	810MM (31.89") 50MM PM2S 4 WAY SQUARE EXTRUSION WITH LOCKS 2 ENDS
LN-100	4	JOINING BAR

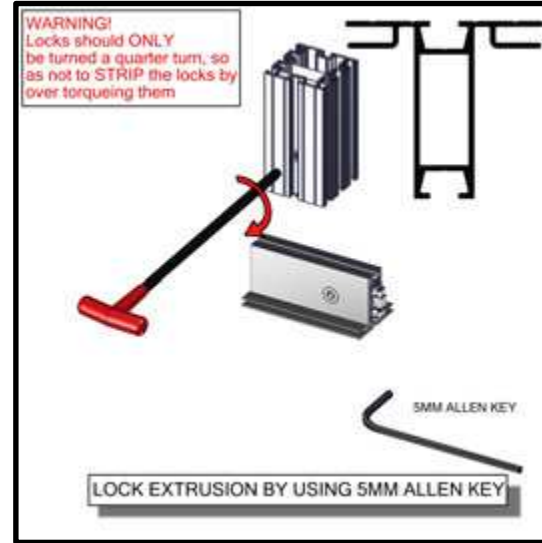

1. Redesign of this exhibit without approval by manufacturer may result in dangerous and unsafe structures. Manufacturer disclaims any responsibility for redesigned exhibits it does not approve in writing.

2. Parts and components such as panels and extrusions are manufactured to metric sizing. Where ever possible sizes have been noted in feet and inches as well as in metric. Below is the imperial to metric sizing table as reference. "Nominal" refers to approximate size.

2400mm = (94 1/2")	Phone Line / Fax
2100mm = (82 5/8")	Internet connection
1800mm = (70 7/8")	Outlet
1500mm = (59")	Main Drop (point of distrution)
1200mm = (47 1/4")	
900mm = (35 1/2")	
600mm = (23 5/8")	
300mm = (11 7/8")	

--- Wire running under carpet

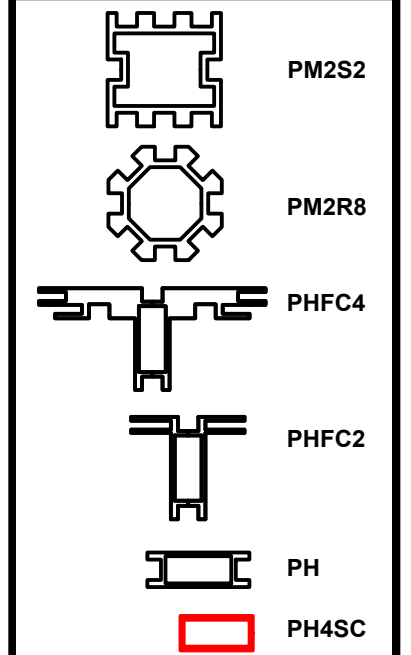
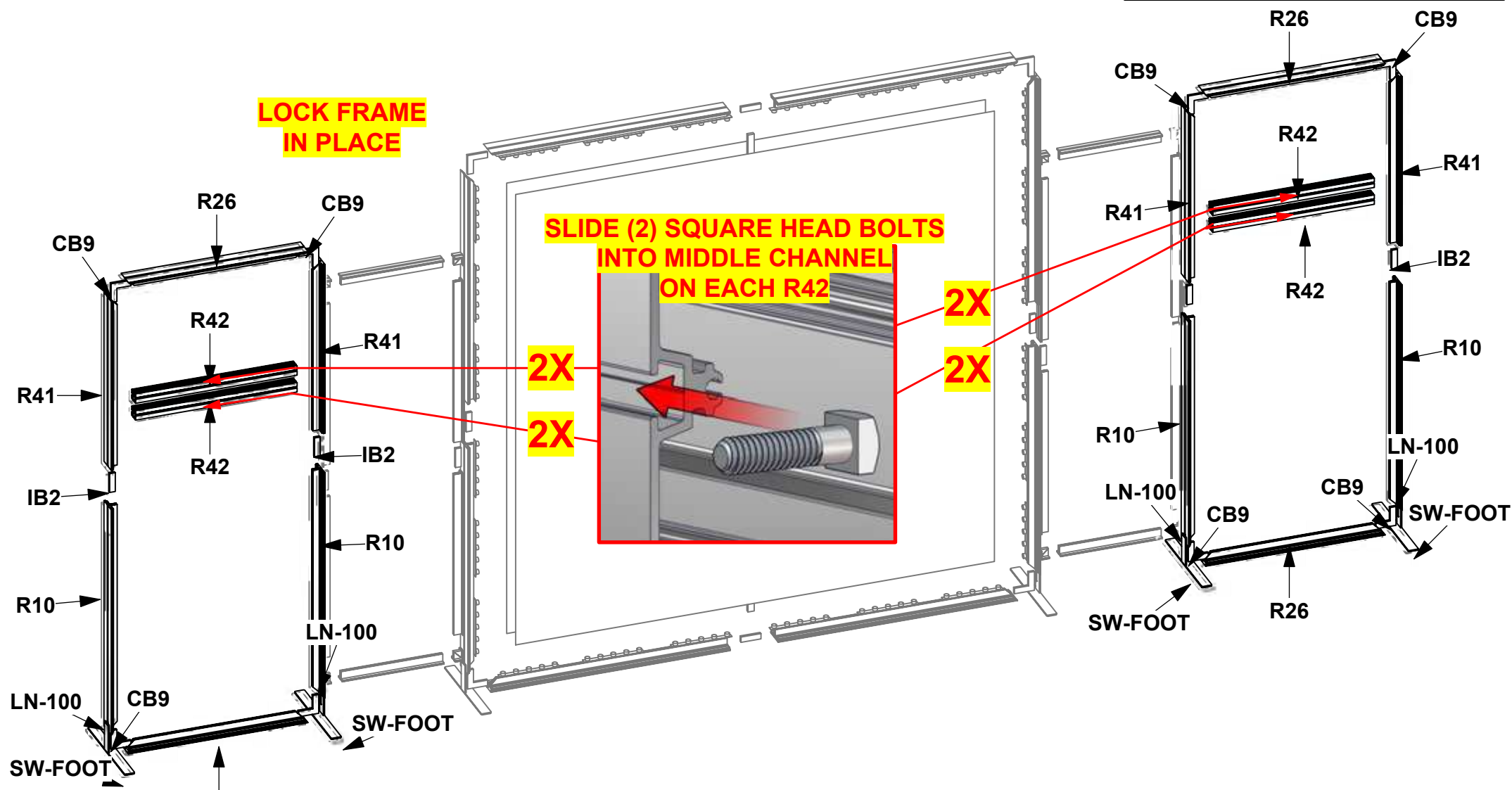
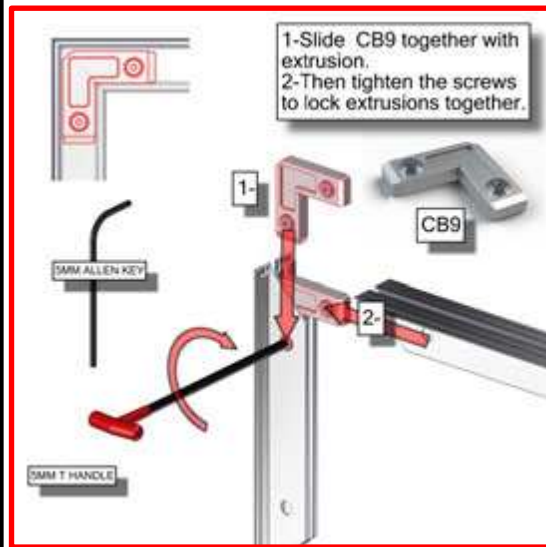

HYBRID PRO RENTAL KIT

Title: SET-UP INSTRUCTIONS

Code	#	Description
GRAPHIC B2	1	70 7/8" (H) X 23 5/8" (W) SINGLE SIDED DYESUB GRAPHIC W/ FCE-2 (SEG) O
GRAPHIC A1	1	82 11/16" (H) X 35 7/16" (W) SINGLE SIDED DYESUB GRAPHIC W/ FCE-2 (SE
MM-MB	2	MEDIUM MONITOR BRACKET FOR MONITORS 15"-40"
GRAPHIC A2	1	82 11/16" (H) X 35 7/16" (W) SINGLE SIDED DYESUB GRAPHIC W/ FCE-2 (SE

1. Redesign of this exhibit without approval by manufacturer may result in dangerous and unsafe structures. Manufacturer disclaims any responsibility for redesigned exhibits it does not approve in writing.

2. Parts and components such as panels and extrusions are manufactured to metric sizing. Where ever possible sizes have been noted in feet and inches as well as in metric. Below is the imperial to metric sizing table as reference. "Nominal" refers to approximate size.

2400mm = (94 1/2")	Phone Line / Fax
2100mm = (82 5/8")	Internet connection
1800mm = (70 7/8")	Outlet
1500mm = (59")	Main Drop (point of distrution)
1200mm = (47 1/4")	
900mm = (35 1/2")	
600mm = (23 5/8")	
300mm = (11 7/8")	

--- Wire running under carpet

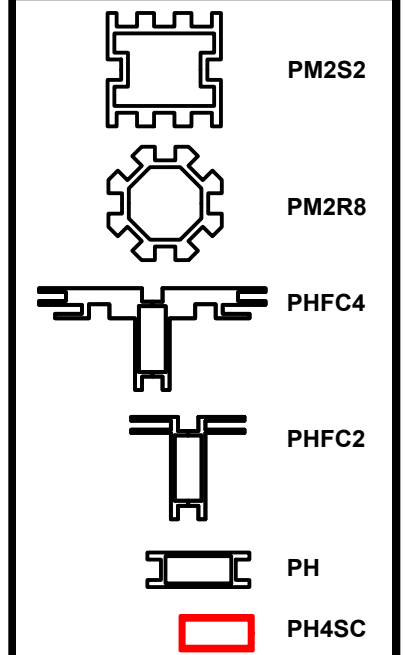
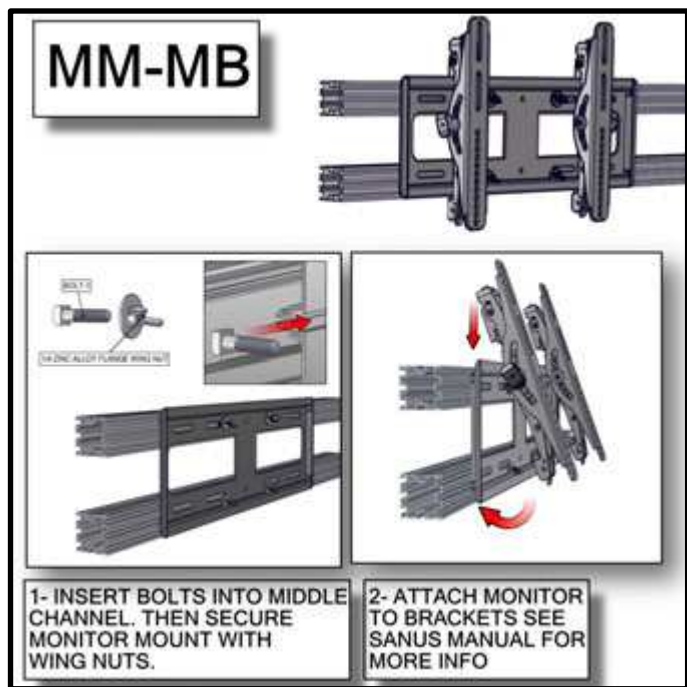
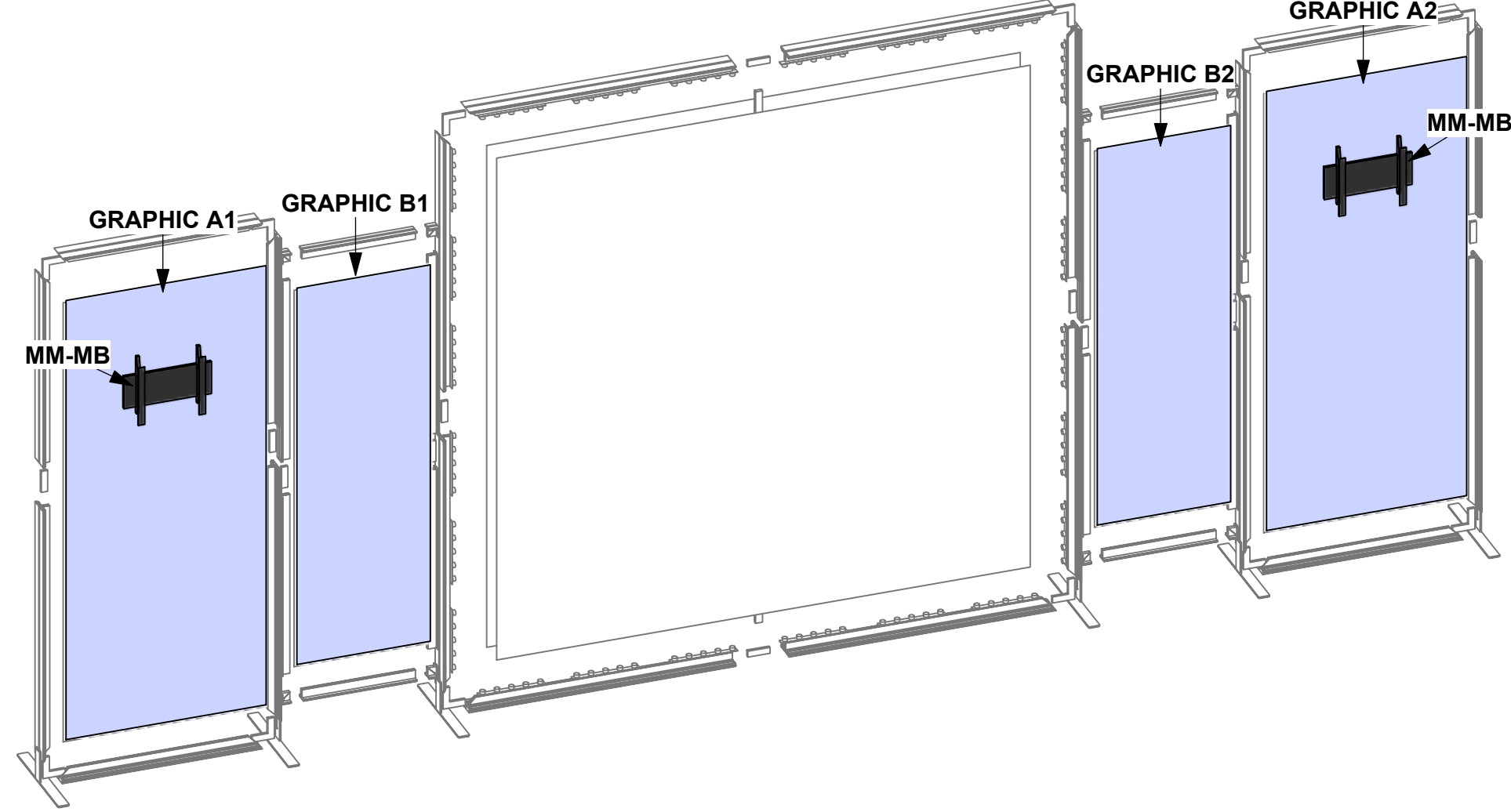
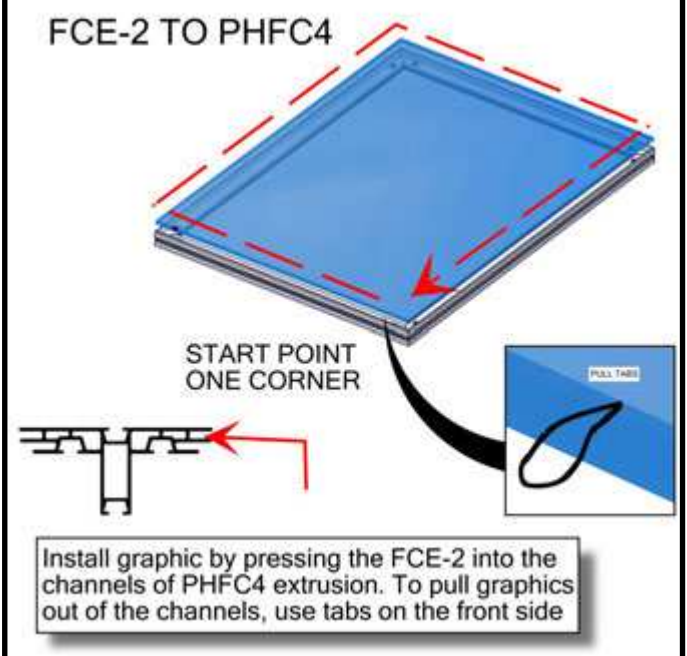

**HYBRID PRO RENTAL KIT**

Title: SET-UP INSTRUCTIONS

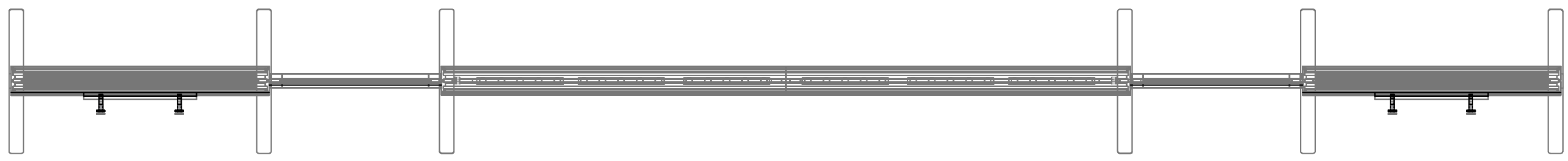

**SET UP INSTRUCTIONS:**

1. CONNECT BOTTOM AND TOP RAILS FOLLOWING THE LABELS
2. CONNECT SIDE RAILS
3. CLEAN THE FRAME AND PLACE THEM ON CLEAN PLACE
4. CAREFULLY REMOVE FABRIC COVER FROM BAGS
5. PLACE COVER AROUND THE BOTTOM OF THE FRAME
6. PULL COVER CAREFULLY UP TO THE TOP
7. CLOSE ALL ZIPPERS
8. ADJUST FABRIC AROUND THE FRAME

**BREAK DOWN INSTRUCTIONS:**

REVERSE SET-UP STEPS TO BREAKDOWN FRAME

**FABRIC CARE INSTRUCTIONS:**

1. UNZIP COVER ZIPPERS
2. CAREFULLY REMOVE FABRIC COVER
3. CLOSE ALL ZIPPERS
4. FOLD OR ROLL NEATLY
5. PLACE FABRIC IN COVER BAG

**PART LIST:**

- PER UNIT
- 14 30MM DIA. TUBE SECTIONS
  - 1 FABRIC COVER

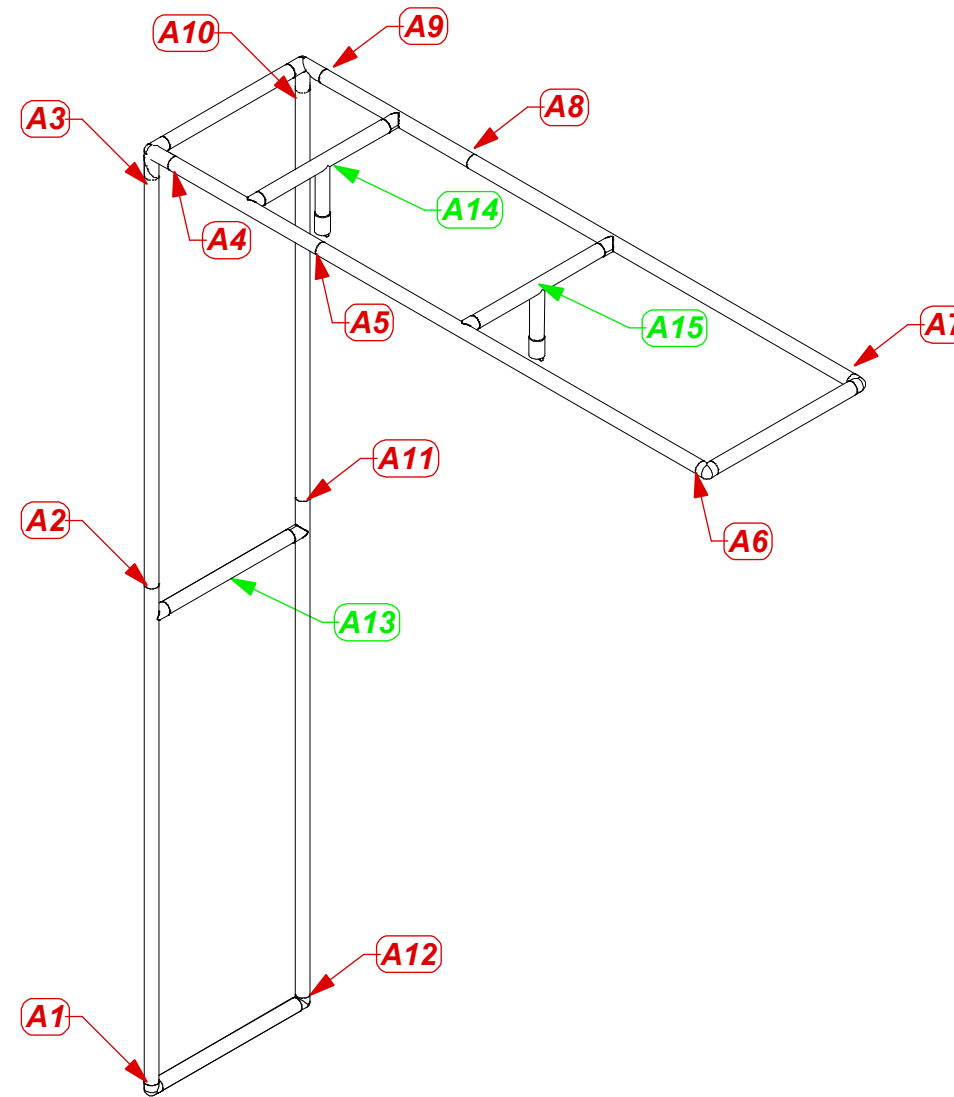
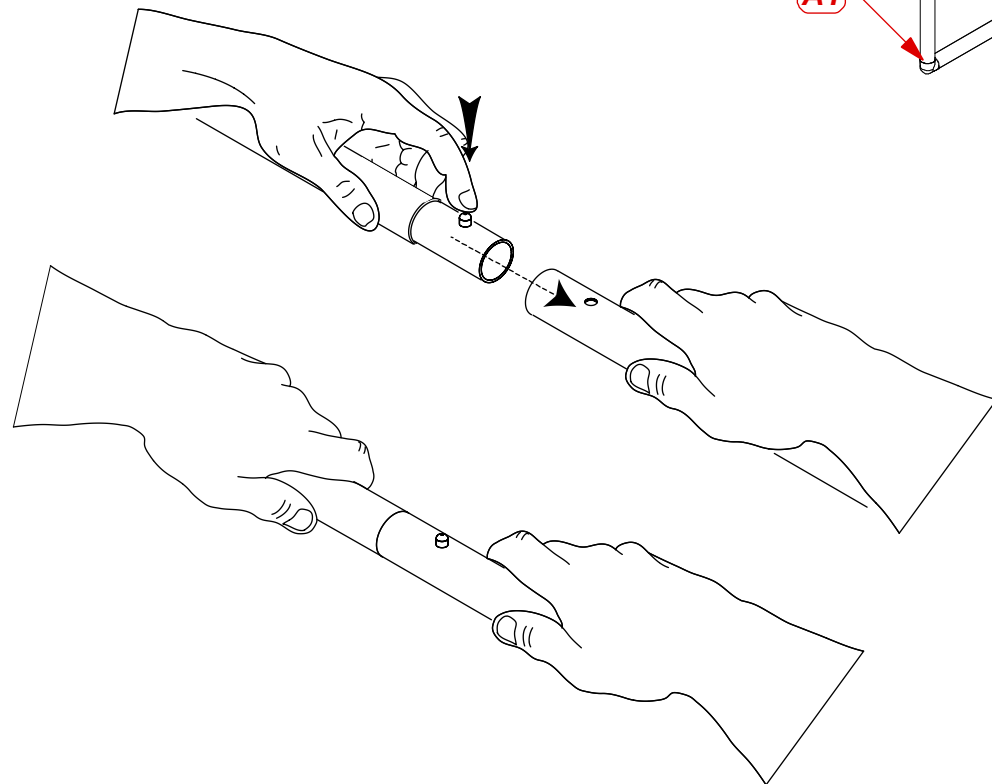

**Frame 'A' Assembly**

Assemble frame as shown

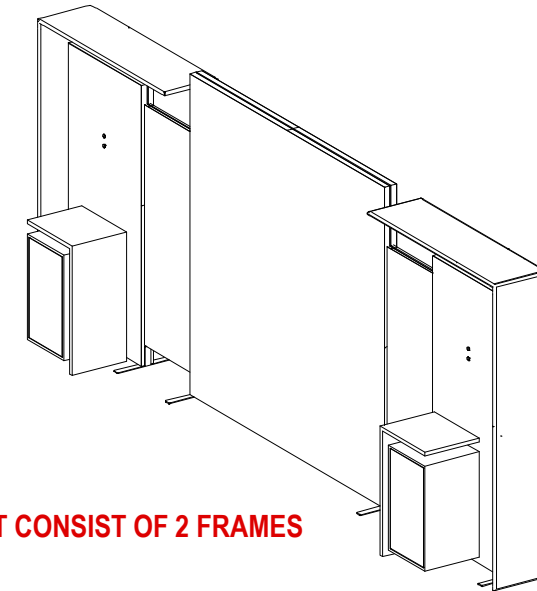

ZIPPER ON INSIDE OF THE FRAME

ZIPPERS

GRAPHIC PILLOWCASE

1. Redesign of this exhibit without approval by manufacturer may result in dangerous and unsafe structures. Manufacturer disclaims any responsibility for redesigned exhibits it does not approve in writing.

2. Parts and components such as panels and extrusions are manufactured to metric sizing. Where ever possible sizes have been noted in feet and inches as well as in metric. Below is the imperial to metric sizing table as reference. "Nominal" refers to approximate size.

2400mm = (94 1/2")	Phone Line / Fax
2100mm = (82 5/8")	Internet connection
1800mm = (70 7/8")	Outlet
1500mm = (59")	Main Drop (point of distrution)
1200mm = (47 1/4")	
900mm = (35 1/2")	
600mm = (23 5/8")	
300mm = (11 7/8")	

Wire running under carpet

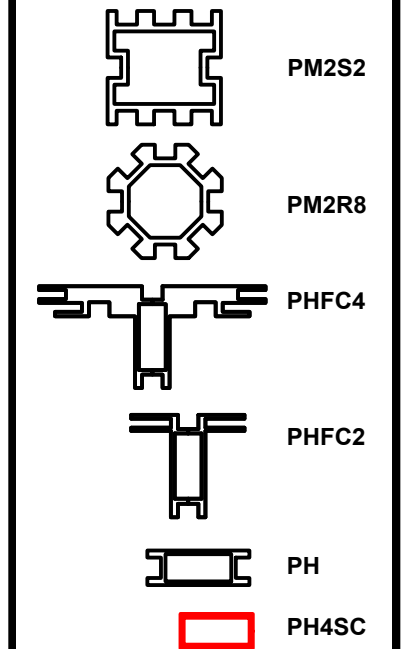

HYBRID PRO RENTAL KIT

Title: SET-UP INSTRUCTIONS

Code	#	Description
CUST FS	2	APPROX. 62" W X 90" H X 18" D CUSTOM L-SHAPED FABRIC STRUCTURE



1. Redesign of this exhibit without approval by manufacturer may result in dangerous and unsafe structures. Manufacturer disclaims any responsibility for redesigned exhibits it does not approve in writing.

2. Parts and components such as panels and extrusions are manufactured to metric sizing. Where ever possible sizes have been noted in feet and inches as well as in metric. Below is the imperial to metric sizing table as reference. "Nominal" refers to approximate size.

2400mm = (94 1/2")	☒ Phone Line / Fax
2100mm = (82 5/8")	☒ Internet connection
1800mm = (70 7/8")	☒ Outlet
1500mm = (59")	☒ Main Drop (point of distrution)
1200mm = (47 1/4")	
900mm = (35 1/2")	
600mm = (23 5/8")	
300mm = (11 7/8")	

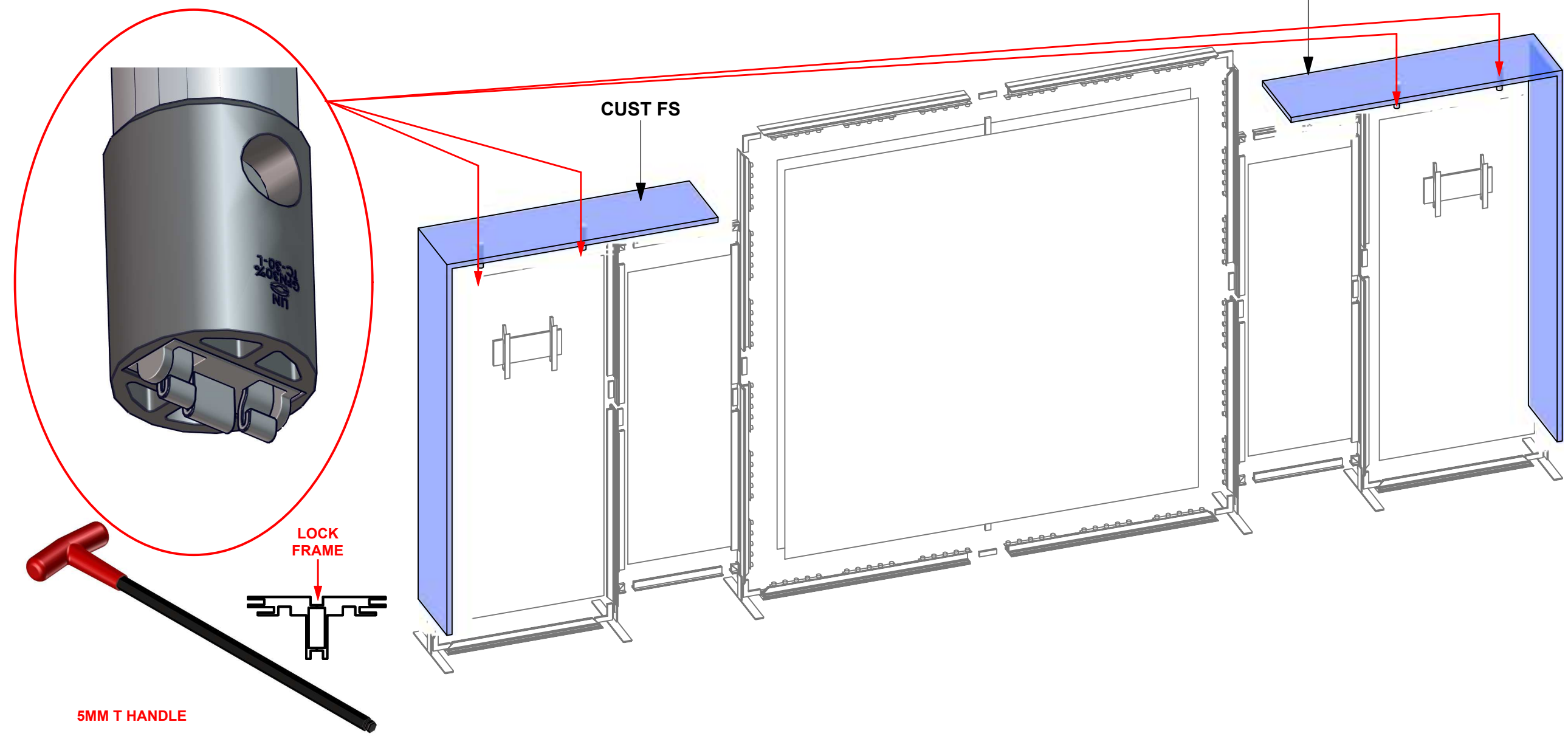
--- Wire running under carpet

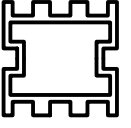
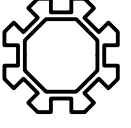
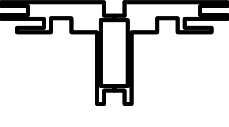
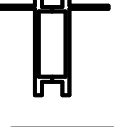

-  PM2S2
-  PM2R8
-  PHFC4
-  PHFC2
-  PH
-  PH4SC

**HYBRID PRO RENTAL KIT**

Title: SET-UP INSTRUCTIONS

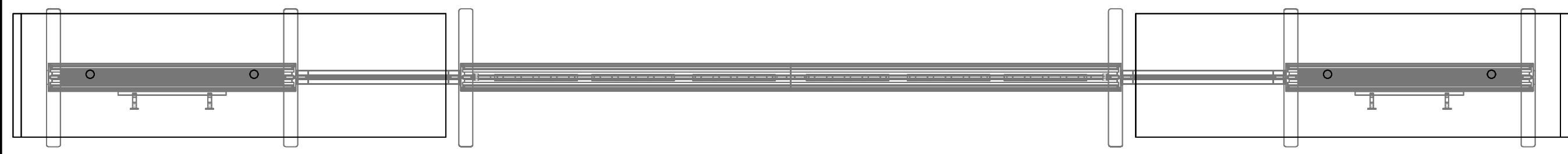

# **PACKING INSTRUCTIONS**

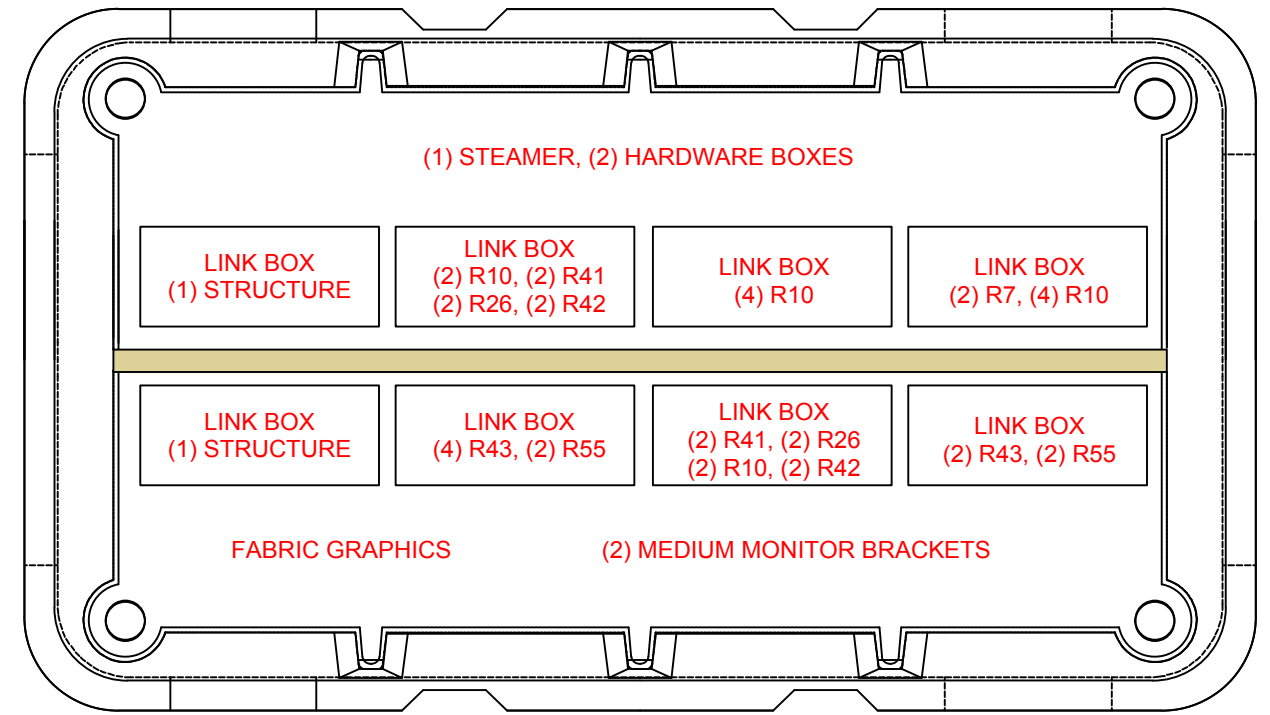

# CASE # 1

<b>LEGEND</b>		GREY FOAM FOLDED TO FILL EMPTY SPACES OR USED AS PROTECTION
		1/8" CARDBOARD SPACER (PUT IN BETWEEN EVERY PANEL)
		DIVIDER
		1/4" WHITE FOAM (USED AS PROTECTION DOOR PANELS W/ LOCKS)



**R-HPC-01-B**

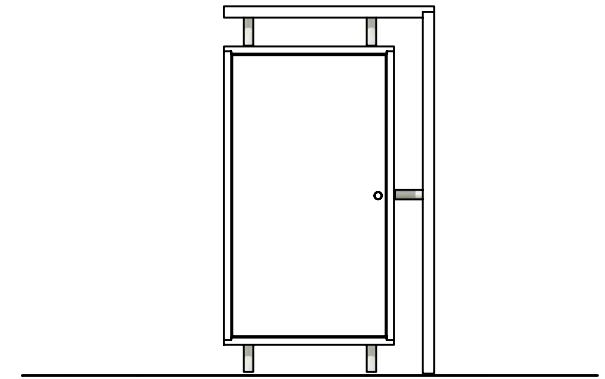
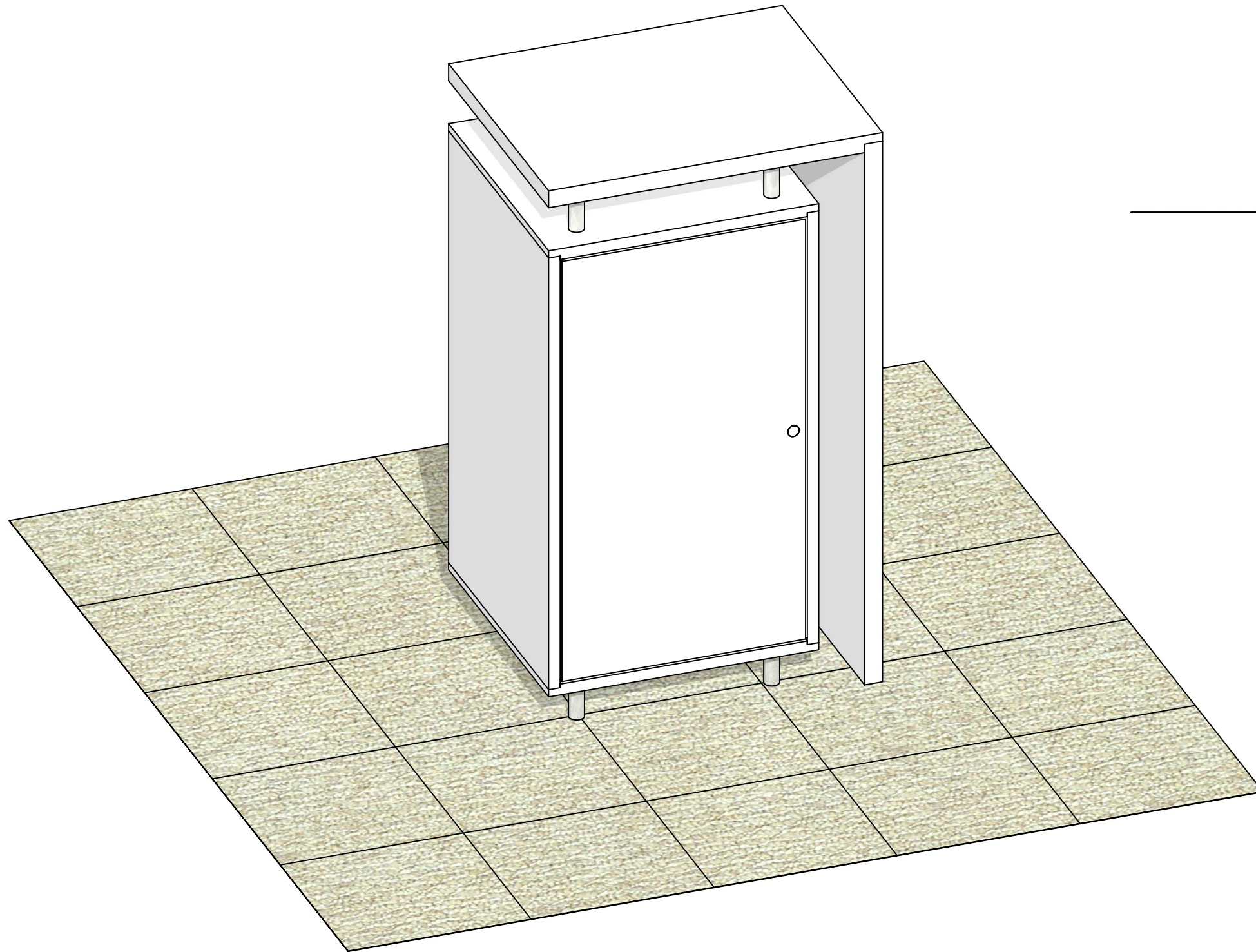

Code	#	Description
R-HPC-01-B-CT	2	4' X 2' X 2' L-SHAPED COUNTER TOP FOR R-HPC-01-A UNIT
SS4	8	SILVER SS4 SHELF SUPPORTS
SO-1 1/4 X 3	18	1 1/4" X 3" L STANDOFF ASSEMBLY
R-HPC-01-B-CAB	2	4' X 2" X 2' CUSTOM CABINET WITH SINGLE DOOR ON BACK (HIDDEN HINGES), INTERNAL SHELF AND WIRE M
R-HPC-01-A-INT	2	2' X 2' X 5/8" INTERNAL SHELF FOR HPC-01-B

# BOM

R-HPC-01-B

(2) UNITS

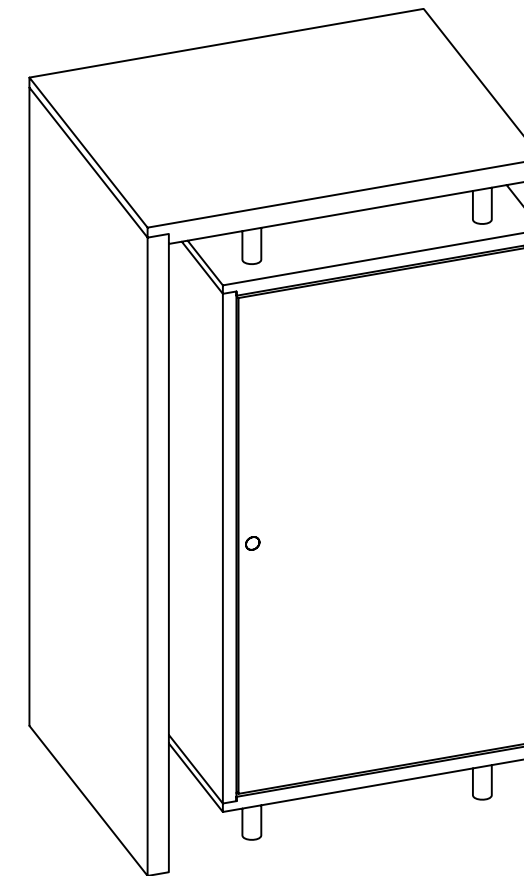
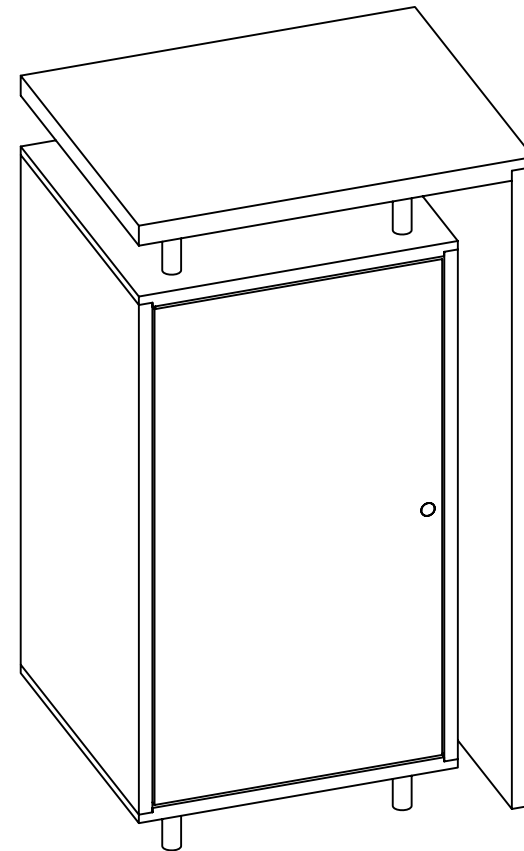
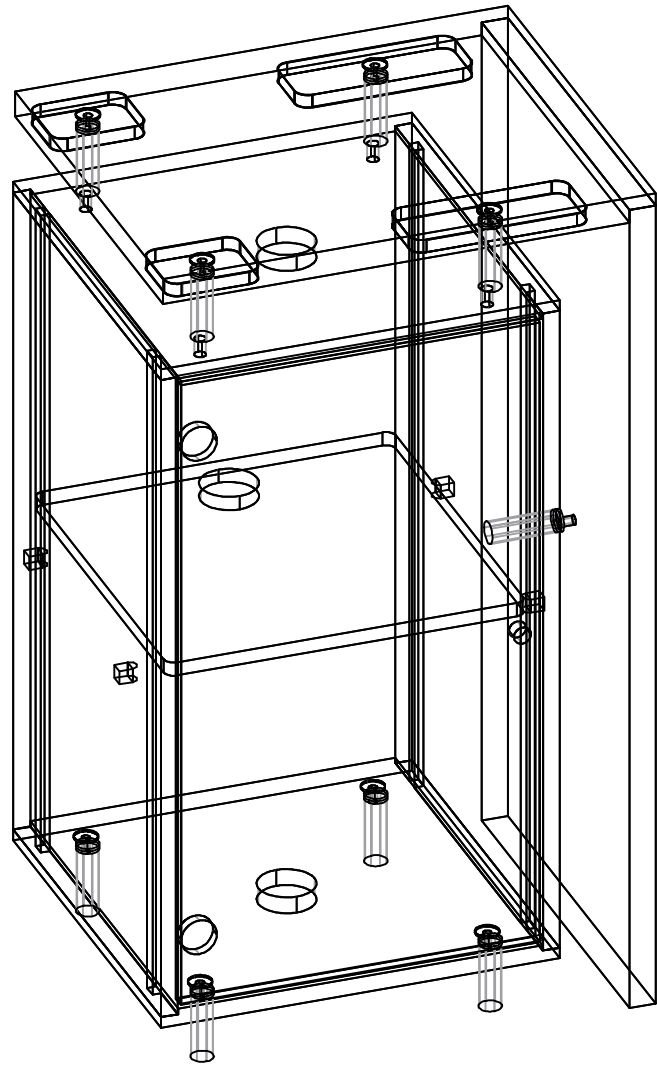
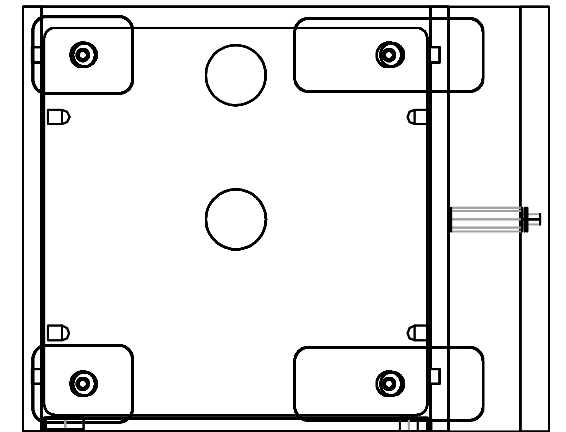



1. Redesign of this exhibit without approval by manufacturer may result in dangerous and unsafe structures. Manufacturer disclaims any responsibility for redesigned exhibits it does not approve in writing.

2. Parts and components such as panels and extrusions are manufactured to metric sizing. Where ever possible sizes have been noted in feet and inches as well as in metric. Below is the imperial to metric sizing table as reference. "Nominal" refers to approximate size.

2400mm = (94 1/2")	☒ Phone Line / Fax
2100mm = (82 5/8")	☒ Internet connection
1800mm = (70 7/8")	☒ Outlet
1500mm = (59")	☒ Main Drop (point of distrution)
1200mm = (47 1/4")	
900mm = (35 1/2")	
600mm = (23 5/8")	
300mm = (11 7/8")	

--- Wire running under carpet

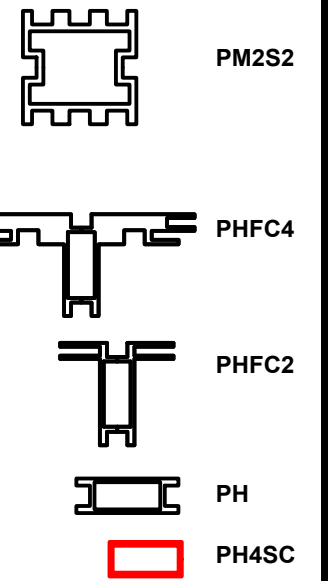
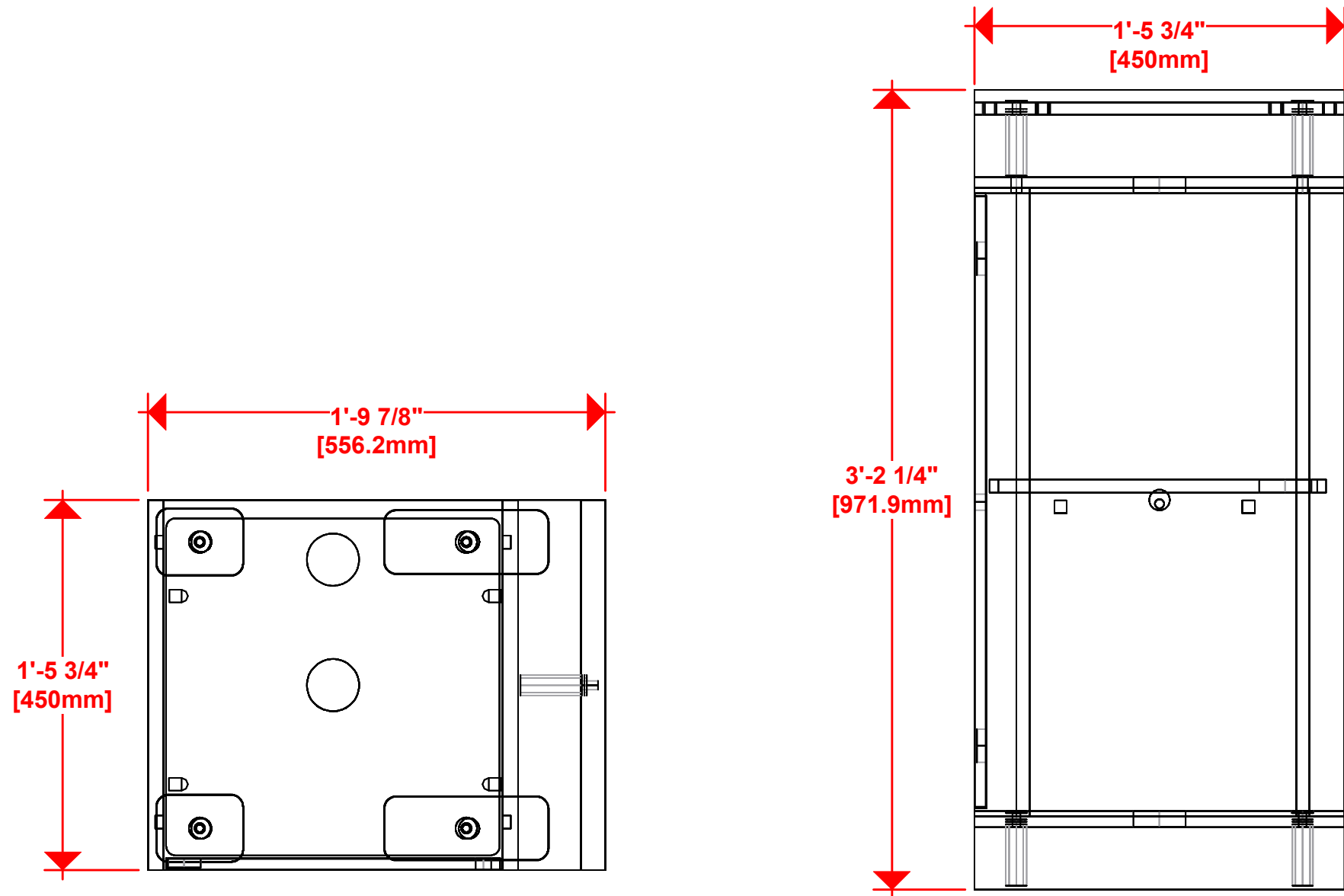

**HYBRID PRO RENTAL KIT**

Title: SET-UP INSTRUCTIONS

Code	#	Description
SO-1 1/4 X 3	9	1 1/4" X 3" L STANDOFF ASSEMBLY
R-HPC-01-B-C	1	4' X 2" X 2' CUSTOM CABINET WITH SINGLE DOOR ON BACK (HIDDEN HINGES), INTERNAL SHELF AND WIRE MANAGEMENT HOLES

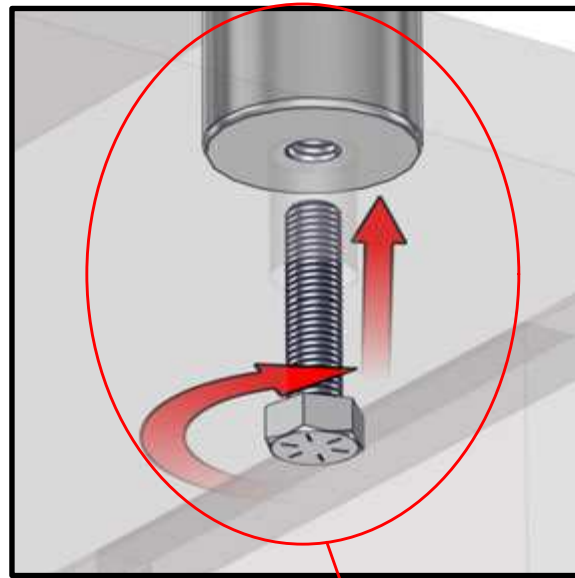

**R-HPC-01-B-CAB**

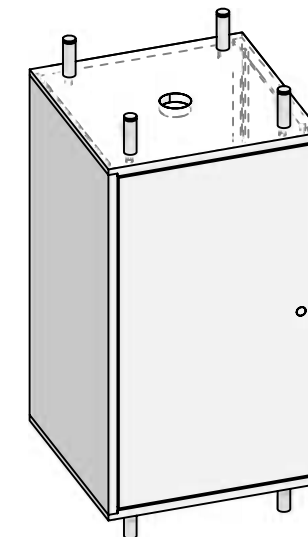
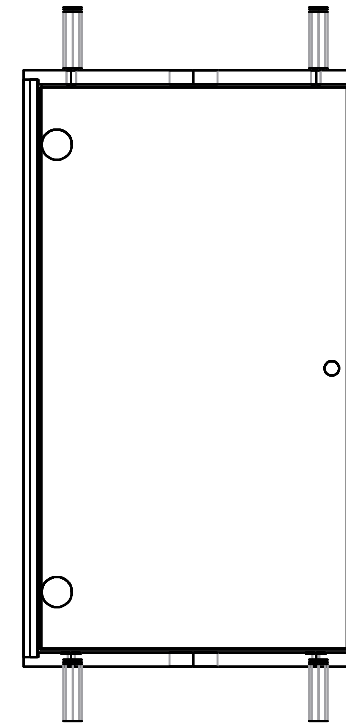
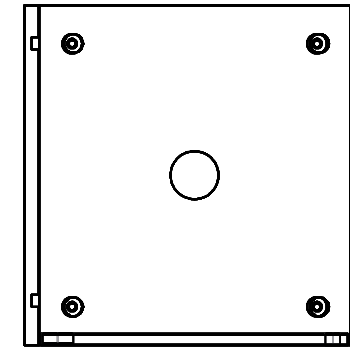
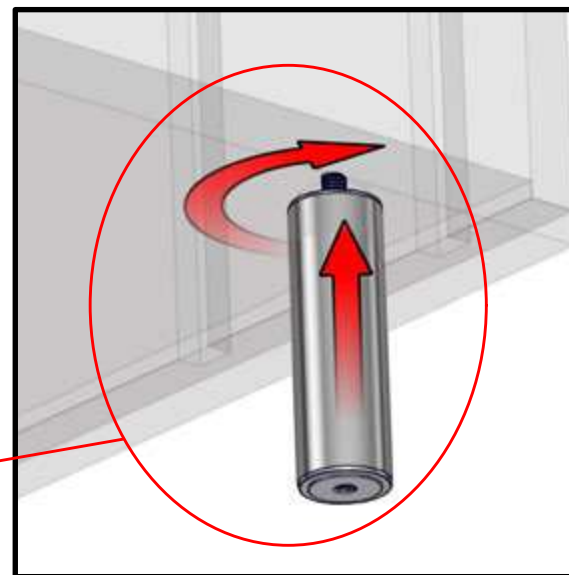
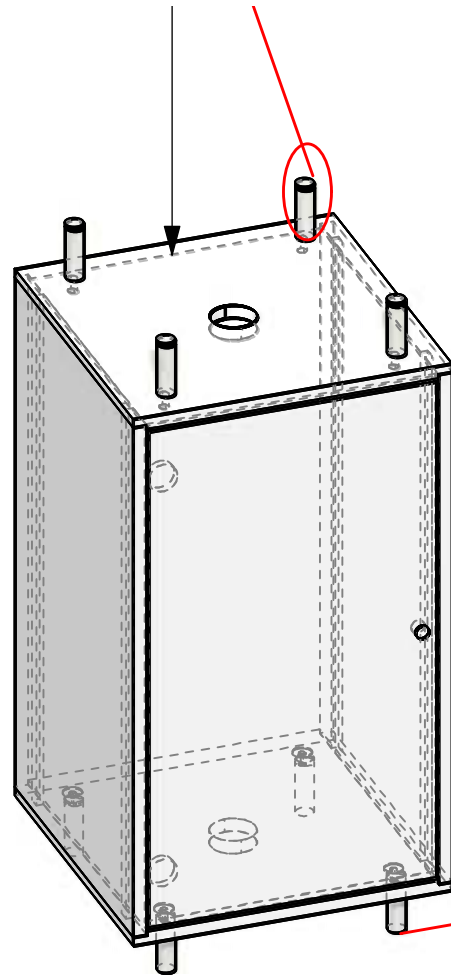

1. Redesign of this exhibit without approval by manufacturer may result in dangerous and unsafe structures. Manufacturer disclaims any responsibility for redesigned exhibits it does not approve in writing.

2. Parts and components such as panels and extrusions are manufactured to metric sizing. Where ever possible sizes have been noted in feet and inches as well as in metric. Below is the imperial to metric sizing table as reference. "Nominal" refers to approximate size.

2400mm = (94 1/2")	Phone Line / Fax
2100mm = (82 5/8")	Internet connection
1800mm = (70 7/8")	Outlet
1500mm = (59")	Main Drop (point of distrution)
1200mm = (47 1/4")	
900mm = (35 1/2")	
600mm = (23 5/8")	
300mm = (11 7/8")	

--- Wire running under carpet

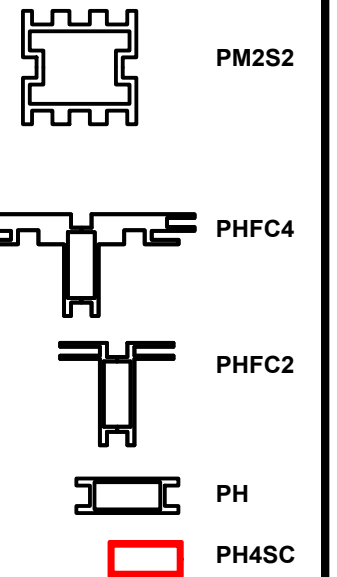

**HYBRID PRO RENTAL KIT**

Title: SET-UP INSTRUCTIONS

Code	#	Description
SS4	4	SILVER SS4 SHELF SUPPORTS
R-HPC-01-A-INT	1	2' X 2' X 5/8" INTERNAL SHELF FOR HPC-01-B

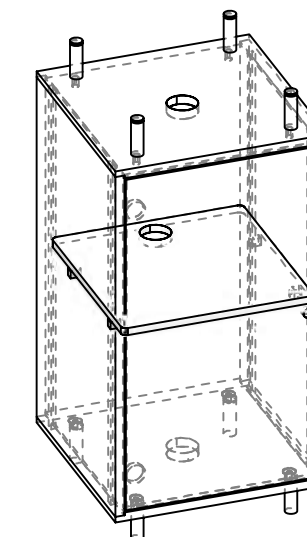
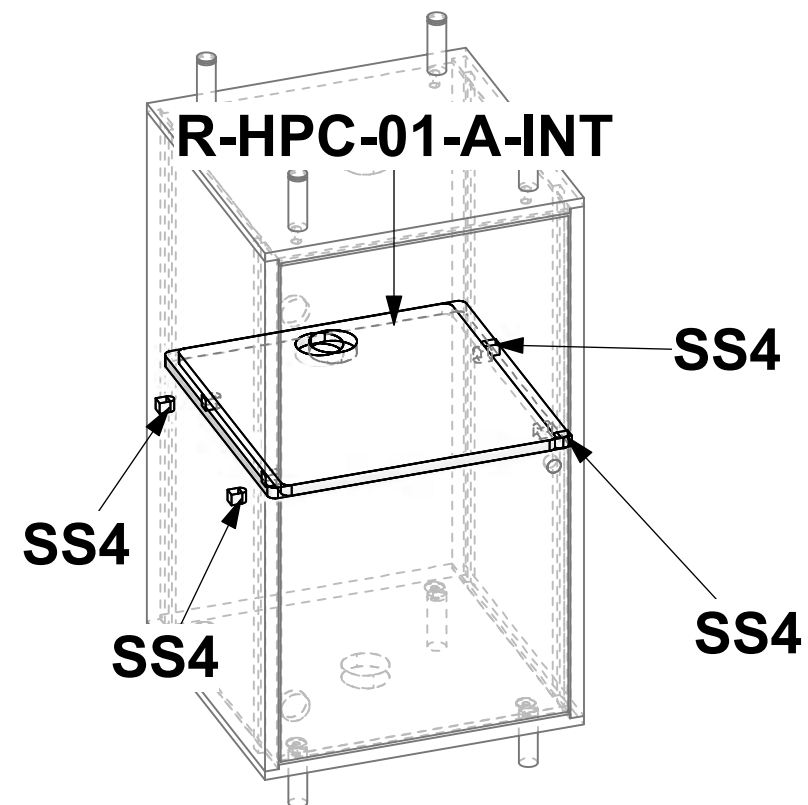
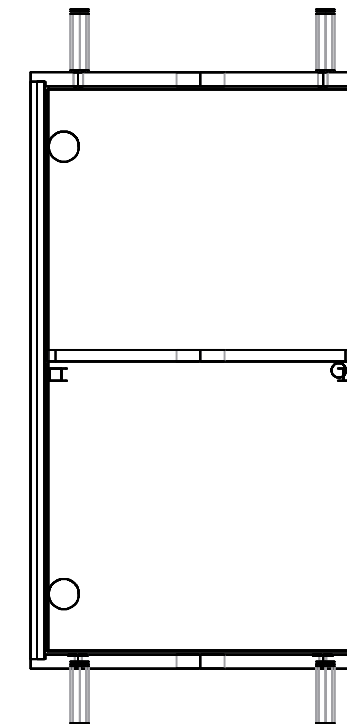
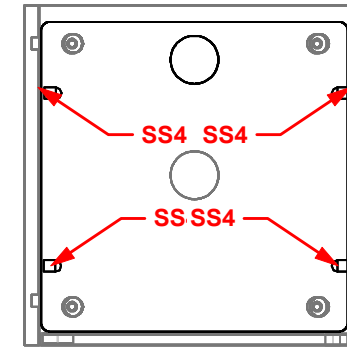
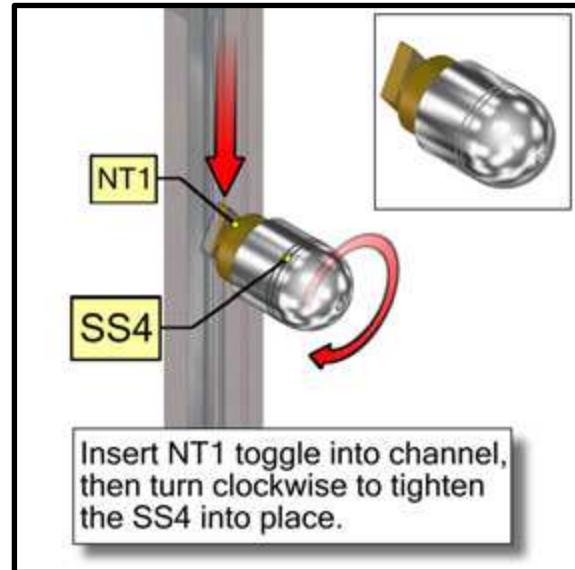

1. Redesign of this exhibit without approval by manufacturer may result in dangerous and unsafe structures. Manufacturer disclaims any responsibility for redesigned exhibits it does not approve in writing.

2. Parts and components such as panels and extrusions are manufactured to metric sizing. Where ever possible sizes have been noted in feet and inches as well as in metric. Below is the imperial to metric sizing table as reference. "Nominal" refers to approximate size.

2400mm = (94 1/2")	Phone Line / Fax
2100mm = (82 5/8")	Internet connection
1800mm = (70 7/8")	Outlet
1500mm = (59")	Main Drop (point of distrution)
1200mm = (47 1/4")	
900mm = (35 1/2")	
600mm = (23 5/8")	
300mm = (11 7/8")	

--- Wire running under carpet

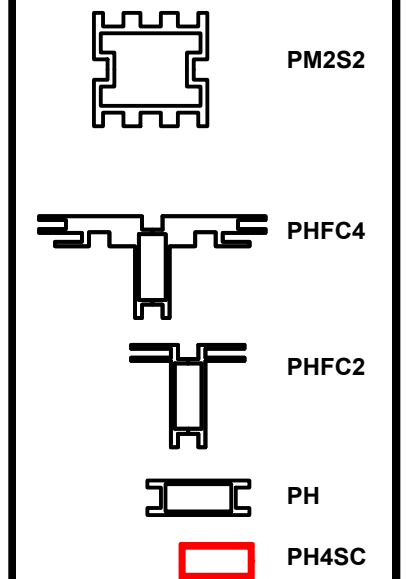

HYBRID PRO RENTAL KIT

Title: SET-UP INSTRUCTIONS

Code	#	Description
R-HPC-01-B-CT	1	4' X 2' X 2' L-SHAPED COUNTER TOP FOR R-HPC-01-A UNIT

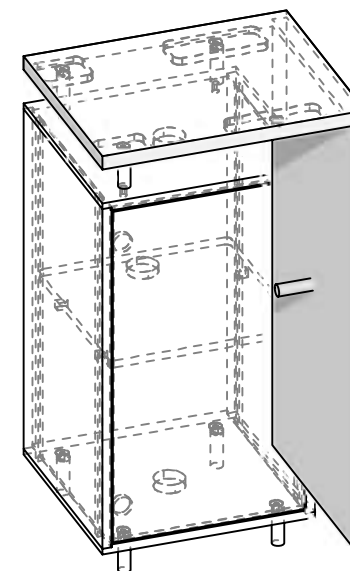
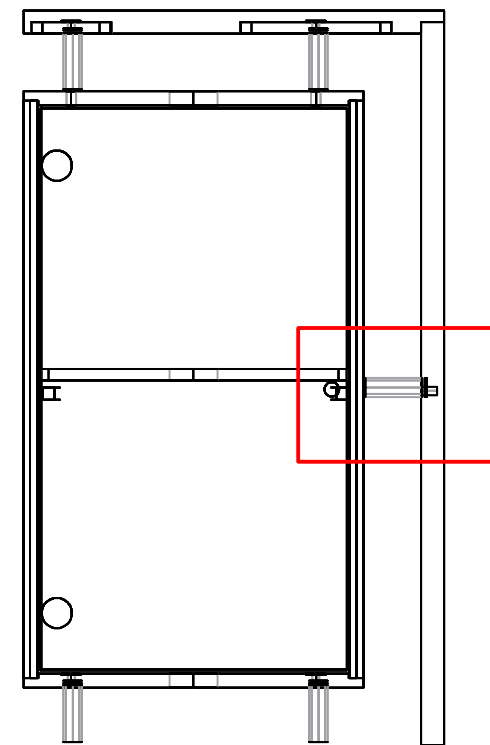
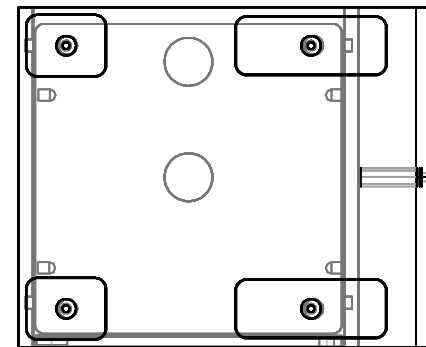
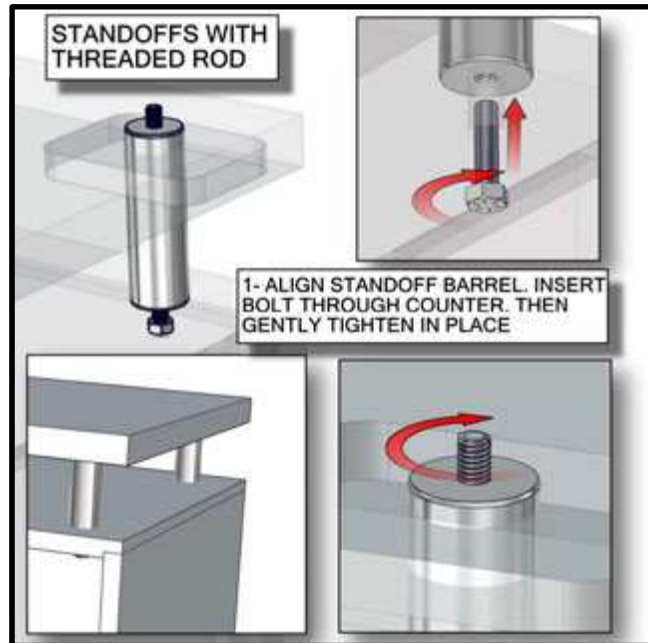

### R-HPC-01-B-CT

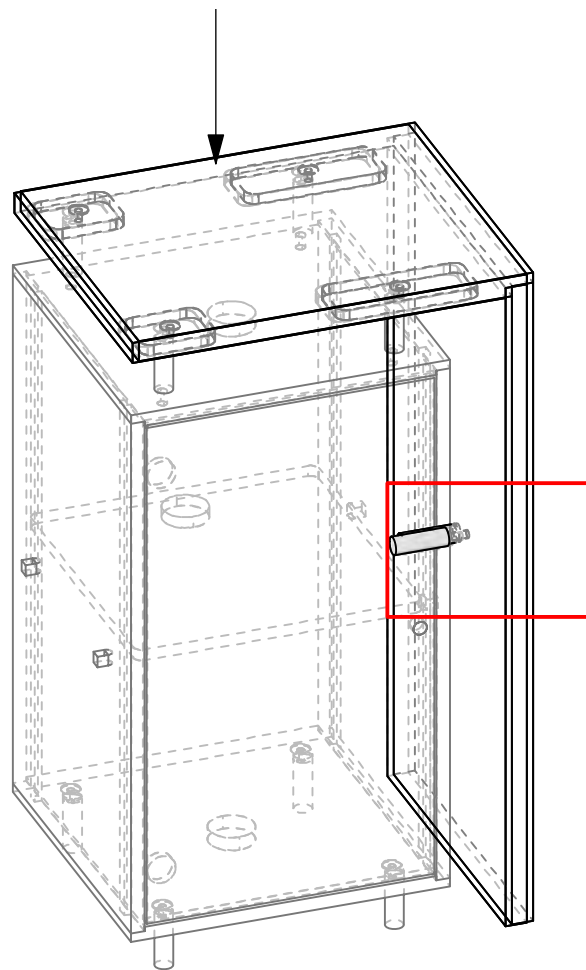

**STANDOFF ATTACH TO "L" SHAPED COUNTER ONLY!**

1. Redesign of this exhibit without approval by manufacturer may result in dangerous and unsafe structures. Manufacturer disclaims any responsibility for redesigned exhibits it does not approve in writing.

2. Parts and components such as panels and extrusions are manufactured to metric sizing. Where ever possible sizes have been noted in feet and inches as well as in metric. Below is the imperial to metric sizing table as reference. "Nominal" refers to approximate size.

2400mm = (94 1/2")	Phone Line / Fax
2100mm = (82 5/8")	Internet connection
1800mm = (70 7/8")	Outlet
1500mm = (59")	Main Drop (point of distrution)
1200mm = (47 1/4")	
900mm = (35 1/2")	
600mm = (23 5/8")	
300mm = (11 7/8")	

--- Wire running under carpet

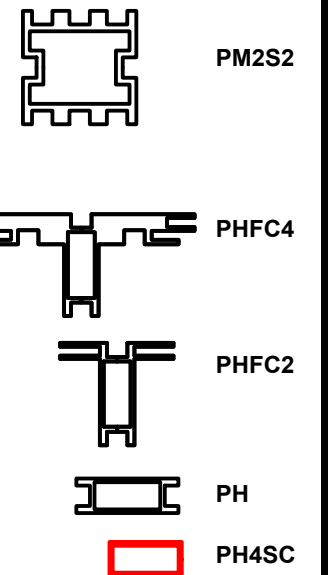

**HYBRID PRO RENTAL KIT**

Title: SET-UP INSTRUCTIONS





# **PACKING INSTRUCTIONS**



1

1 R-HPC-01-B

# CASE # 1

LEGEND	
	GREY FOAM FOLDED TO FILL EMPTY SPACES OR USED AS PROTECTION
	1/8" CARDBOARD SPACER (PUT IN BETWEEN EVERY PANEL)
	DIVIDER
	1/4" WHITE FOAM (USED AS PROTECTION DOOR PANELS W/ LOCKS)



WOODCRATE