

Hybrid Pro Modular Kit 04

HP-K-04

Hybrid Pro™ Modular exhibits and counters are a perfect solution for the serious exhibitor. Exhibits feature heavy-duty aluminum extrusion frames and push-fit fabric graphics. Count on making an unforgettable impact with Hybrid Pro Modular exhibit kits, counters, and accessories.

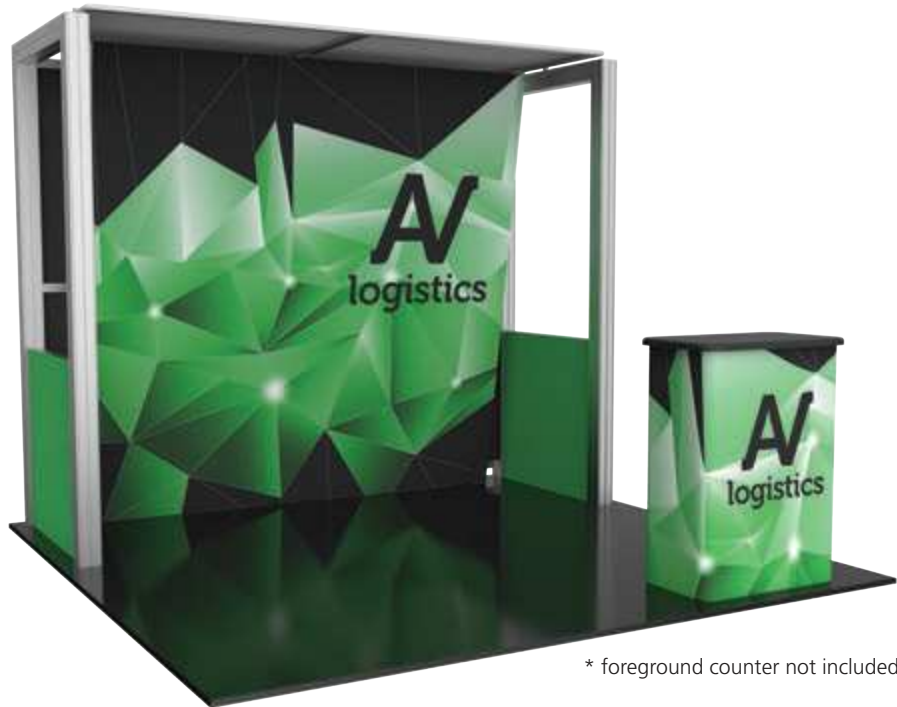

* foreground counter not included

features and benefits:

- Silver aluminum extrusion frame
- Single-sided SEG dye-sublimated push-fit fabric graphics - Sheer graphic with hook & loop on perimeter - UV graphic printed on 6mm white Sintra infills
- Kit includes frame, five fabric graphic panels, one sheer graphic, four white Sintra infills, and three molded OCH2 cases
- Lifetime hardware warranty against manufacturer defects

dimensions:

Hardware	Graphic
<p>Assembled unit: 114.13" w x 94.5" h x 33.25" d 2898.9mm(w) x 2400.3mm(h) x 844.55mm(d)</p>	<p>Total visual area: Dye Sub Graphic Panels A & I: 35.3135" w x 35.3125" h</p> <p>Dye Sub Graphic Panels B & H: 35.3125" w x 35.3125" h (graphic has obstruction)</p> <p>UV Graphic Panels C, D, F, G (6mm Sintra): 7.87" w x 42.62" h</p>
<p>Shipping</p> <p>Shipping dimensions - ships in 3 cases: 3 OCH2 cases (each case): 52" l x 30" w x 14" h 1320.8mm(l) x 762mm(w) x 355.6mm(h)</p> <p>Approximate shipping weight (entire kit): 431 lbs / 195.5 kgs</p>	<p>Dye Sub Fabric Structure J (sheer; Hook & Loop applied to top of frame): 111" w x 39" h</p> <p>Please consider obstructions and spaces created by the extrusions when designing graphics.</p> <p>Be sure to include a 2" bleed around the perimeter of the dye-sub graphics and a .5" bleed around the perimeter of panels C, D, F and G.</p>

additional information:

Fabric material: Dye-sublimated fabric and UV printed on 6mm white Sintra infills

*Foreground counter not included



ZZZ FDPHOEDFNGLVSO\

We are continually improving and modifying our product range and reserve the right to vary the specifications without prior notice. All dimensions and weights quoted are approximate and we accept no responsibility for variance. E&OE. See Graphic Templates for graphic bleed specifications.

R-HP-K-04

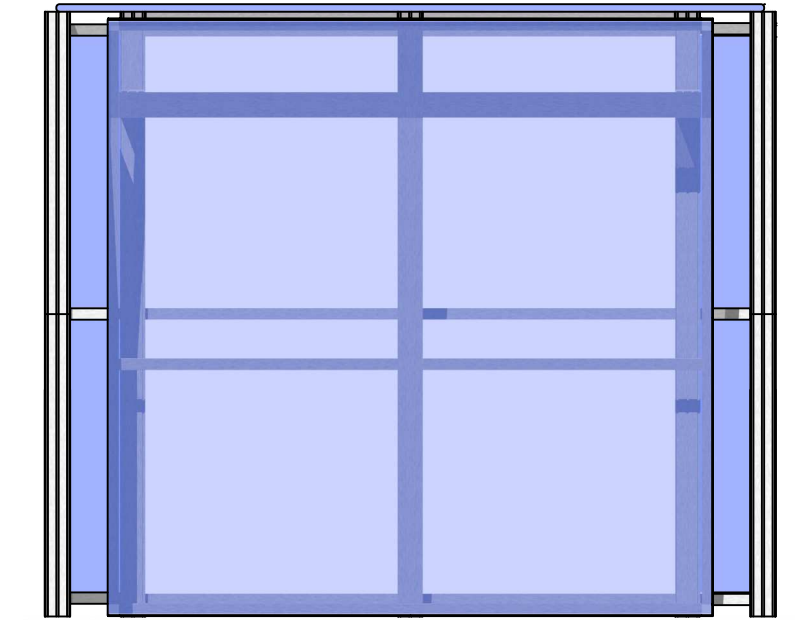
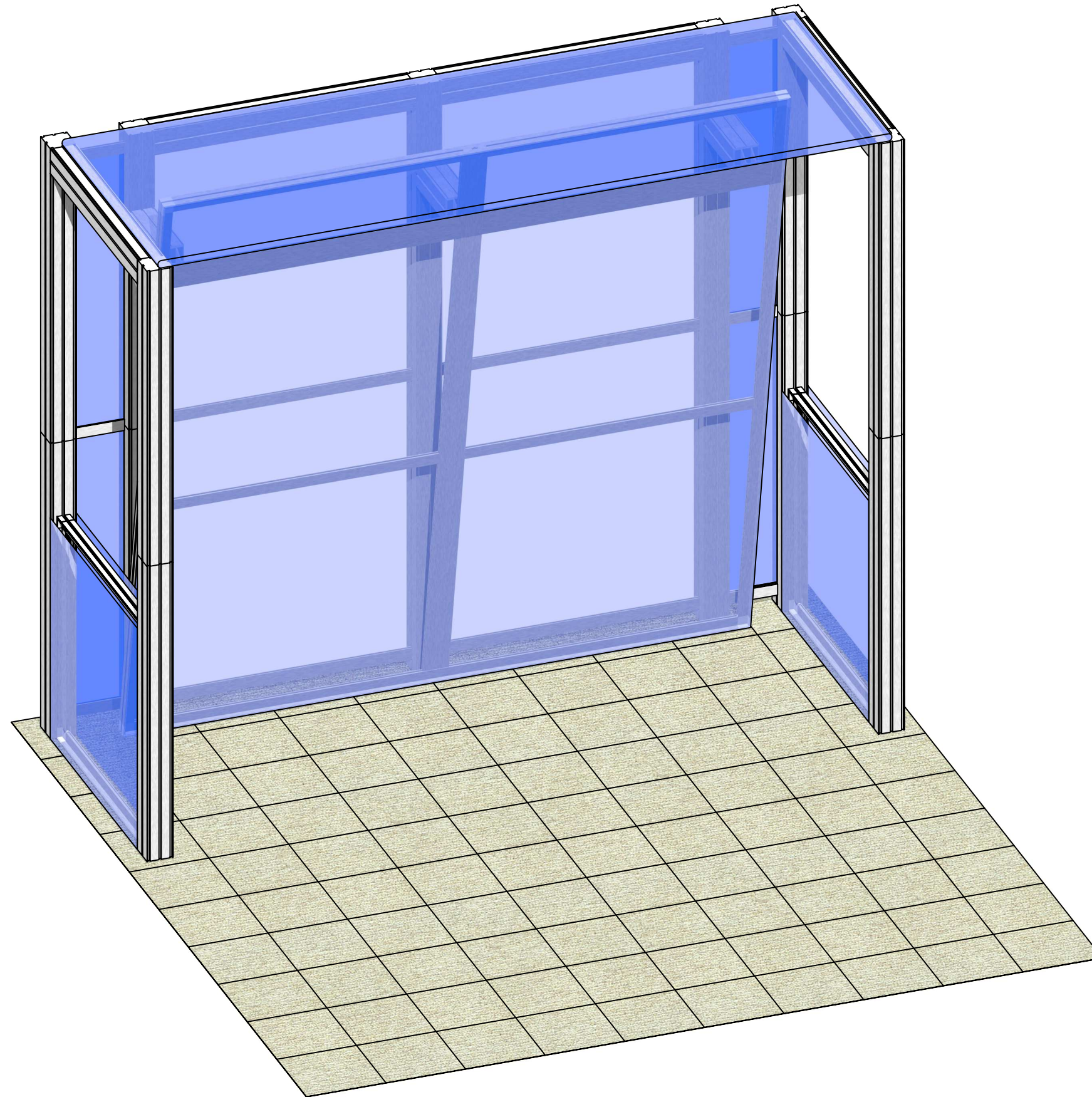

BOM

Code	#	Description
R15	14	1200MM (47.24") 100MM PM4S2 SQUARE EXTRUSION WITH PH2 STOP AT 305MM BOTH ENDS
R30	4	810MM (31.89") PHFC2 EXTRUSION WITH LOCKS 2 ENDS
R29	4	810MM (31.89") PHFC2 EXTRUSION WITH LOCKS 2 ENDS WITH SIDE CAM LOCKS
GRAPHIC A2	1	35.43"H X 35.43"W SINGLE SIDED DYESUB GRAPHIC W/FCE-2 ON PERIMETER
PM4 HINGE	3	90 DEG PM4 HINGE (POWDERCOATED 9006)
R36	3	300MM (11.81") 100MM PM4S2 SQUARE EXTRUSION WITH LOCKS 2 ENDS
R62	4	1000MM (39.37") PH EXTRUSION WITH LOCKS 2 ENDS
R34	2	1000MM (39.37") 100MM PM4S2 SQUARE EXTRUSION WITH LOCKS 2 ENDS
R35	2	900MM (35.43") 100MM PM4S2 SQUARE EXTRUSION WITH LOCKS 2 ENDS
R31	6	200MM (7.87") PH EXTRUSION WITH LOCKS 2 ENDS
R13	7	600MM (23.62") PM4D CONNECTOR WITH TENSION GLIDES
GRAPHIC B1	1	42.62"H X 7.87"W DSG GRAPHIC ON 6MM WHITE SINTRA - INFILL
GRAPHIC B2	1	42.62"H X 7.87"W DSG GRAPHIC ON 6MM WHITE SINTRA - INFILL
GRAPHIC B3	1	42.62"H X 7.87"W DSG GRAPHIC ON 6MM WHITE SINTRA - INFILL
GRAPHIC B4	1	42.62"H X 7.87"W DSG GRAPHIC ON 6MM WHITE SINTRA - INFILL
GRAPHIC A1	1	35.43"H X 35.43"W SINGLE SIDED DYESUB GRAPHIC W/FCE-2 ON PERIMETER
GRAPHIC A3	1	35.43"H X 35.43"W SINGLE SIDED DYESUB GRAPHIC W/FCE-2 ON PERIMETER
GRAPHIC A4	1	35.43"H X 35.43"W SINGLE SIDED DYESUB GRAPHIC W/FCE-2 ON PERIMETER
R38	2	1155MM (45.47") PS2 EXTRUSION WITH LOCK 1 END - IB2 HOLE OTHER END
R33	2	1105MM (43.50") PS2 EXTRUSION WITH SLIDE LOCKS BOTH ENDS
IB2	6	PH INLINE CONNECTOR
GRAPHIC D	1	110 9/16" (H) X 39" (W) X 30MM TUBING - FABRIC STRUCTURE- ATTACHED USING TCH-30 CLAMPS
R32	2	1105MM (43.50") PH EXTRUSION WITH SLIDE LOCKS 2 ENDS
CB9-S	12	50MM SQUARE PHFC2 CORNER BRACKET
R28	8	1155MM (45.47") PHFC2 EXTRUSION WITH IB2 HOLE ONE SIDE-WITH LOCK 1 END
GRAPHIC C□□	1	94 1/2" (H) X 94 1/2" (W) SINGLE SIDED DYESUB GRAPHIC W/ FCE-2 (SEG) ON PERIMETER

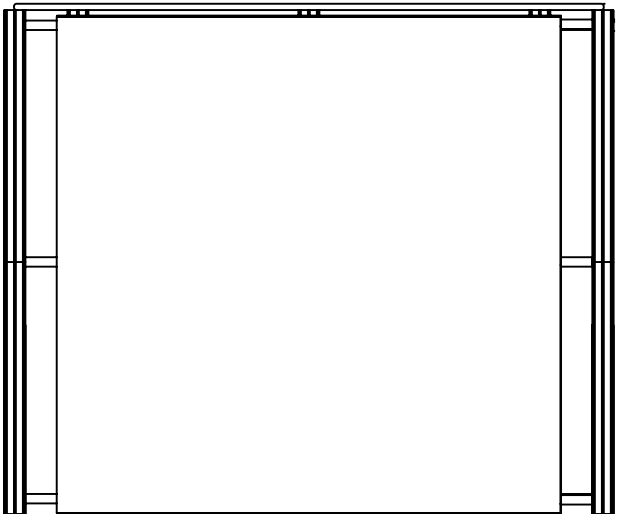
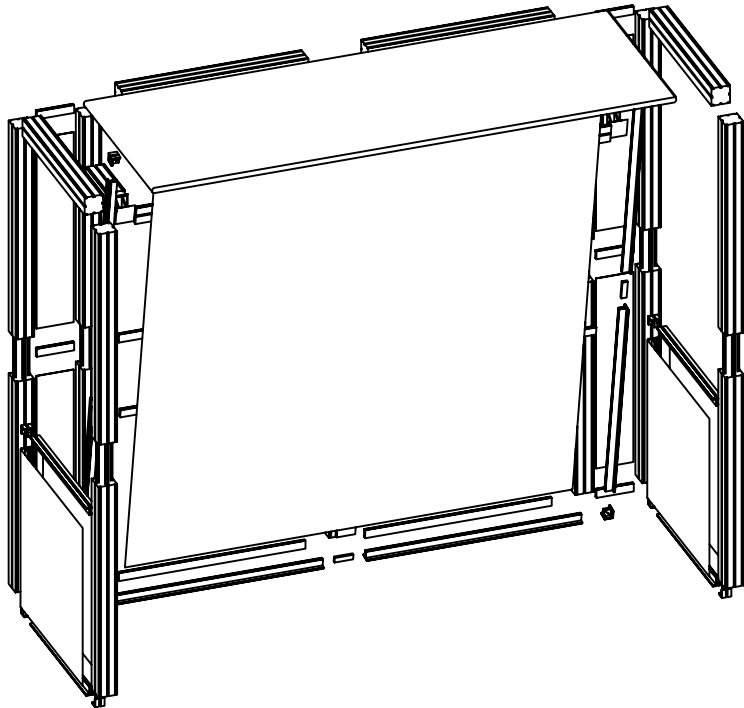
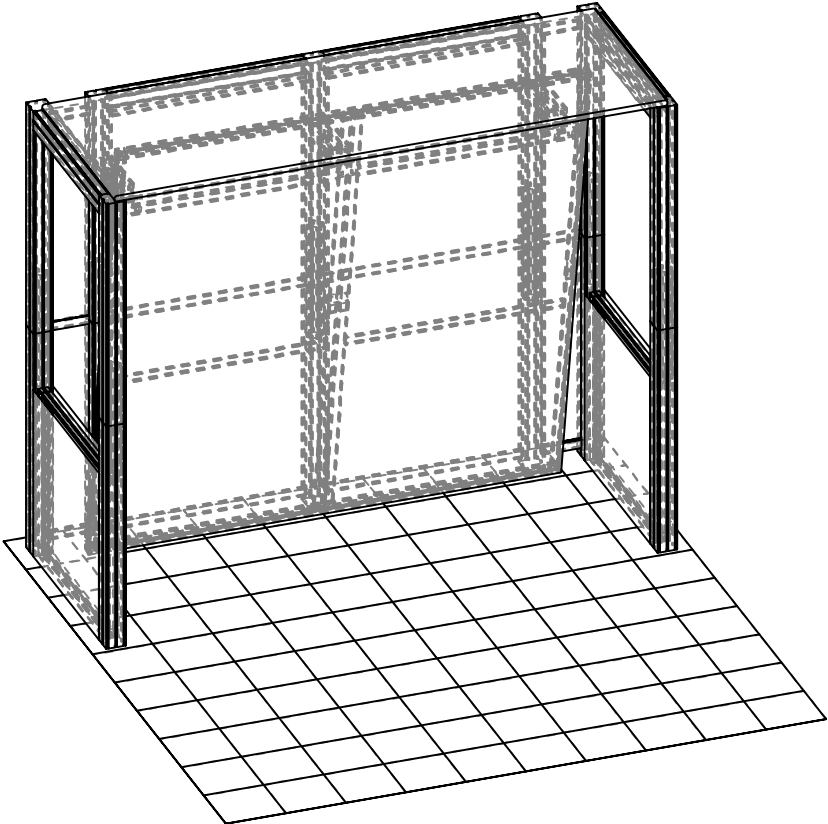
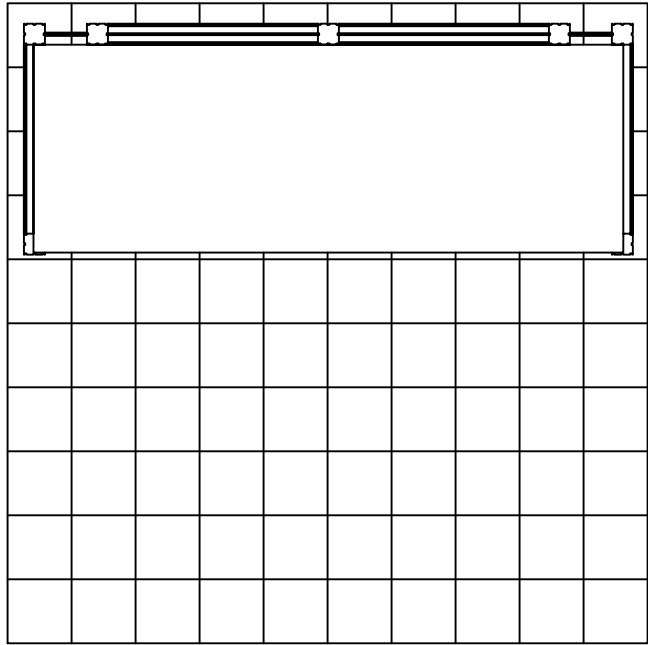

1. Redesign of this exhibit without approval by manufacturer may result in dangerous and unsafe structures. Manufacturer disclaims any responsibility for redesigned exhibits it does not approve in writing.

2. Parts and components such as panels and extrusions are manufactured to metric sizing. Where ever possible sizes have been noted in feet and inches as well as in metric. Below is the imperial to metric sizing table as reference. "Nominal" refers to approximate size.

- | | |
|--------------------|-----------------------------------|
| 2400mm = (94 1/2") | ▼ Phone Line / Fax |
| 2100mm = (82 5/8") | ▼ Internet connection |
| 1800mm = (70 7/8") | ▼ Outlet |
| 1500mm = (59") | ▼ Main Drop (point of distrution) |
| 1200mm = (47 1/4") | |
| 900mm = (35 1/2") | |
| 600mm = (23 5/8") | |
| 300mm = (11 7/8") | |
- Wire running under carpet

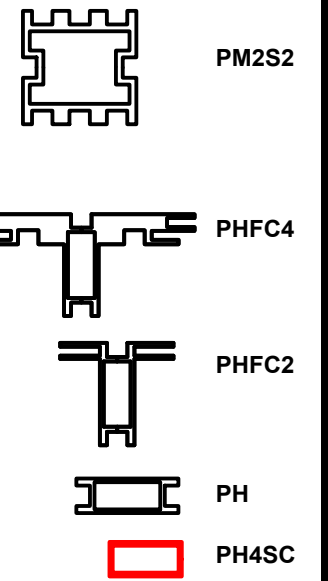
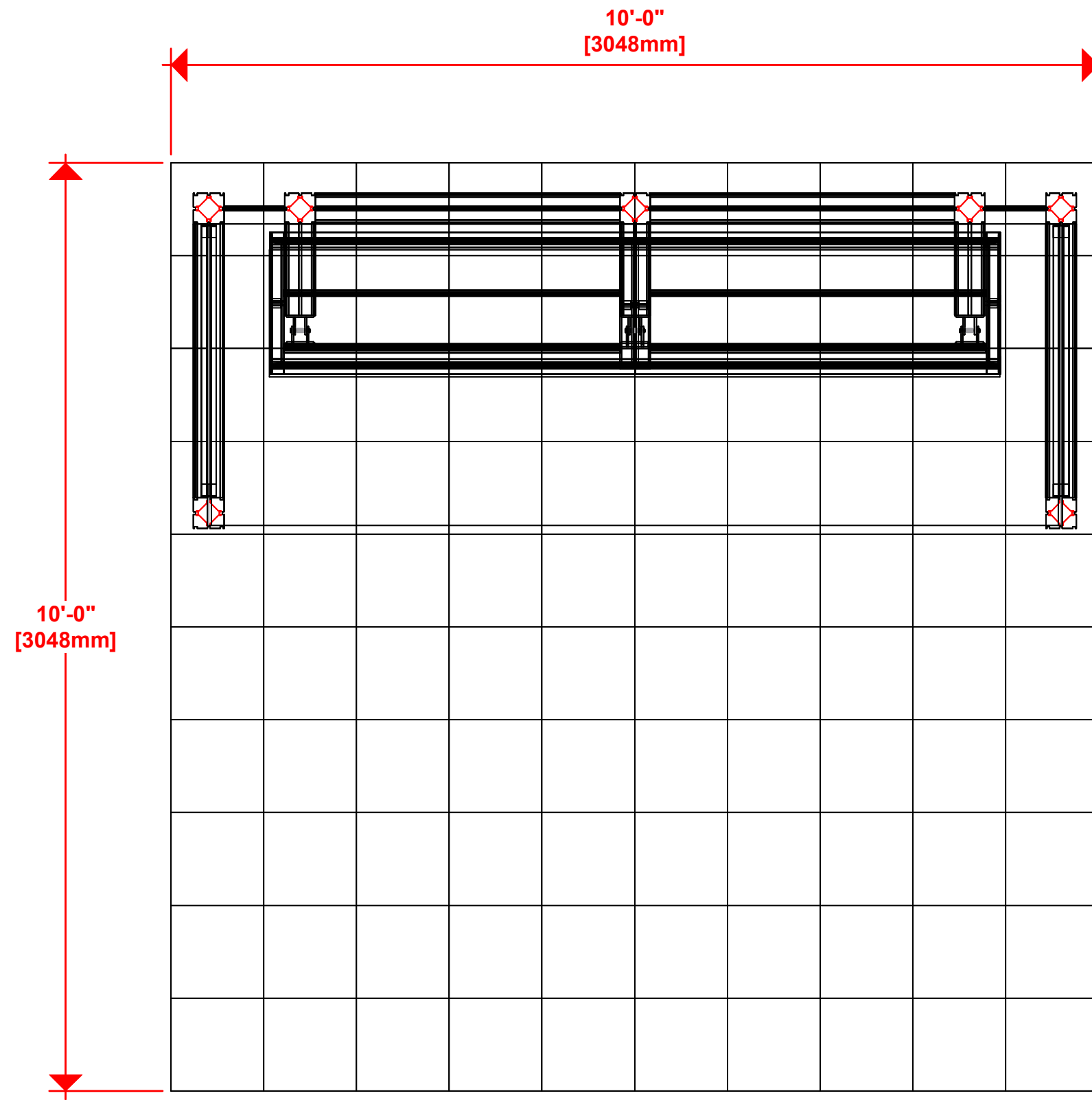

HYBRID PRO RENTAL KIT

Title: SET-UP INSTRUCTIONS

Code	#	Description
R30	4	810MM (31.89") PHFC2 EXTRUSION WITH LOCKS 2 ENDS
R29	4	810MM (31.89") PHFC2 EXTRUSION WITH LOCKS 2 ENDS WITH SIDE CAM LOCK
CB9-S	8	50MM SQUARE PHCF2 CORNER BRACKET

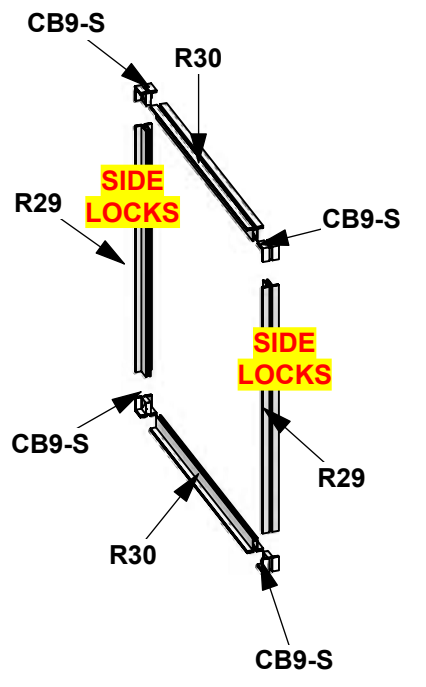
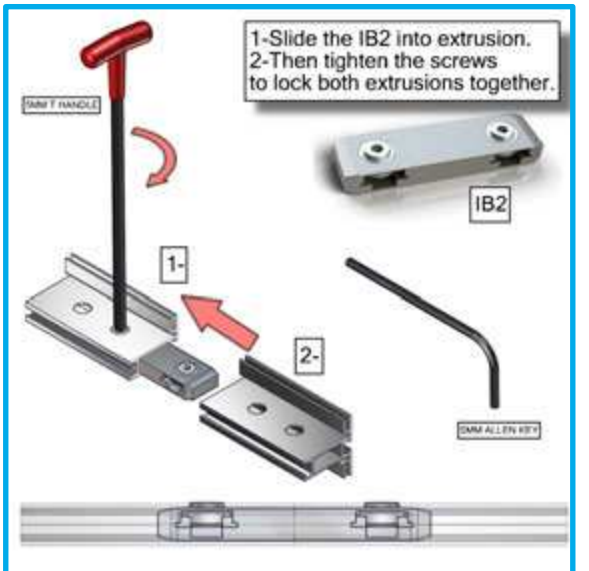
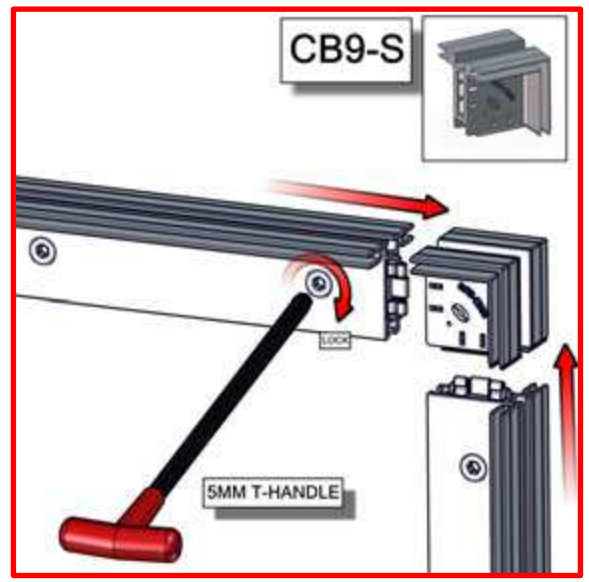

BUILD 2 UNITS

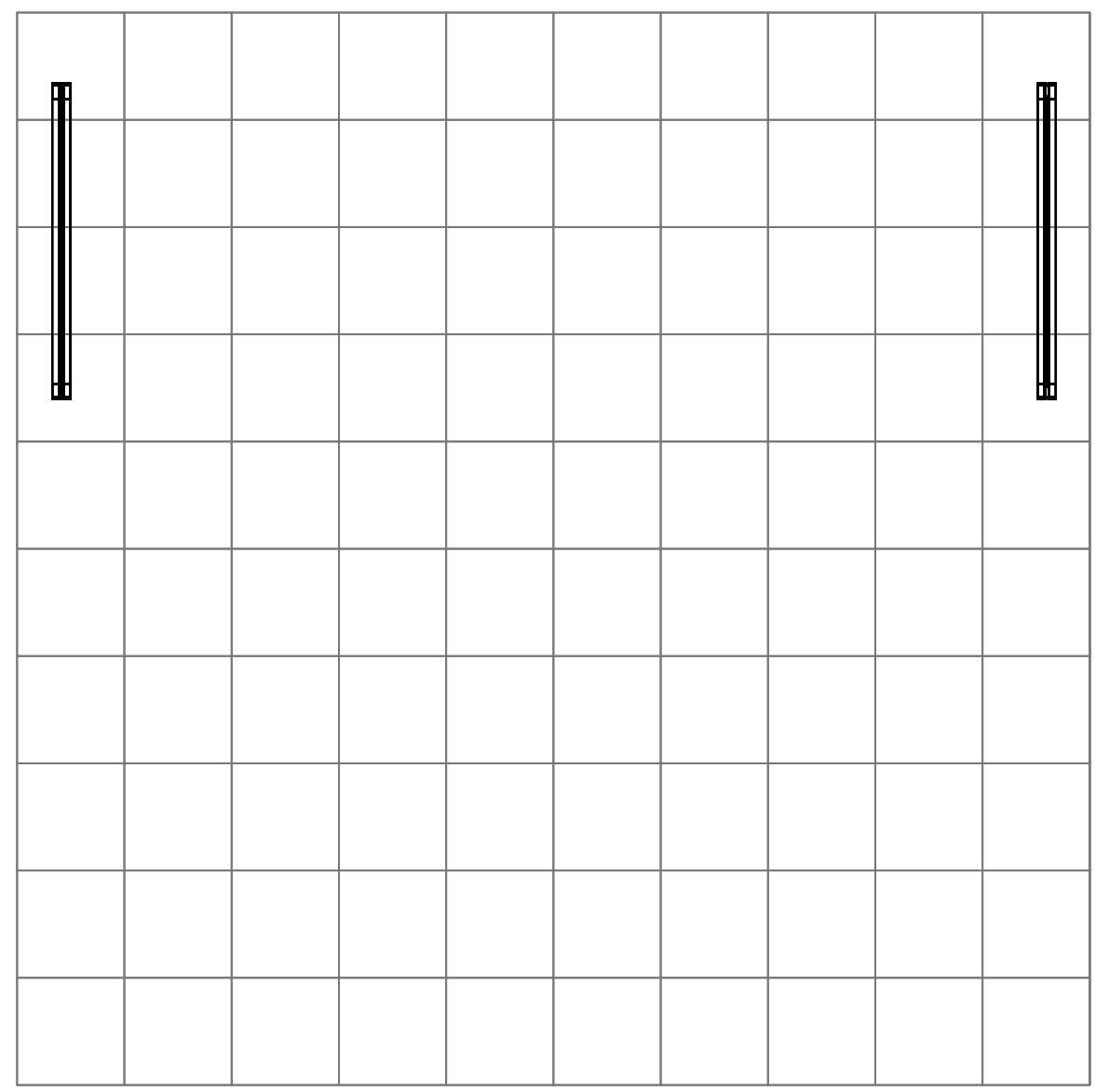

1. Redesign of this exhibit without approval by manufacturer may result in dangerous and unsafe structures. Manufacturer disclaims any responsibility for redesigned exhibits it does not approve in writing.

2. Parts and components such as panels and extrusions are manufactured to metric sizing. Where ever possible sizes have been noted in feet and inches as well as in metric. Below is the imperial to metric sizing table as reference. "Nominal" refers to approximate size.

2400mm = (94 1/2")	Phone Line / Fax
2100mm = (82 5/8")	Internet connection
1800mm = (70 7/8")	Outlet
1500mm = (59")	Main Drop (point of distrution)
1200mm = (47 1/4")	
900mm = (35 1/2")	
600mm = (23 5/8")	
300mm = (11 7/8")	

--- Wire running under carpet

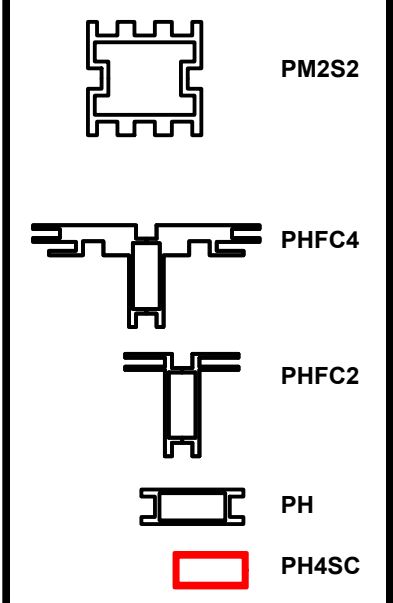

HYBRID PRO RENTAL KIT

Title: SET-UP INSTRUCTIONS

Code	#	Description
R15	5	1200MM (47.24") 100MM PM4S2 SQUARE EXTRUSION WITH PH2 STOP AT 305MM BO
R62	2	1000MM (39.37") PH EXTRUSION WITH LOCKS 2 ENDS
R31	2	200MM (7.87") PH EXTRUSION WITH LOCKS 2 ENDS
GRAPHIC B2	1	42.62"H X 7.87"W DSG GRAPHIC ON 6MM WHITE SINTRA - INFILL
GRAPHIC B4	1	42.62"H X 7.87"W DSG GRAPHIC ON 6MM WHITE SINTRA - INFILL

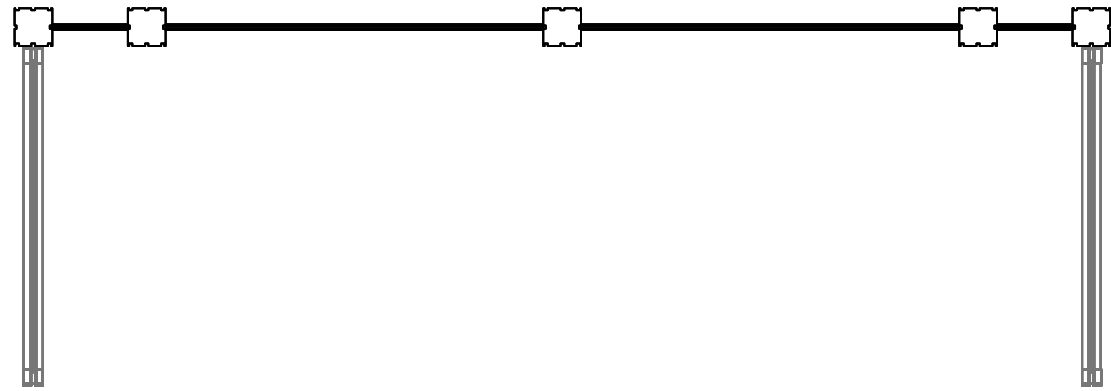
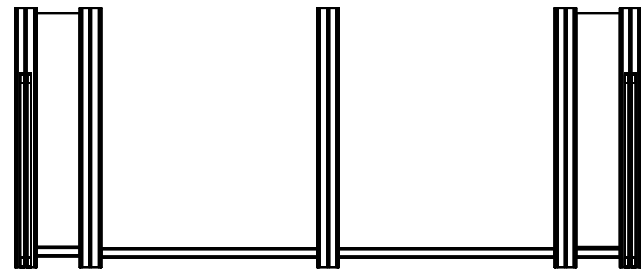

1. Redesign of this exhibit without approval by manufacturer may result in dangerous and unsafe structures. Manufacturer disclaims any responsibility for redesigned exhibits it does not approve in writing.

2. Parts and components such as panels and extrusions are manufactured to metric sizing. Where ever possible sizes have been noted in feet and inches as well as in metric. Below is the imperial to metric sizing table as reference. "Nominal" refers to approximate size.

2400mm = (94 1/2")	Phone Line / Fax
2100mm = (82 5/8")	Internet connection
1800mm = (70 7/8")	Outlet
1500mm = (59")	Main Drop (point of distrution)
1200mm = (47 1/4")	
900mm = (35 1/2")	
600mm = (23 5/8")	
300mm = (11 7/8")	

--- Wire running under carpet

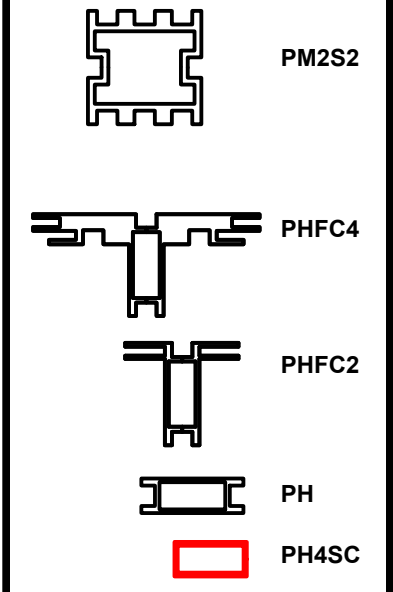
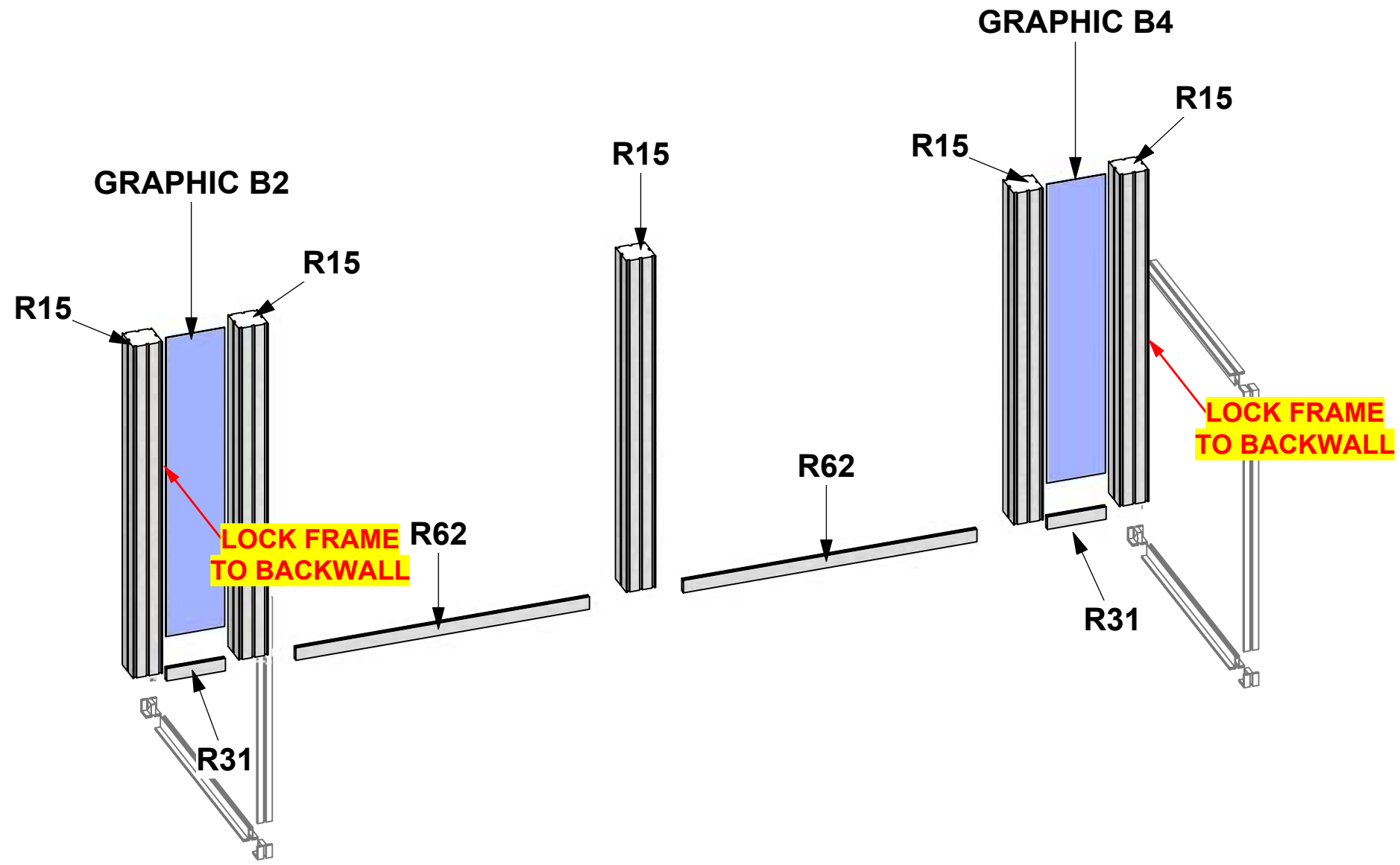

HYBRID PRO RENTAL KIT

Title: SET-UP INSTRUCTIONS

Code	#	Description
R62	2	1000MM (39.37") PH EXTRUSION WITH LOCKS 2 ENDS
R13	5	600MM (23.62") PM4D CONNECTOR WITH TENSION GLIDES
R31	2	200MM (7.87") PH EXTRUSION WITH LOCKS 2 ENDS

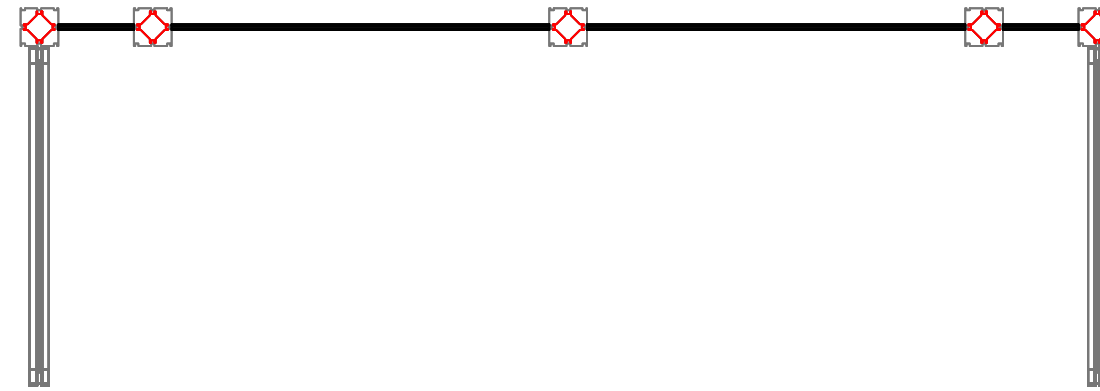
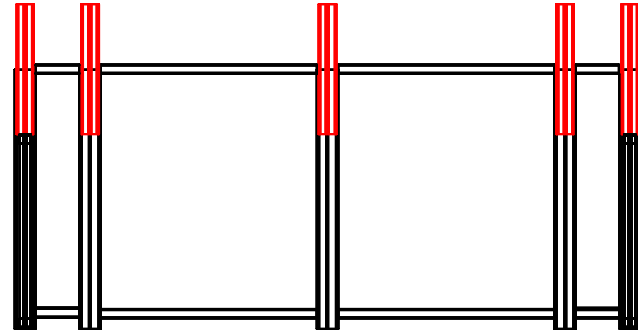

1. Redesign of this exhibit without approval by manufacturer may result in dangerous and unsafe structures. Manufacturer disclaims any responsibility for redesigned exhibits it does not approve in writing.

2. Parts and components such as panels and extrusions are manufactured to metric sizing. Where ever possible sizes have been noted in feet and inches as well as in metric. Below is the imperial to metric sizing table as reference. "Nominal" refers to approximate size.

2400mm = (94 1/2")	Phone Line / Fax
2100mm = (82 5/8")	Internet connection
1800mm = (70 7/8")	Outlet
1500mm = (59")	Main Drop (point of distrution)
1200mm = (47 1/4")	
900mm = (35 1/2")	
600mm = (23 5/8")	
300mm = (11 7/8")	

--- Wire running under carpet

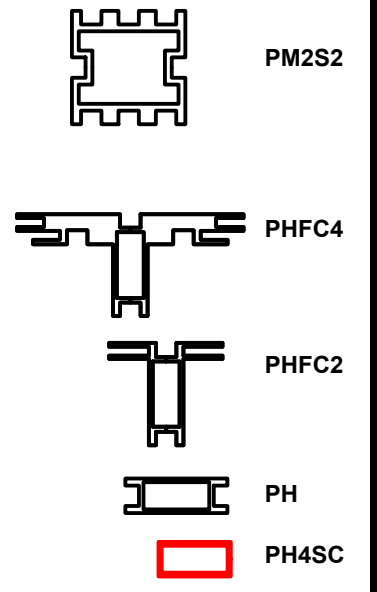
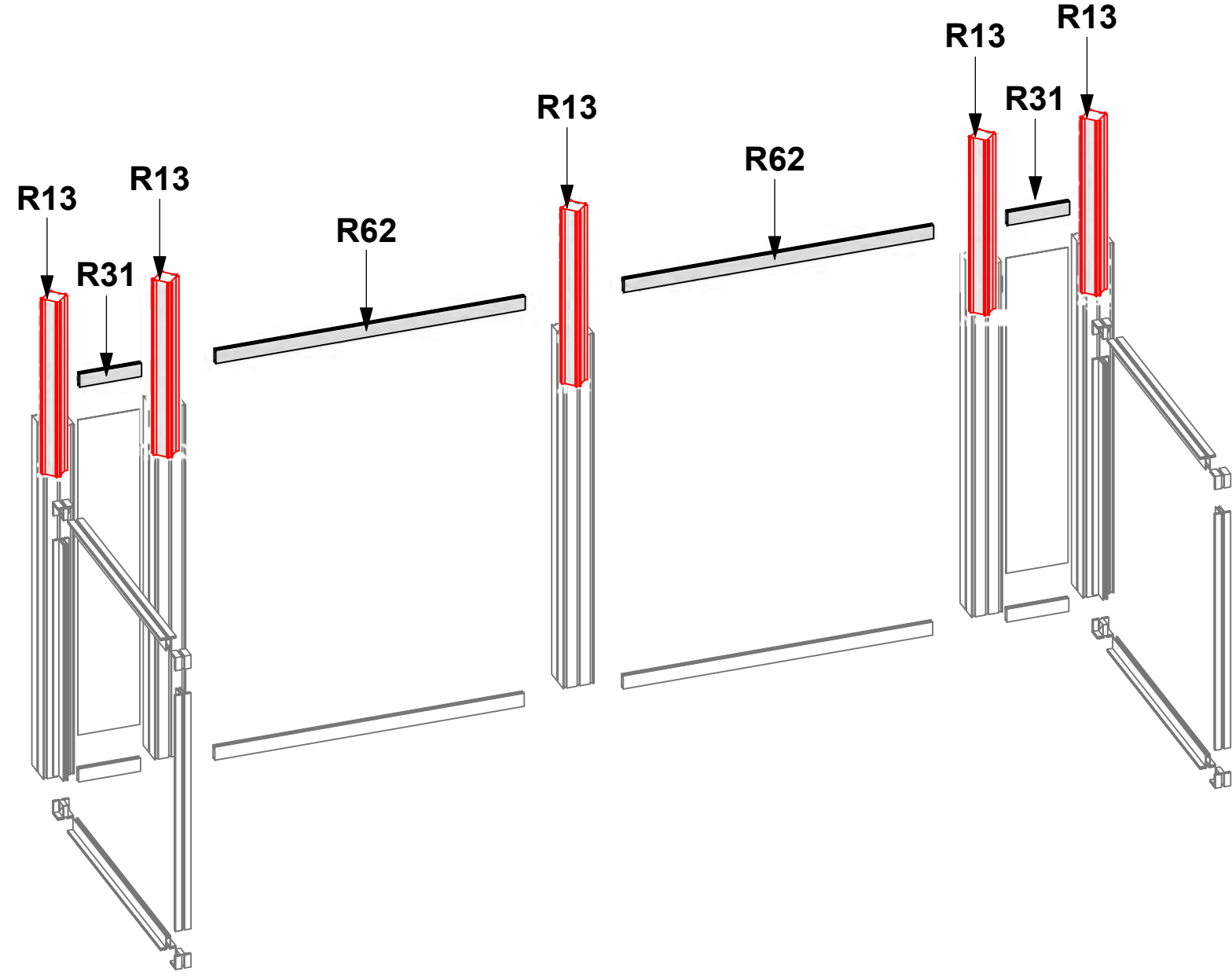
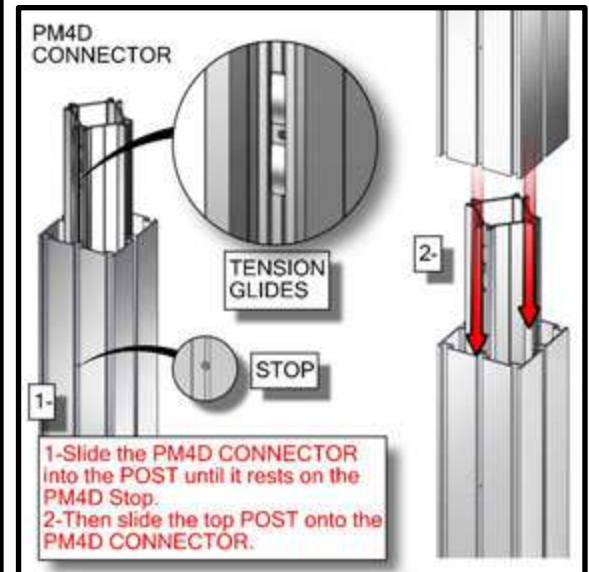

HYBRID PRO RENTAL KIT

Title: SET-UP INSTRUCTIONS

Code	#	Description
R34	2	1000MM (39.37") 100MM PM4S2 SQUARE EXTRUSION WITH LOCKS 2 ENDS
R31	2	200MM (7.87") PH EXTRUSION WITH LOCKS 2 ENDS
R15	5	1200MM (47.24") 100MM PM4S2 SQUARE EXTRUSION WITH PH2 STOP AT 305MM B
GRAPHIC B1	1	42.62"H X 7.87"W DSG GRAPHIC ON 6MM WHITE SINTRA - INFILL
GRAPHIC B3	1	42.62"H X 7.87"W DSG GRAPHIC ON 6MM WHITE SINTRA - INFILL

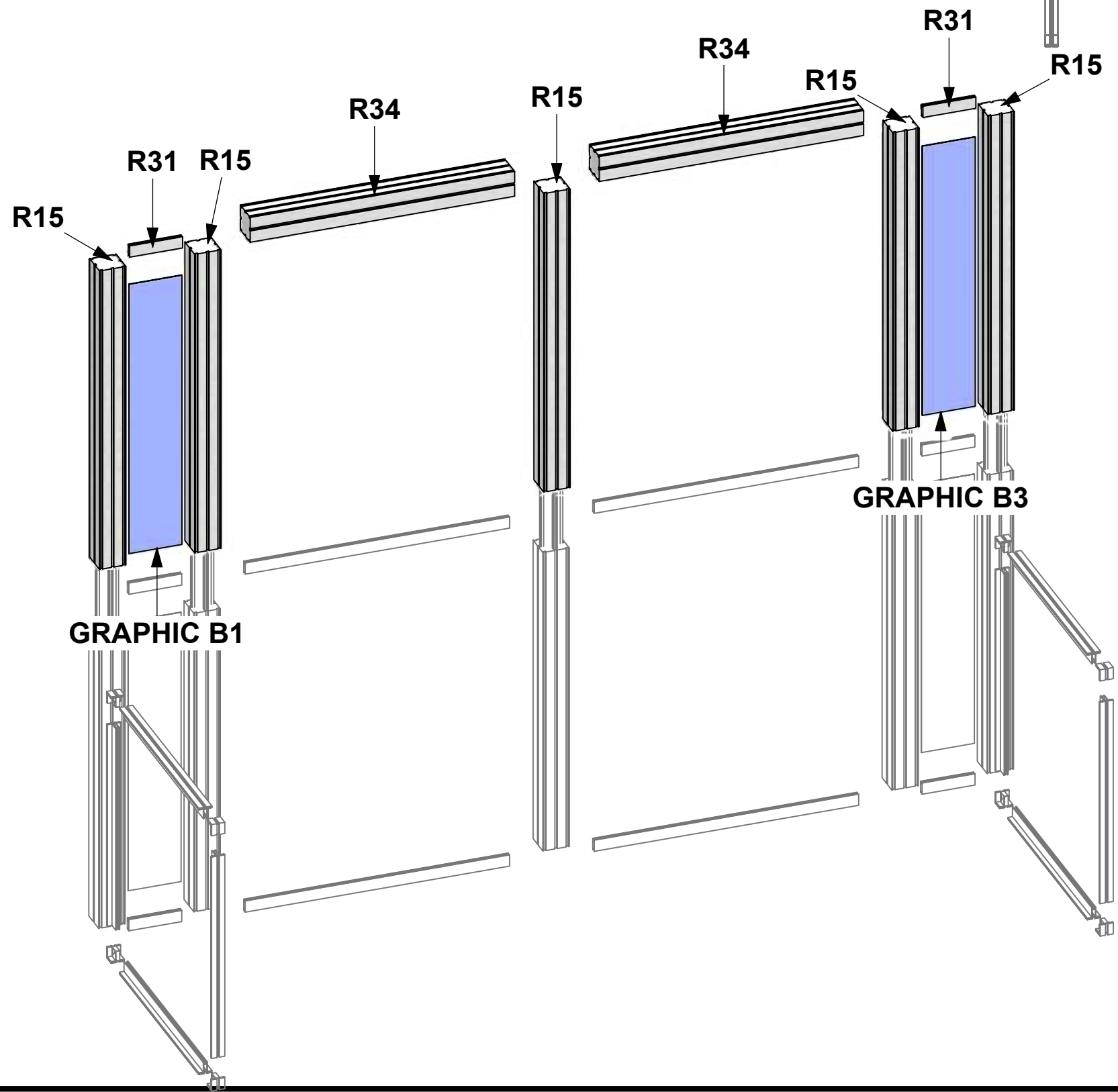

1. Redesign of this exhibit without approval by manufacturer may result in dangerous and unsafe structures. Manufacturer disclaims any responsibility for redesigned exhibits it does not approve in writing.

2. Parts and components such as panels and extrusions are manufactured to metric sizing. Where ever possible sizes have been noted in feet and inches as well as in metric. Below is the imperial to metric sizing table as reference. "Nominal" refers to approximate size.

2400mm = (94 1/2")	Phone Line / Fax
2100mm = (82 5/8")	Internet connection
1800mm = (70 7/8")	Outlet
1500mm = (59")	Main Drop (point of distrution)
1200mm = (47 1/4")	
900mm = (35 1/2")	
600mm = (23 5/8")	
300mm = (11 7/8")	

--- Wire running under carpet

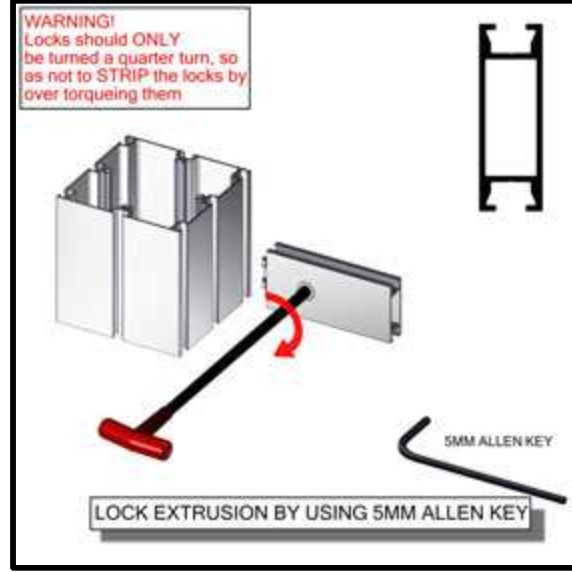
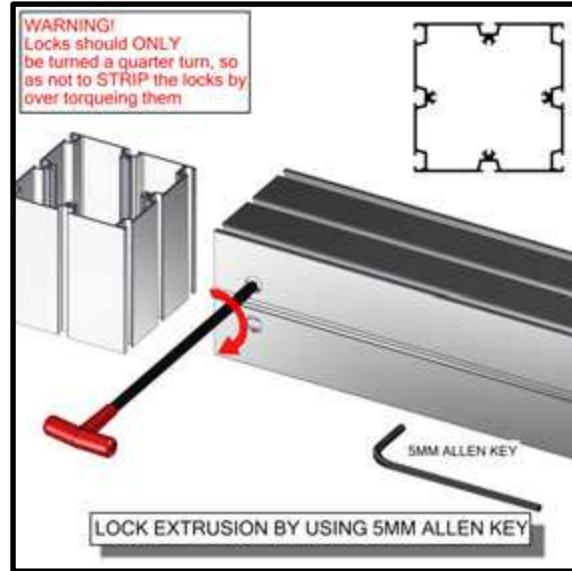
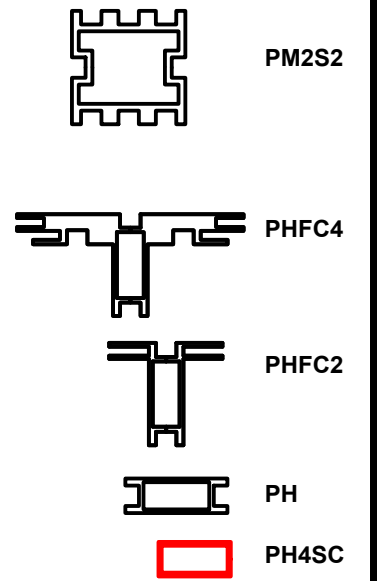

HYBRID PRO RENTAL KIT

Title: SET-UP INSTRUCTIONS

Code	#	Description
R15	4	1200MM (47.24") 100MM PM4S2 SQUARE EXTRUSION
R35	2	900MM (35.43") 100MM PM4S2 SQUARE EXTRUSION
R13	2	600MM (23.62") PM4D CONNECTOR WITH TENSION GLIDES

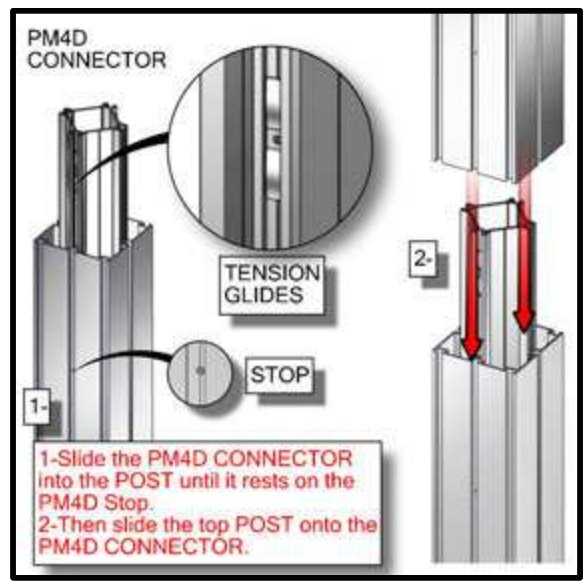
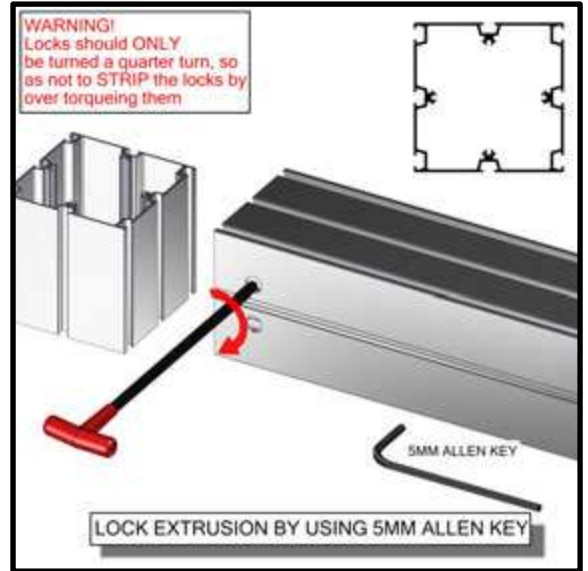
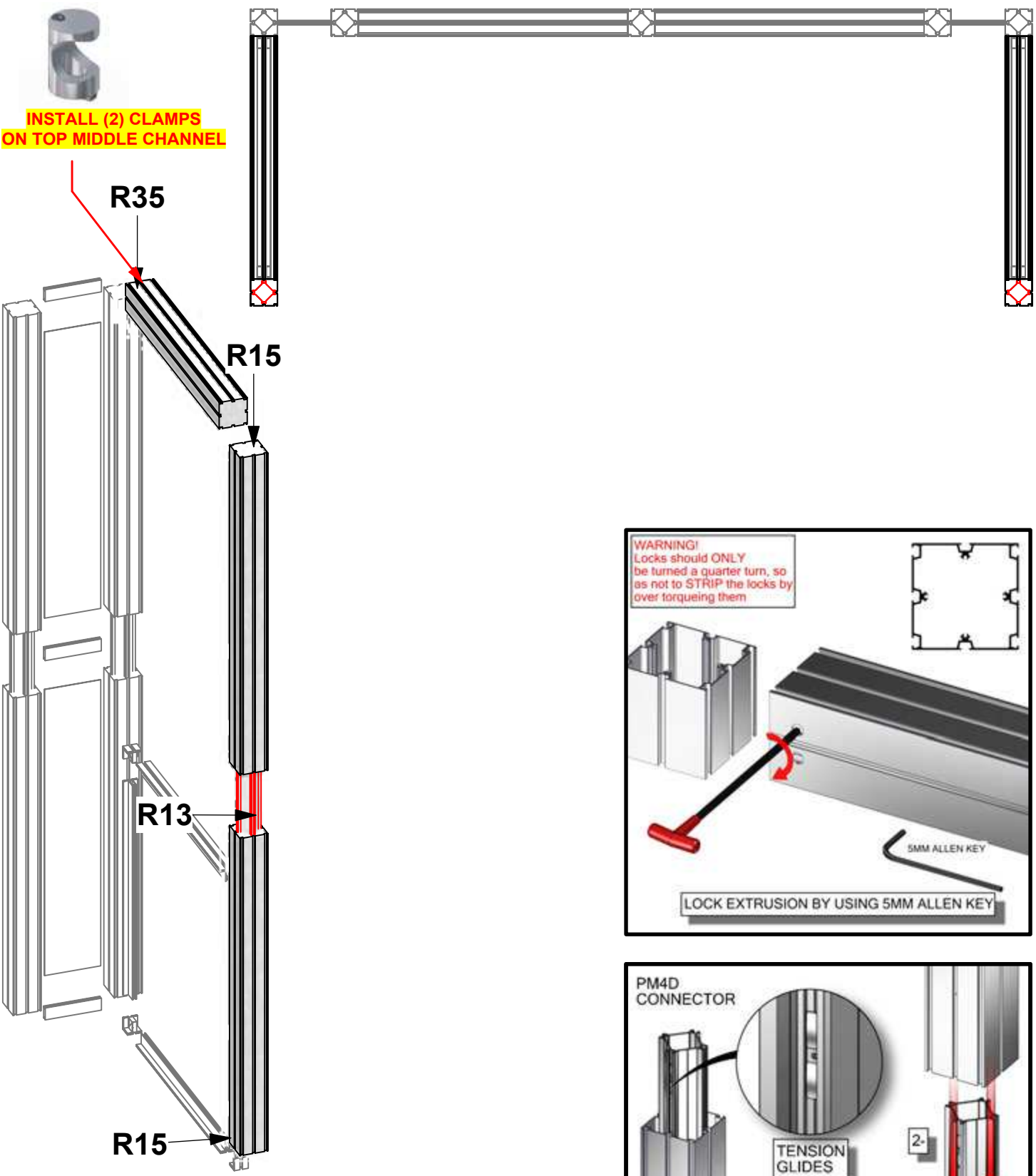
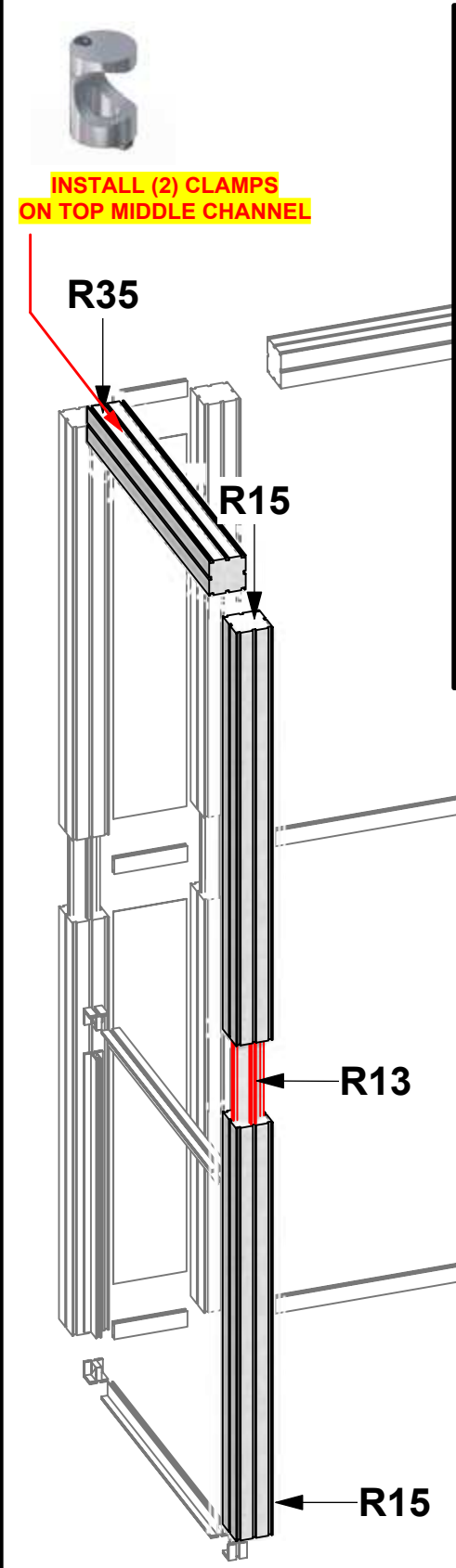

1. Redesign of this exhibit without approval by manufacturer may result in dangerous and unsafe structures. Manufacturer disclaims any responsibility for redesigned exhibits it does not approve in writing.

2. Parts and components such as panels and extrusions are manufactured to metric sizing. Where ever possible sizes have been noted in feet and inches as well as in metric. Below is the imperial to metric sizing table as reference. "Nominal" refers to approximate size.

2400mm = (94 1/2")	Phone Line / Fax
2100mm = (82 5/8")	Internet connection
1800mm = (70 7/8")	Outlet
1500mm = (59")	Main Drop (point of distrution)
1200mm = (47 1/4")	
900mm = (35 1/2")	
600mm = (23 5/8")	
300mm = (11 7/8")	

--- Wire running under carpet

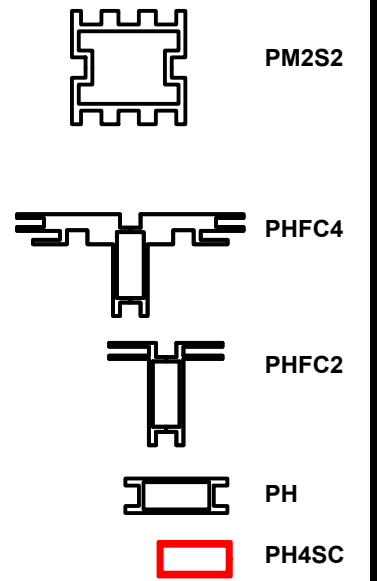

HYBRID PRO RENTAL KIT

Title: SET-UP INSTRUCTIONS

Code	#	Description
GRAPHIC A2	1	35.43"H X 35.43"W SINGLE SIDED DYESUB GRAPHIC W/FCE-2 ON PERIMETER
GRAPHIC A1	1	35.43"H X 35.43"W SINGLE SIDED DYESUB GRAPHIC W/FCE-2 ON PERIMETER
GRAPHIC A3	1	35.43"H X 35.43"W SINGLE SIDED DYESUB GRAPHIC W/FCE-2 ON PERIMETER
GRAPHIC A4	1	35.43"H X 35.43"W SINGLE SIDED DYESUB GRAPHIC W/FCE-2 ON PERIMETER

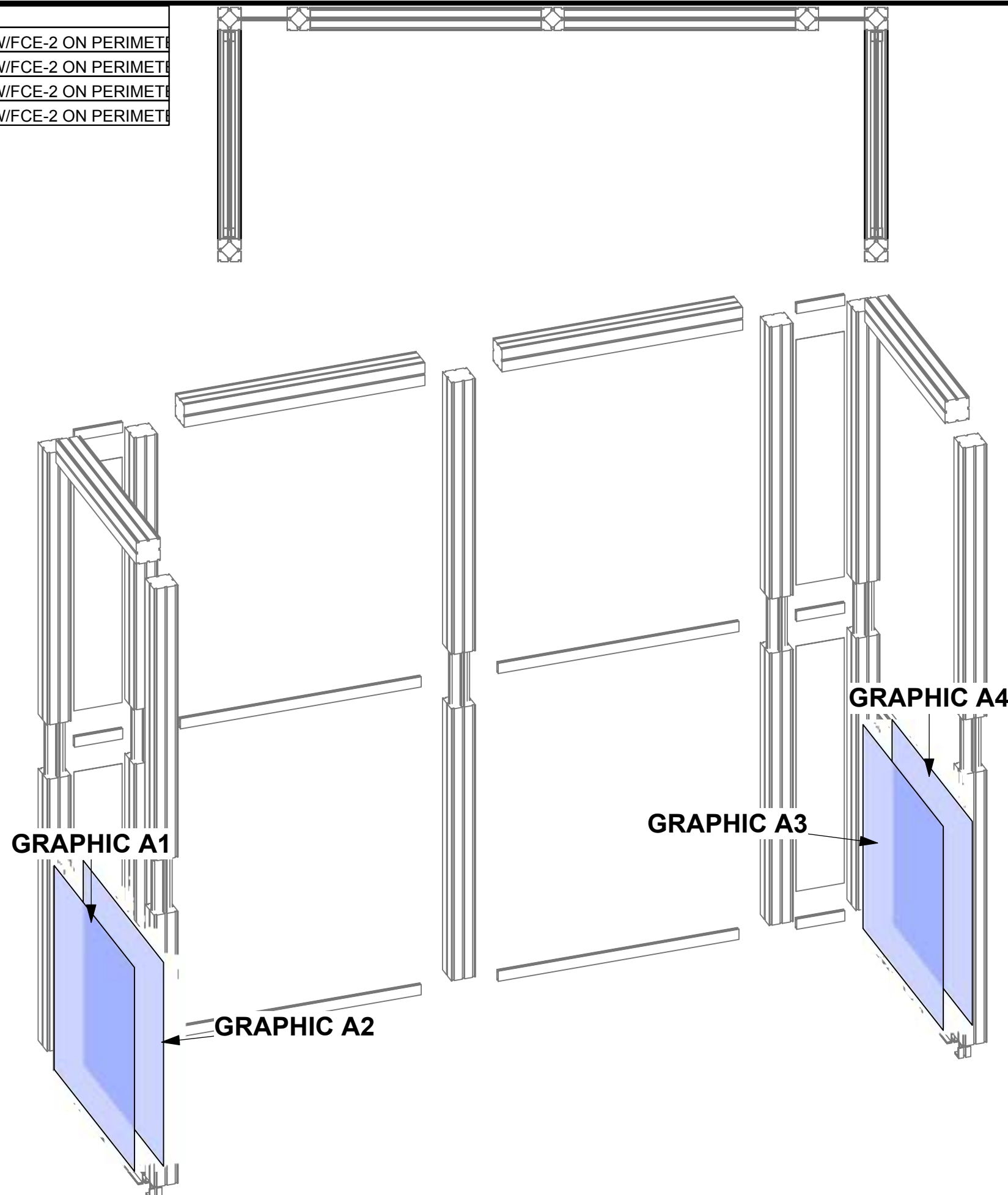
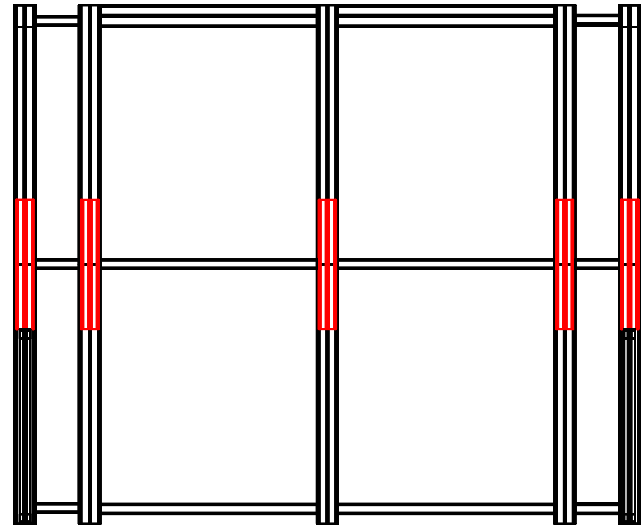

1. Redesign of this exhibit without approval by manufacturer may result in dangerous and unsafe structures. Manufacturer disclaims any responsibility for redesigned exhibits it does not approve in writing.

2. Parts and components such as panels and extrusions are manufactured to metric sizing. Where ever possible sizes have been noted in feet and inches as well as in metric. Below is the imperial to metric sizing table as reference. "Nominal" refers to approximate size.

- 2400mm = (94 1/2") Phone Line / Fax
 - 2100mm = (82 5/8") Internet connection
 - 1800mm = (70 7/8")
 - 1500mm = (59")
 - 1200mm = (47 1/4")
 - 900mm = (35 1/2")
 - 600mm = (23 5/8")
 - 300mm = (11 7/8")
- Outlet
- Main Drop (point of distrution)
- Wire running under carpet

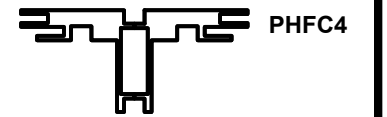
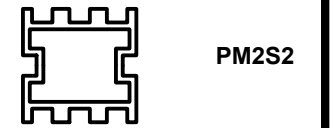

HYBRID PRO RENTAL KIT

Title: SET-UP INSTRUCTIONS

Code	#	Description
PM4 HINGE	3	90 DEG PM4 HINGE (POWDERCOATED 9006)
R36	3	300MM (11.81") 100MM PM4S2 SQUARE EXTRUSION WITH LOCKS 2 ENDS
R38	2	1155MM (45.47") PS2 EXTRUSION WITH LOCK 1 END - IB2 HOLE OTHER END
R33	2	1105MM (43.50") PS2 EXTRUSION WITH SLIDE LOCKS BOTH ENDS
IB2	6	PH INLINE CONNECTOR
R32	2	1105MM (43.50") PH EXTRUSION WITH SLIDE LOCKS 2 ENDS
CB9-S	4	50MM SQUARE PHCF2 CORNER BRACKET
R28	8	1155MM (45.47") PHFC2 EXTRUSION WITH IB2 HOLE ONE SIDE-WITH LOCK 1 END

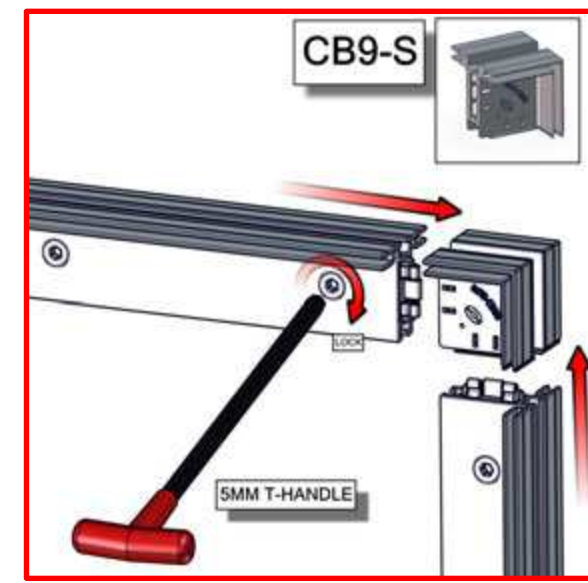
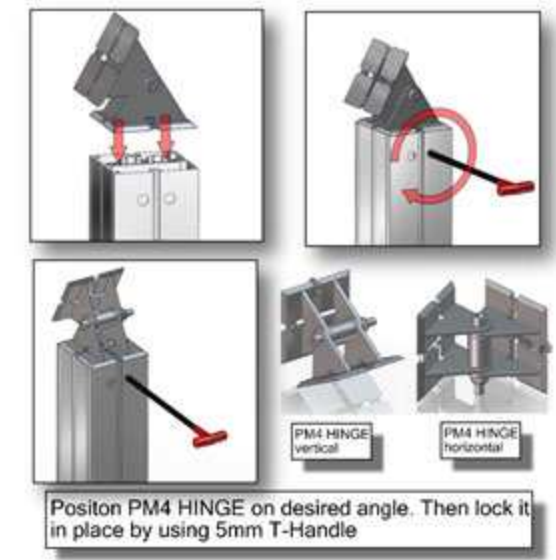
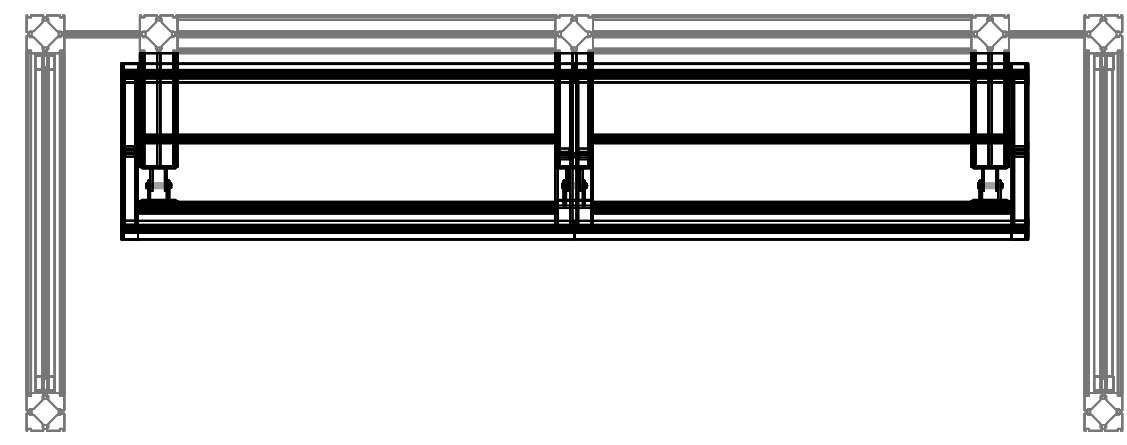
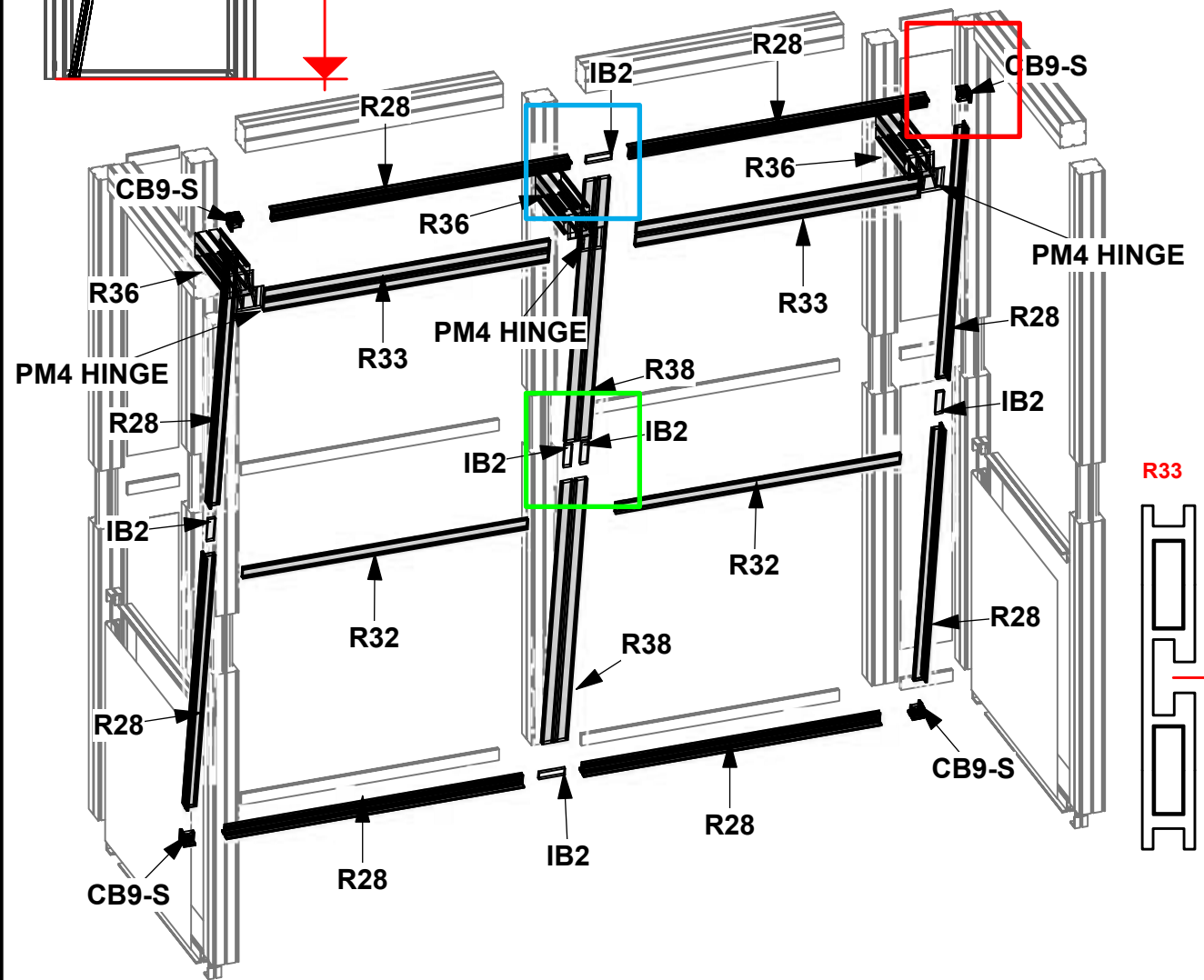
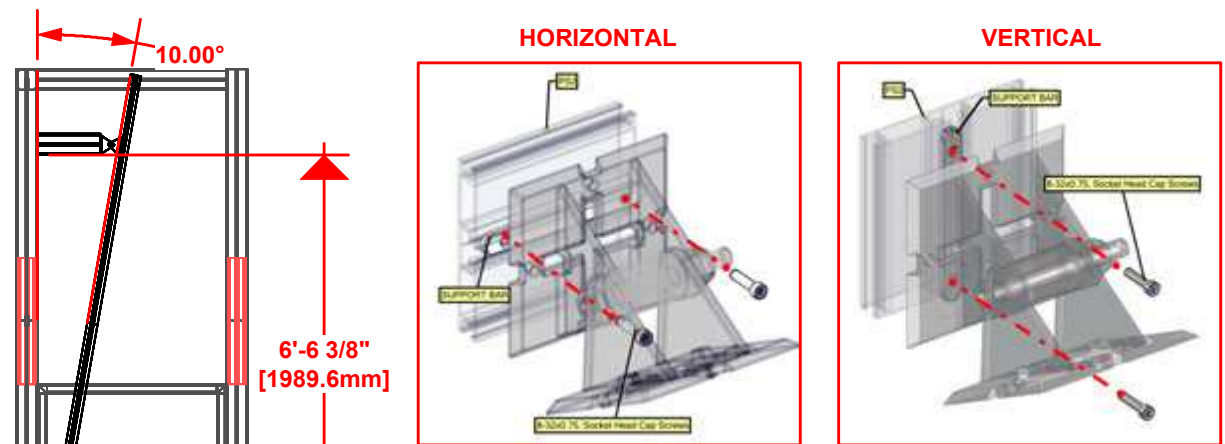

1. Redesign of this exhibit without approval by manufacturer may result in dangerous and unsafe structures. Manufacturer disclaims any responsibility for redesigned exhibits it does not approve in writing.

2. Parts and components such as panels and extrusions are manufactured to metric sizing. Where ever possible sizes have been noted in feet and inches as well as in metric. Below is the imperial to metric sizing table as reference. *Nominal refers to approximate size.

2400mm = (94 1/2")	Phone Line / Fax
2100mm = (82 5/8")	Internet connection
1800mm = (70 7/8")	Outlet
1500mm = (59")	Main Drop (point of distrution)
1200mm = (47 1/4")	
900mm = (35 1/2")	
600mm = (23 5/8")	
300mm = (11 7/8")	

--- Wire running under carpet

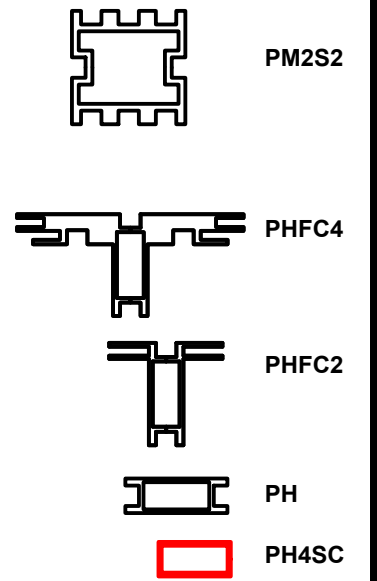

HYBRID PRO RENTAL KIT

Title: SET-UP INSTRUCTIONS

Code	#	Description
GRAPHIC C□□	1	94 1/2" (H) X 94 1/2" (W) SINGLE SIDED DYESUB GRAPHIC W/ FCE-2 (SE

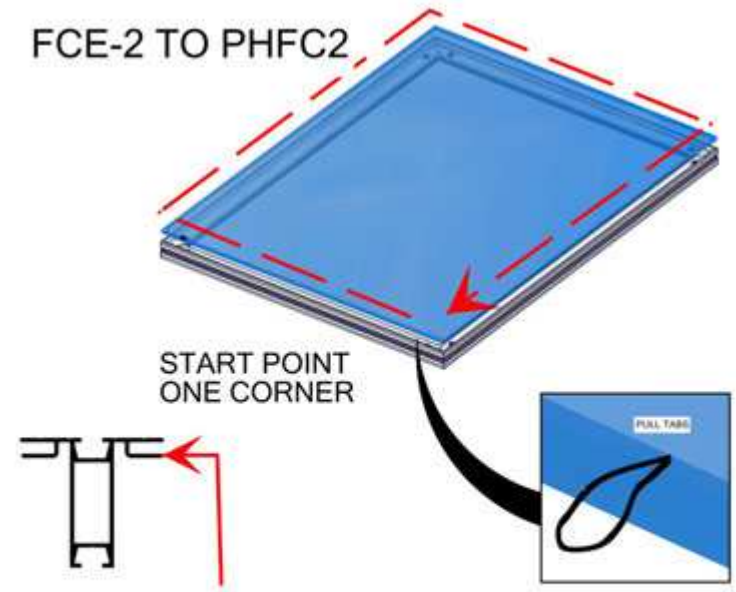
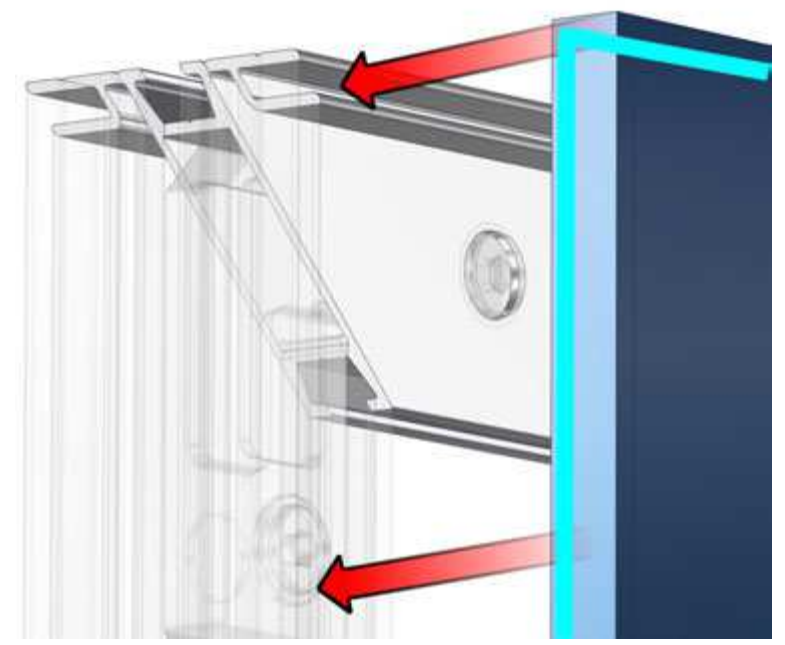
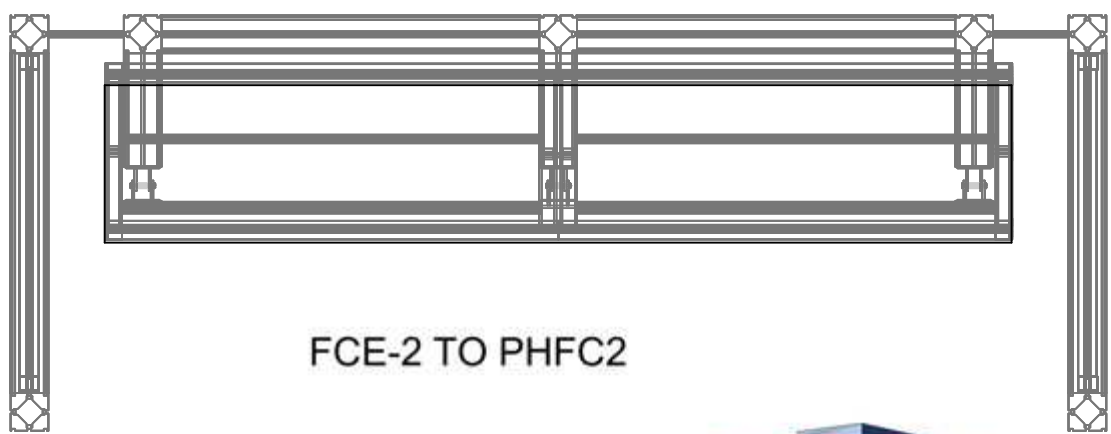
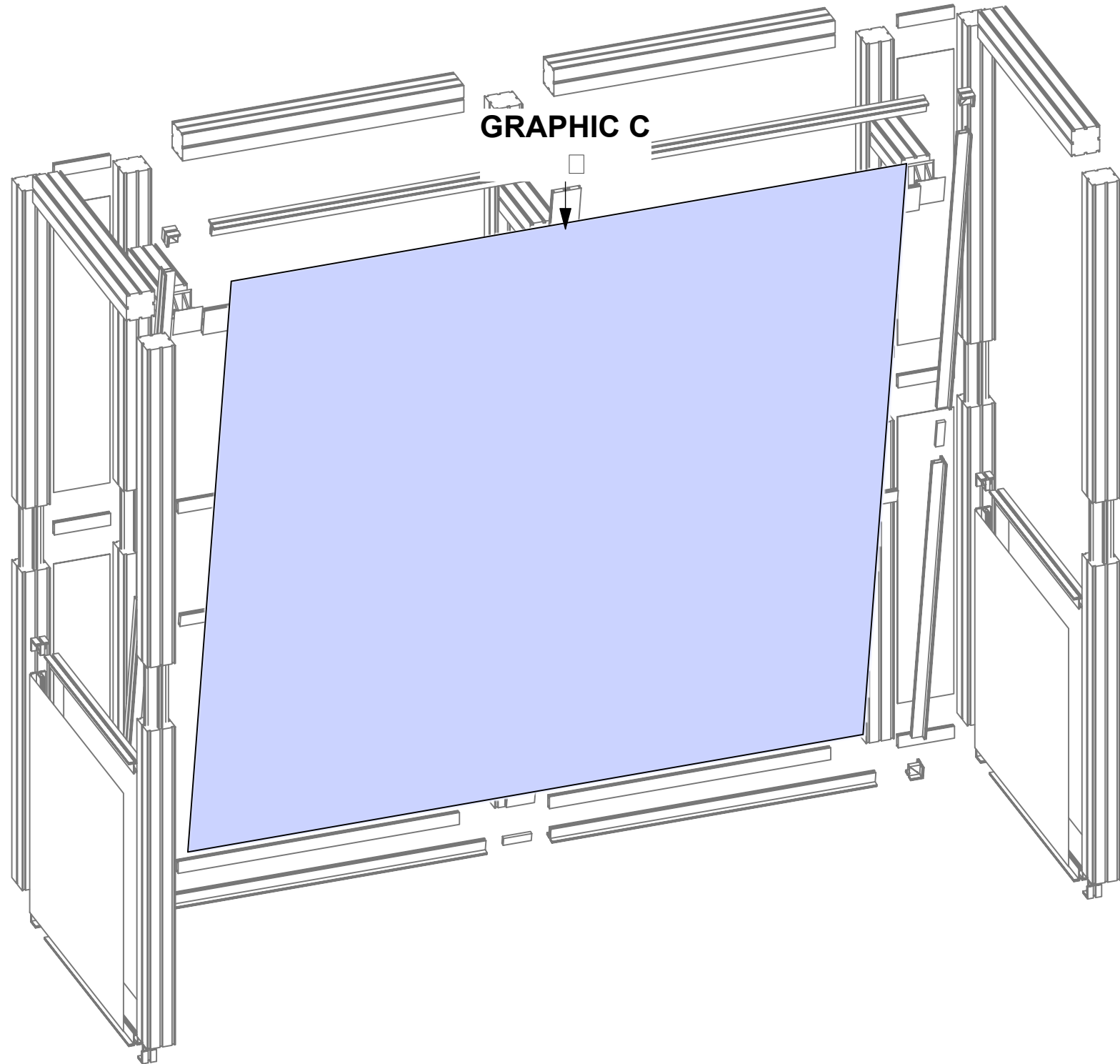

Install graphic by pressing the FCE-2 into the channels of PHFC2 extrusion. To pull graphics out of the channels, use tabs on the front side

1. Redesign of this exhibit without approval by manufacturer may result in dangerous and unsafe structures. Manufacturer disclaims any responsibility for redesigned exhibits it does not approve in writing.

2. Parts and components such as panels and extrusions are manufactured to metric sizing. Where ever possible sizes have been noted in feet and inches as well as in metric. Below is the imperial to metric sizing table as reference. "Nominal" refers to approximate size.

2400mm = (94 1/2")	☒ Phone Line / Fax
2100mm = (82 5/8")	☒ Internet connection
1800mm = (70 7/8")	☒ Outlet
1500mm = (59")	☒ Main Drop (point of distrution)
1200mm = (47 1/4")	
900mm = (35 1/2")	
600mm = (23 5/8")	
300mm = (11 7/8")	

--- Wire running under carpet

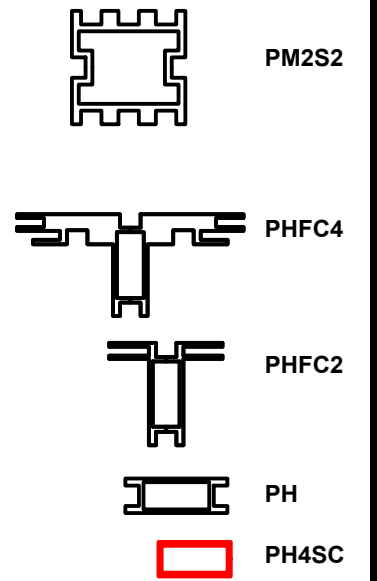

HYBRID PRO RENTAL KIT

Title: SET-UP INSTRUCTIONS

SET UP INSTRUCTIONS:

1. CONNECT BOTTOM AND TOP RAILS FOLLOWING THE LABELS
2. CONNECT SIDE RAILS
3. CLEAN THE FRAME AND PLACE THEM ON CLEAN PLACE
4. CAREFULLY REMOVE FABRIC COVER FROM BAGS
5. PLACE COVER AROUND THE BOTTOM OF THE FRAME
6. PULL COVER CAREFULLY UP TO THE TOP
7. CLOSE ALL ZIPPERS
8. ADJUST FABRIC AROUND THE FRAME

BREAK DOWN INSTRUCTIONS:

REVERSE SET-UP STEPS TO BREAKDOWN FRAME

FABRIC CARE INSTRUCTIONS:

1. UNZIP COVER ZIPPERS
2. CAREFULLY REMOVE FABRIC COVER
3. CLOSE ALL ZIPPERS
4. FOLD OR ROLL NEATLY
5. PLACE FABRIC IN COVER BAG

PART LIST:

- PER UNIT
- 7 30MM DIA. TUBE SECTIONS
 - 8 ES-30 EXPANDING SPIGOT
 - 1 2.5MM HEX KEY
 - 4 TCH-30
 - 1 FABRIC COVER

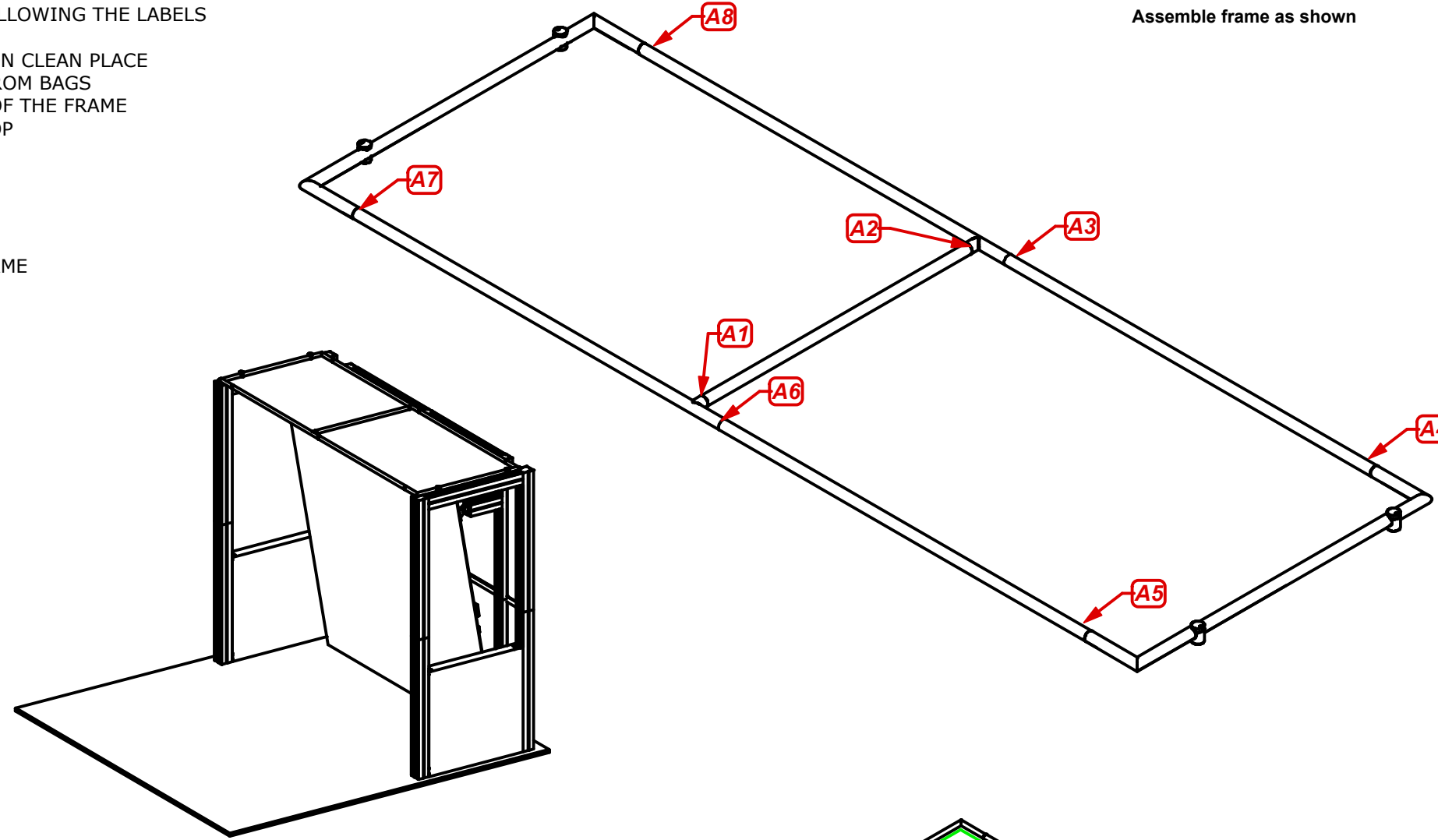

Frame 'A' Assembly

Assemble frame as shown

1. Redesign of this exhibit without approval by manufacturer may result in dangerous and unsafe structures. Manufacturer disclaims any responsibility for redesigned exhibits it does not approve in writing.

2. Parts and components such as panels and extrusions are manufactured to metric sizing. Where ever possible sizes have been noted in feet and inches as well as in metric. Below is the imperial to metric sizing table as reference. "Nominal" refers to approximate size.

2400mm = (94 1/2")	Phone Line / Fax
2100mm = (82 5/8")	Internet connection
1800mm = (70 7/8")	Outlet
1500mm = (59")	Main Drop (point of distrution)
1200mm = (47 1/4")	
900mm = (35 1/2")	
600mm = (23 5/8")	
300mm = (11 7/8")	

--- Wire running under carpet ---

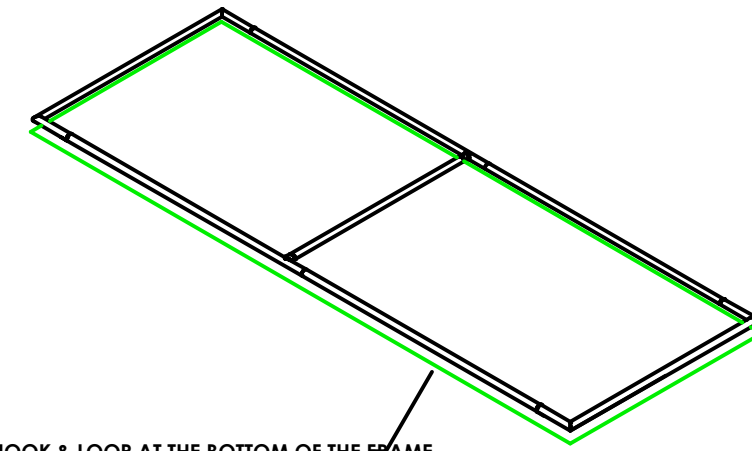
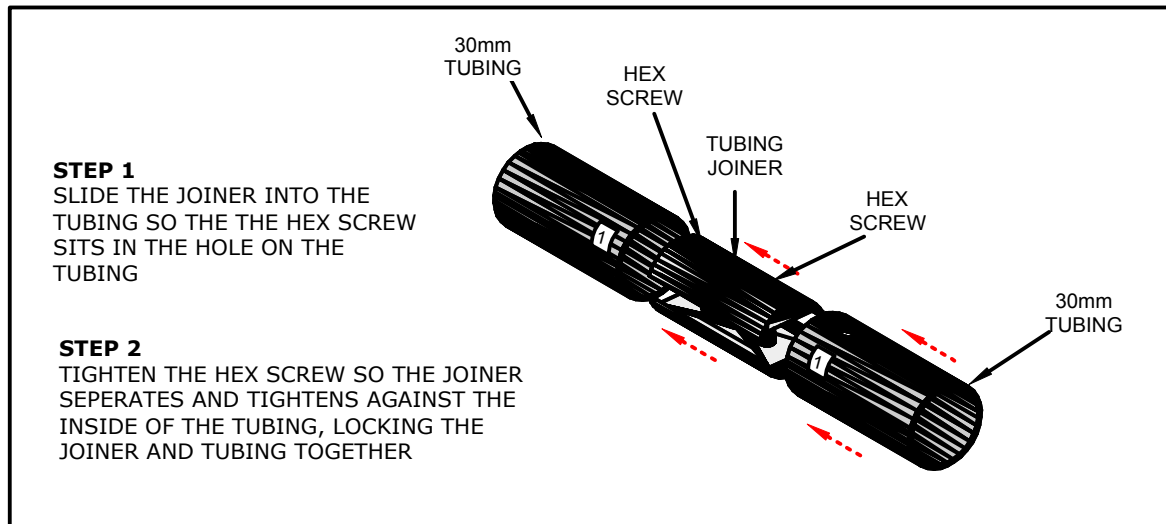
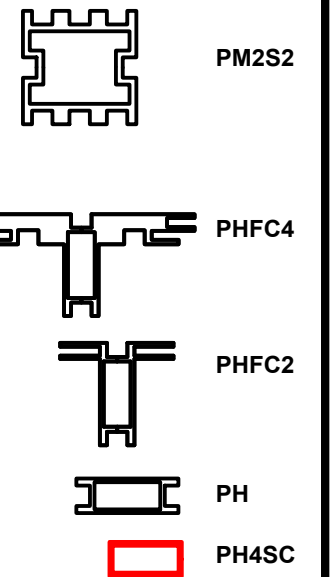

Fabric 'A' Assembly

HYBRID PRO RENTAL KIT

Title: SET-UP INSTRUCTIONS

Code	#	Description
GRAPHIC D	1	110 9/16" (H) X 39" (W) X 30MM TUBING - FABRIC STRUCTURE- ATTA

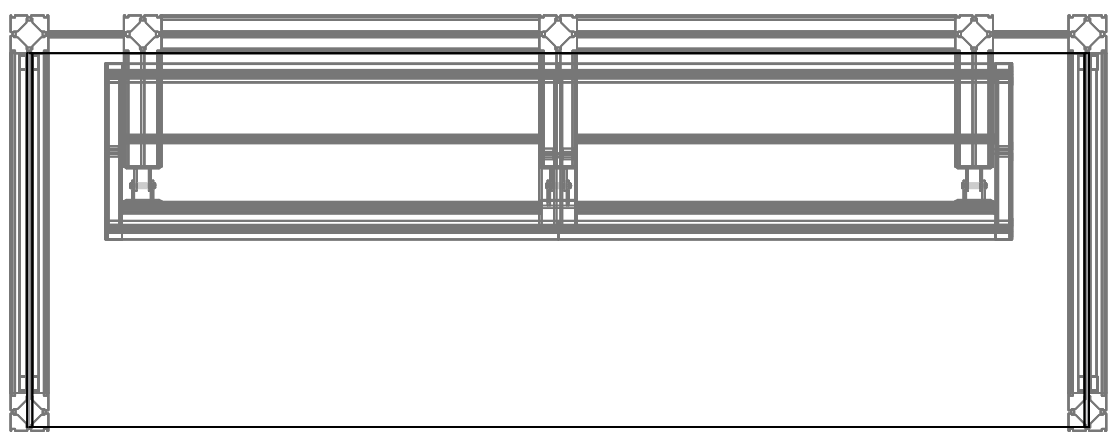



1. Redesign of this exhibit without approval by manufacturer may result in dangerous and unsafe structures. Manufacturer disclaims any responsibility for redesigned exhibits it does not approve in writing.

2. Parts and components such as panels and extrusions are manufactured to metric sizing. Where ever possible sizes have been noted in feet and inches as well as in metric. Below is the imperial to metric sizing table as reference. "Nominal" refers to approximate size.

- | | |
|--------------------|---------------------------------|
| 2400mm = (94 1/2") | Phone Line / Fax |
| 2100mm = (82 5/8") | Internet connection |
| 1800mm = (70 7/8") | Outlet |
| 1500mm = (59") | Main Drop (point of distrution) |
| 1200mm = (47 1/4") | |
| 900mm = (35 1/2") | |
| 600mm = (23 5/8") | |
| 300mm = (11 7/8") | |
- Wire running under carpet

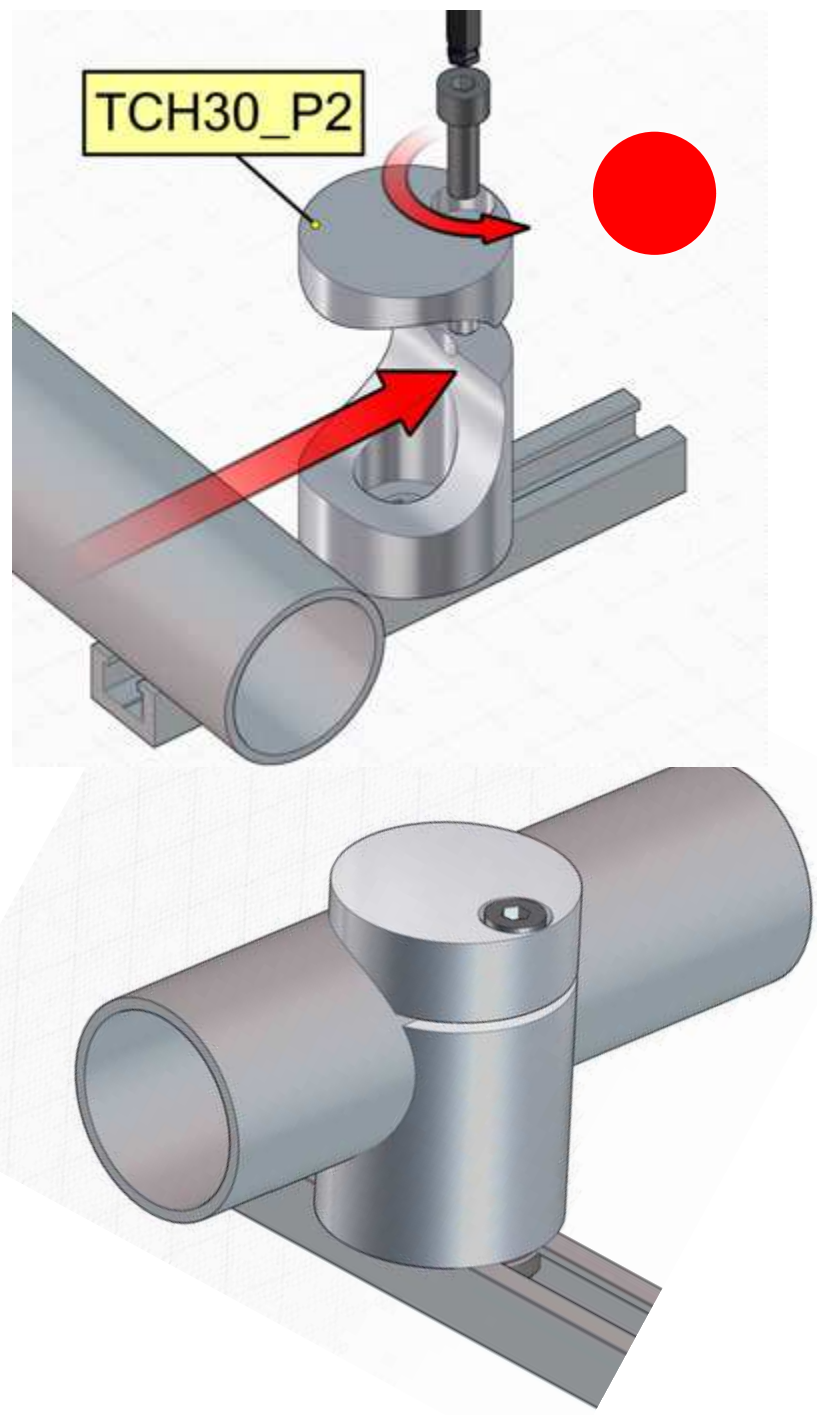
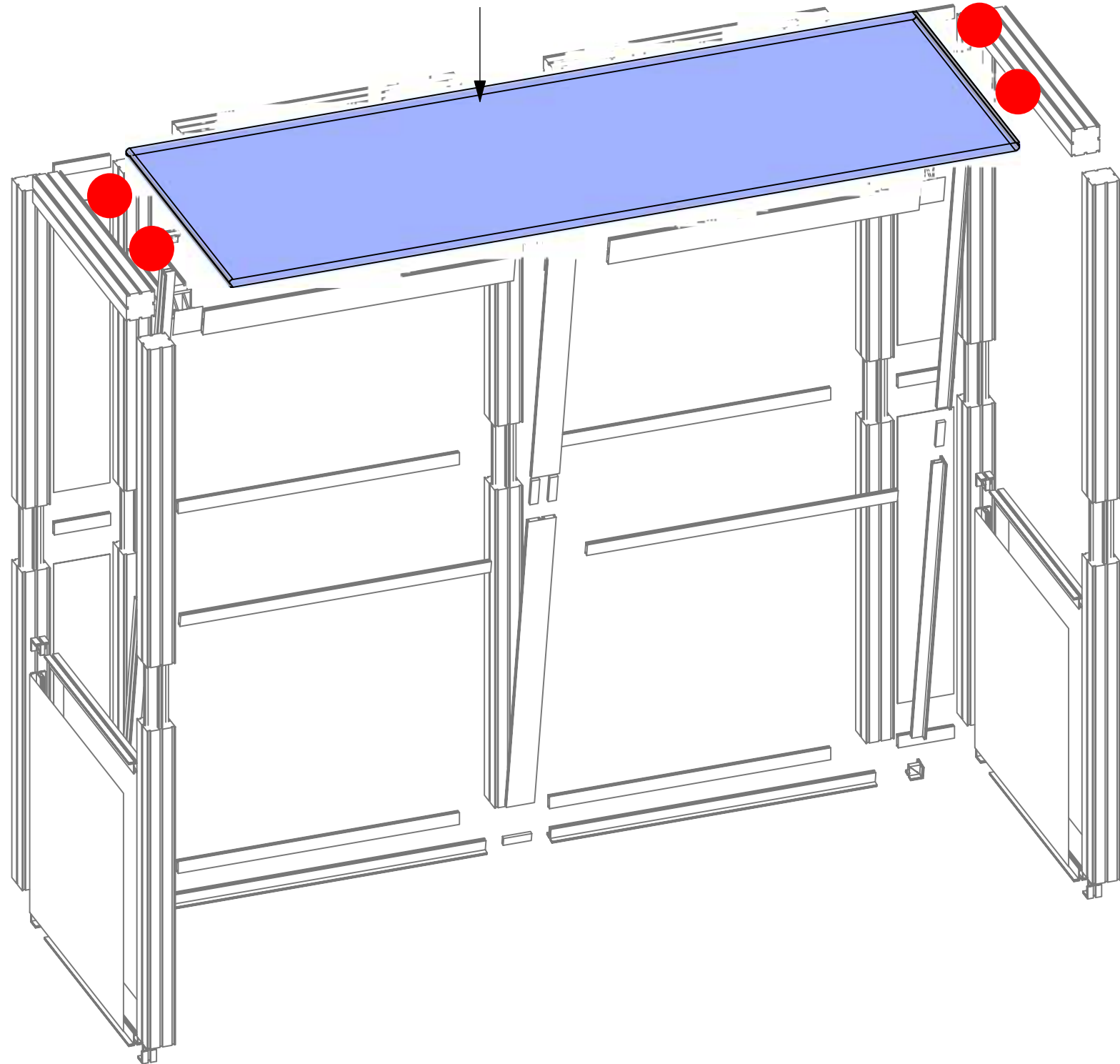
GRAPHIC D

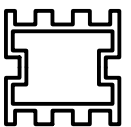
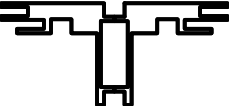
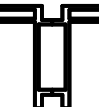

-  PM2S2
-  PHFC4
-  PHFC2
-  PH
-  PH4SC

HYBRID PRO RENTAL KIT

Title: SET-UP INSTRUCTIONS

PACKING INSTRUCTIONS



(1) STEAMER, (2) HARDWARE BOXES

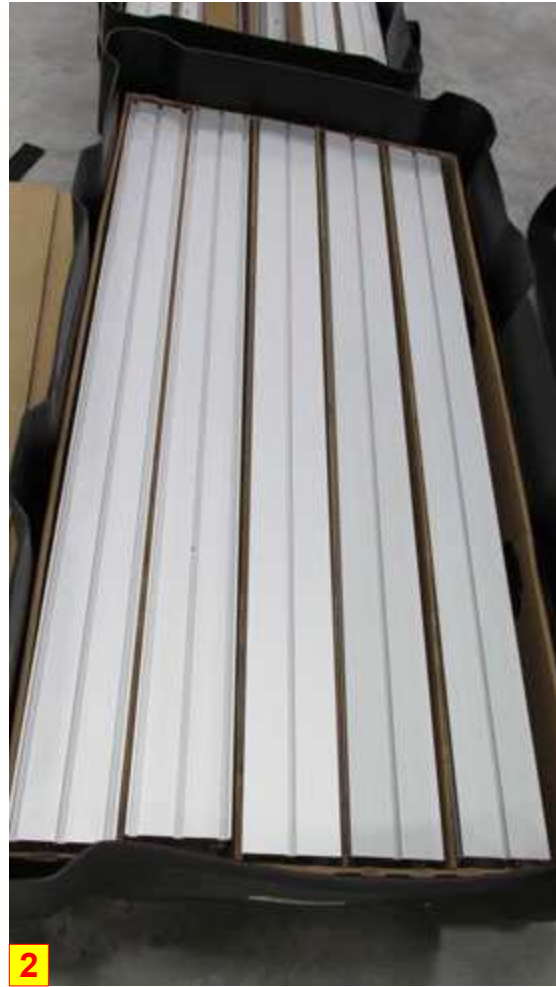

(5) R15



(2) R32, (4) R33, (4) R18, (8) R28



(4) R30, (4) R29



HARDWARE BOX



HARDWARE BOX

CASE # 1

LEGEND		GREY FOAM FOLDED TO FILL EMPTY SPACES OR USED AS PROTECTION
		1/8" CARDBOARD SPACER (PUT IN BETWEEN EVERY PANEL)
		DIVIDER
		1/4" WHITE FOAM (USED AS PROTECTION DOOR PANELS W/ LOCKS)





(2) R34, (3) R15



(4) R62, (5) R15







(1) R15, (2) R35, (3) R36, (3) R13



(1) STRUCTURE

CASE # 2

LEGEND		GREY FOAM FOLDED TO FILL EMPTY SPACES OR USED AS PROTECTION
		1/8" CARDBOARD SPACER (PUT IN BETWEEN EVERY PANEL)
		DIVIDER
		1/4" WHITE FOAM (USED AS PROTECTION DOOR PANELS W/ LOCKS)
	